



## Features

- High energy handling density
- Hybrid (MOV and GDT) design
- Extended temperature range
- Ring-wave tolerant
- Low capacitance
- UL recognized 
- RoHS compliant\*

IsoMOV™



## IsoMOV™ Series - Hybrid Protection Component

### General Information

Bourns introduces its hybrid technology that combines the breakthrough surge performance of EdgMOV™ protection devices with an integrated Gas Discharge Tube (GDT) isolation structure to create the innovative IsoMOV™ Series Hybrid Protection Component. By combining the best features of both MOV and GDT technologies into a single component, the IsoMOV™ Series achieves high performance as a long life protector with lower capacitance, very low leakage and superb energy handling density. The IsoMOV™ Series is ideally suited for AC and DC power applications where premium performance and/or space savings are required.

### Additional Information

Click these links for more information:



PRODUCT  
SELECTOR



TECHNICAL  
LIBRARY



INVENTORY



SAMPLES



CONTACT

### Agency Recognition

Agency	Standard	File Number
	1449 - 4th Ed. Type 4 CA Canadian Type 5 SPD CSA C22.2 No. 269.4-17	<a href="#">E313168</a>

### Electrical Characteristics <sup>(1)</sup> (@ T<sub>A</sub> = 25 °C Unless Otherwise Noted)

Bourns Part No.	Operating				Protection						
	Max. Continuous Operating Voltage (MCOV)		Maximum Leakage @ MCOV <sup>(2)</sup>	Nominal Capacitance	I <sub>nom</sub> <sup>(3) (4)</sup>		I <sub>max</sub> <sup>(4)</sup>	Energy <sup>(5)</sup>	Ring Wave Surge IEEE 62.41	Maximum Clamping Voltage	
	V <sub>rms</sub>	V <sub>dc</sub>	A <sub>dc</sub>	20 kHz	15 Operations	10 Operations	1 Operation	1 Operation	200 A	V <sub>c</sub>	I <sub>c</sub>
	V	V	μA	pF	A		A	J	Operations	V	A
IsoM3-175	175	225	< 10	30	3,000		6,000	88	± 250	470	50
IsoM3-230	230	300	< 10	30	3,000		6,000	109	± 250	620	50
IsoM3-250	250	320	< 10	30	3,000		6,000	117	± 250	675	50
IsoM3-275	275	350	< 10	30	3,000		6,000	126	± 250	730	50
IsoM3-300	300	385	< 10	30	3,000		6,000	136	± 250	800	50
IsoM3-320	320	415	< 10	30	3,000		6,000	144	± 250	875	50
IsoM5-175	175	225	< 10	40	5,000		10,000	144	± 250	470	100
IsoM5-230	230	300	< 10	40	5,000		10,000	188	± 250	620	100
IsoM5-250	250	320	< 10	40	5,000		10,000	203	± 250	675	100
IsoM5-275	275	350	< 10	40	5,000		10,000	223	± 250	730	100
IsoM5-300	300	385	< 10	40	5,000		10,000	242	± 250	800	100
IsoM5-320	320	415	< 10	40	5,000		10,000	258	± 250	875	100
IsoM5-380	385	505	< 10	40	5,000		10,000	305	± 250	1000	100
IsoM5-420	420	560	< 10	40	5,000		10,000	336	± 250	1100	100
IsoM5-510	510	670	< 10	40	5,000		10,000	407	± 250	1300	100
IsoM5-555	555	745	< 10	40	5,000		10,000	442	± 250	1400	100
IsoM8-250	250	320	< 10	50		8,000	15,000	313	± 250	675	200
IsoM8-275	275	350	< 10	50		8,000	15,000	340	± 250	730	200
IsoM8-300	300	385	< 10	50		8,000	15,000	367	± 250	800	200
IsoM8-320	320	415	< 10	50		8,000	15,000	388	± 250	875	200
IsoM8-380	385	505	< 10	50		8,000	15,000	453	± 250	1000	200
IsoM8-420	420	560	< 10	50		8,000	15,000	497	± 250	1100	200
IsoM8-510	510	670	< 10	50		8,000	15,000	594	± 250	1300	200
IsoM8-555	555	745	< 10	50		8,000	15,000	643	± 250	1400	200

(1) At delivery AQL 0.65 Level II, DIN ISO 2859.

(2) Maximum leakage limits after life ratings may exceed 10 μA, but will continue to protect at MCOV.

(3) I<sub>nom</sub> service life specified at 3-minute time intervals between surges with rated MCOV applied during the entire resting period and 15 minutes after the last surge.

(4) Surge profile 8/20 μs per IEC 61000-4-5.

(5) Measured at I<sub>max</sub>: 8/20 μs using numerical integration method  $E = \int_0^T P(t)dt$



**WARNING Cancer and Reproductive Harm**  
[www.P65Warnings.ca.gov](http://www.P65Warnings.ca.gov)

\*"IsoMOV" and "EdgMOV" are trademarks of Bourns, Inc.  
\*RoHS Directive 2015/863, Mar 31, 2015 and Annex.

Specifications are subject to change without notice. Users should verify actual device performance in their specific applications. The products described herein and this document are subject to specific legal disclaimers as set forth on the last page of this document, and at [www.bourns.com/docs/legal/disclaimer.pdf](http://www.bourns.com/docs/legal/disclaimer.pdf).

## Applications

### AC Line Protection

- White goods
- Fire alarm systems
- High value consumer goods
- LED lighting
- UL1449 SPD
- Industrial equipment

### DC Line Protection

- Solar inverters
- Power supplies
- Distribution systems

## IsoMOV™ Series - Hybrid Protection Component

## BOURNS®

### Environmental Specifications

Storage Temperature Range ( $T_{STG}$ ) ..... -40 °C to +125 °C  
 Operating Temperature Range ( $T_{OPR}$ ) ..... -40 °C to +125 °C  
 Climatic Category (IEC 60068-1) ..... 40 / 125 / 21  
 Moisture Sensitivity Level ..... 1  
 ESD Classification (HBM) ..... N/A

### How to Order

**IsoM 8 - 320 - B - L2**

Model Designator \_\_\_\_\_  
 IsoM = IsoMOV™ Hybrid Protection Component

Component  $I_{nom}$  Rating \_\_\_\_\_  
 3 = 3 kA  
 5 = 5 kA  
 8 = 8 kA

RMS Voltage \_\_\_\_\_  
 See Electrical Characteristics Table

Packaging \_\_\_\_\_  
 B = Bulk (Standard)  
 R = Reel Pack\*

Lead Style \_\_\_\_\_  
 L1 = Straight Leads  
 L2 = In-Line Leads (Standard)  
 L5 = Crimped Leads

\*Reel Pack option not available for IsoM8 models.

### Circuit Diagram

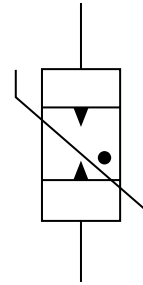

### Typical Part Marking

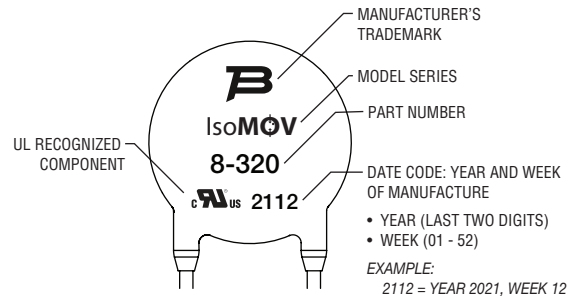

### Assembly Recommendations for Through-Hole Components

#### Lead-free Wave Soldering Profile - Pb-free wave profile requirements for soldering heat resistance of components

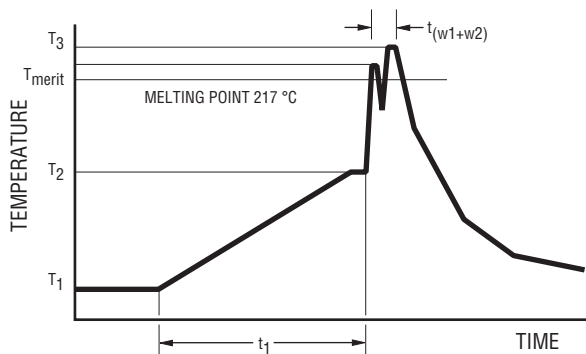

Parameter	Symbol	Specification
Preheating temperature gradient		4 °C/sec. max.
Preheating time	$t_1$	2 to 5 min.
Min. preheating temperature	$T_1$	130 °C
Max. preheating temperature	$T_2$	180 °C
Melting temperature/point	$T_{meltv}$	217 °C
Time in wave soldering phase ( $w_1+w_2$ )	$t_{w1+w2}$	10 sec.
Max. wave temperature ( $w_1+w_2$ )	$T_s$	265 °C +0/-5 °C
Cooling temperature gradient		6° C/sec. max.
Temperature jump from $T_2$ to $T_3$ ( $w_1$ )	$T_{3(w1)} - T_2$	120 °C max
Time from 25 °C to $T_3$ (wave temperature)		8 min. max.

Specifications are subject to change without notice.

Users should verify actual device performance in their specific applications.

The products described herein and this document are subject to specific legal disclaimers as set forth on the last page of this document, and at [www.bourns.com/docs/legal/disclaimer.pdf](http://www.bourns.com/docs/legal/disclaimer.pdf).

## IsoMOV™ Series - Hybrid Protection Component

## BOURNS®

### Product Dimensions

**IsoM3-xxx-L1  
Straight Leads**

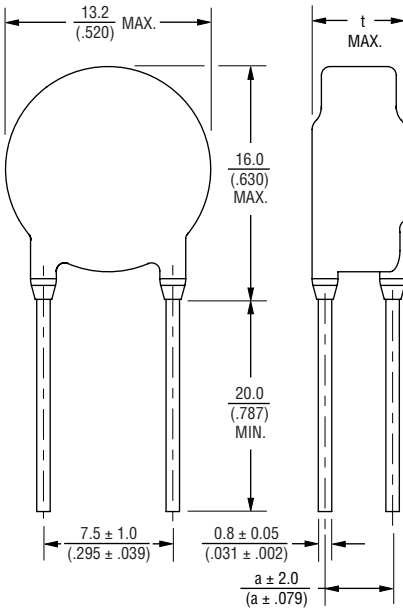

**IsoM3-xxx-L2  
In-Line Leads**

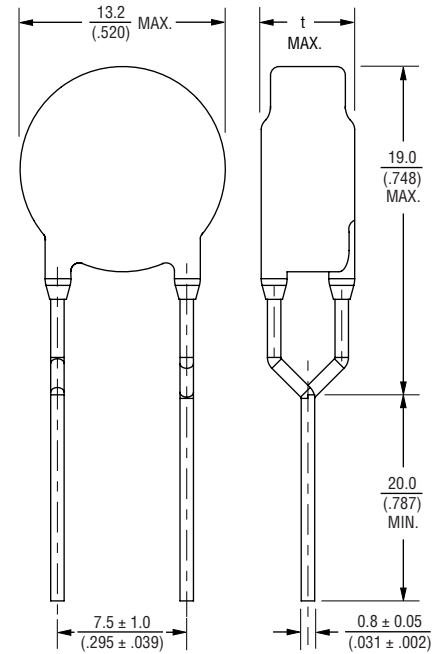

**IsoM3-xxx-L5  
Crimped Leads**

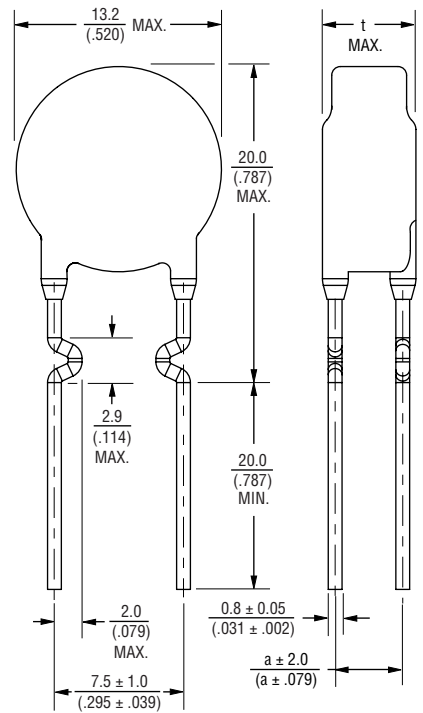

Model	IsoM3-xxx-L1		IsoM3-xxx-L2		IsoM3-xxx-L5	
	a	t	a	t	a	t
IsoM3-175	$\frac{2.8}{(.110)}$	$\frac{6.1}{(.240)}$	--	$\frac{6.1}{(.240)}$	$\frac{2.8}{(.110)}$	$\frac{6.1}{(.240)}$
IsoM3-230	$\frac{3.3}{(.129)}$	$\frac{6.5}{(.256)}$	--	$\frac{6.5}{(.256)}$	$\frac{3.3}{(.129)}$	$\frac{6.5}{(.256)}$
IsoM3-250	$\frac{3.5}{(.137)}$	$\frac{6.7}{(.264)}$	--	$\frac{6.7}{(.264)}$	$\frac{3.5}{(.137)}$	$\frac{6.7}{(.264)}$
IsoM3-275	$\frac{3.6}{(.141)}$	$\frac{6.9}{(.272)}$	--	$\frac{6.9}{(.272)}$	$\frac{3.6}{(.141)}$	$\frac{6.9}{(.272)}$
IsoM3-300	$\frac{3.9}{(.153)}$	$\frac{7.1}{(.280)}$	--	$\frac{7.1}{(.280)}$	$\frac{3.9}{(.153)}$	$\frac{7.1}{(.280)}$
IsoM3-320	$\frac{4.0}{(.157)}$	$\frac{7.2}{(.283)}$	--	$\frac{7.2}{(.283)}$	$\frac{4.0}{(.157)}$	$\frac{7.2}{(.283)}$

DIMENSIONS:  $\frac{\text{MM}}{\text{(INCHES)}}$

Specifications are subject to change without notice.

Users should verify actual device performance in their specific applications.

The products described herein and this document are subject to specific legal disclaimers as set forth on the last page of this document, and at [www.bourns.com/docs/legal/disclaimer.pdf](http://www.bourns.com/docs/legal/disclaimer.pdf).

## IsoMOV™ Series - Hybrid Protection Component

# BOURNS®

### Product Dimensions (Continued)

**IsoM5-xxx-L1  
Straight Leads**

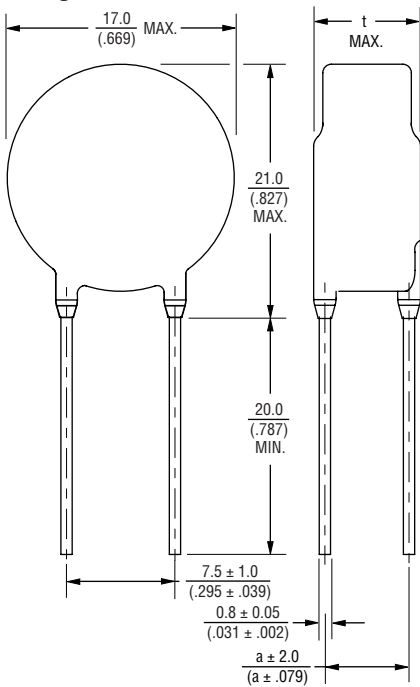

**IsoM5-xxx-L2  
In-Line Leads**

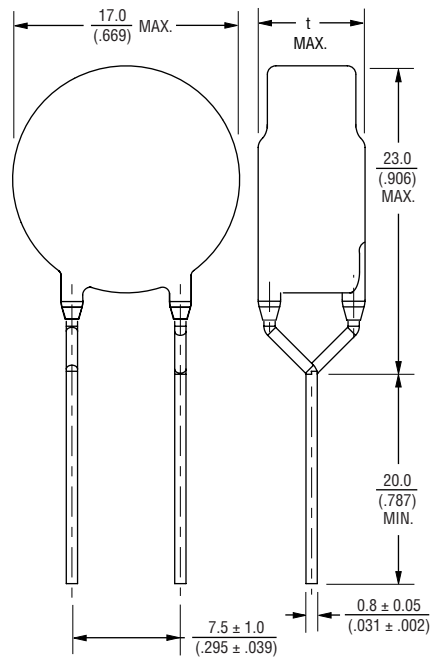

**IsoM5-xxx-L5  
Crimped Leads**

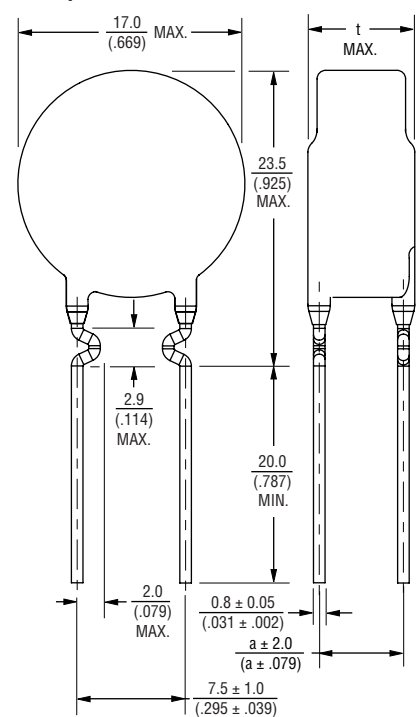

Model	IsoM5-xxx-L1		IsoM5-xxx-L2		IsoM5-xxx-L5	
	a	t	a	t	a	t
IsoM5-175	$\frac{2.8}{(.110)}$	$\frac{6.0}{(.236)}$	--	$\frac{6.0}{(.236)}$	$\frac{2.8}{(.110)}$	$\frac{6.0}{(.236)}$
IsoM5-230	$\frac{3.3}{(.130)}$	$\frac{6.5}{(.256)}$	--	$\frac{6.5}{(.256)}$	$\frac{3.3}{(.130)}$	$\frac{6.5}{(.256)}$
IsoM5-250	$\frac{3.5}{(.138)}$	$\frac{6.7}{(.264)}$	--	$\frac{6.7}{(.264)}$	$\frac{3.5}{(.138)}$	$\frac{6.7}{(.264)}$
IsoM5-275	$\frac{3.6}{(.142)}$	$\frac{6.8}{(.268)}$	--	$\frac{6.8}{(.268)}$	$\frac{3.6}{(.142)}$	$\frac{6.8}{(.268)}$
IsoM5-300	$\frac{3.9}{(.154)}$	$\frac{7.1}{(.280)}$	--	$\frac{7.1}{(.280)}$	$\frac{3.9}{(.154)}$	$\frac{7.1}{(.280)}$
IsoM5-320	$\frac{3.9}{(.154)}$	$\frac{7.1}{(.280)}$	--	$\frac{7.1}{(.280)}$	$\frac{3.9}{(.154)}$	$\frac{7.1}{(.280)}$
IsoM5-380	$\frac{4.5}{(.177)}$	$\frac{7.7}{(.303)}$	--	$\frac{7.7}{(.303)}$	$\frac{4.5}{(.177)}$	$\frac{7.7}{(.303)}$
IsoM5-420	$\frac{4.9}{(.193)}$	$\frac{8.1}{(.319)}$	--	$\frac{8.1}{(.319)}$	$\frac{4.9}{(.193)}$	$\frac{8.1}{(.319)}$
IsoM5-510	$\frac{5.6}{(.220)}$	$\frac{8.8}{(.346)}$	--	$\frac{8.8}{(.346)}$	$\frac{5.6}{(.220)}$	$\frac{8.8}{(.346)}$
IsoM5-555	$\frac{5.8}{(.228)}$	$\frac{9.0}{(.354)}$	--	$\frac{9.0}{(.354)}$	$\frac{5.8}{(.228)}$	$\frac{9.0}{(.354)}$

DIMENSIONS:  $\frac{\text{MM}}{\text{(INCHES)}}$

Specifications are subject to change without notice.

Users should verify actual device performance in their specific applications.

The products described herein and this document are subject to specific legal disclaimers as set forth on the last page of this document, and at [www.bourns.com/docs/legal/disclaimer.pdf](http://www.bourns.com/docs/legal/disclaimer.pdf).

## IsoMOV™ Series - Hybrid Protection Component

## BOURNS®

### Product Dimensions (Continued)

**IsoM8-xxx-L1**  
Straight Leads

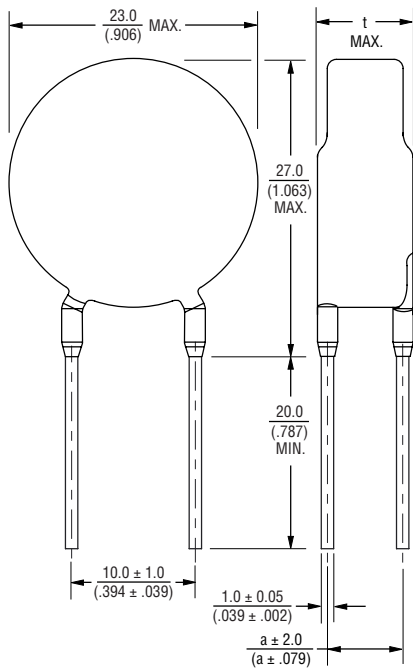

**IsoM8-xxx-L2**  
In-Line Leads

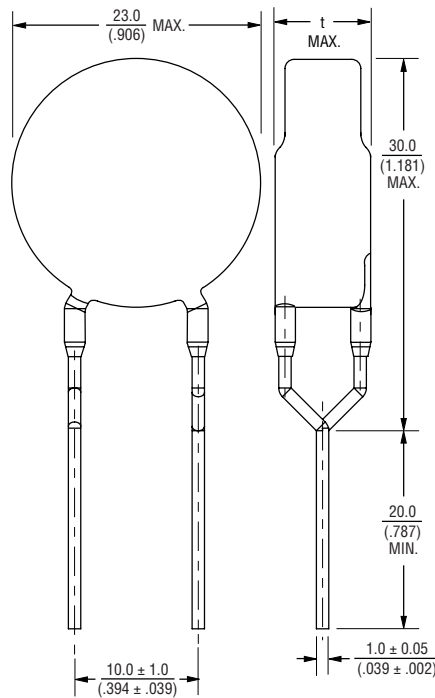

**IsoM8-xxx-L5**  
Crimped Leads

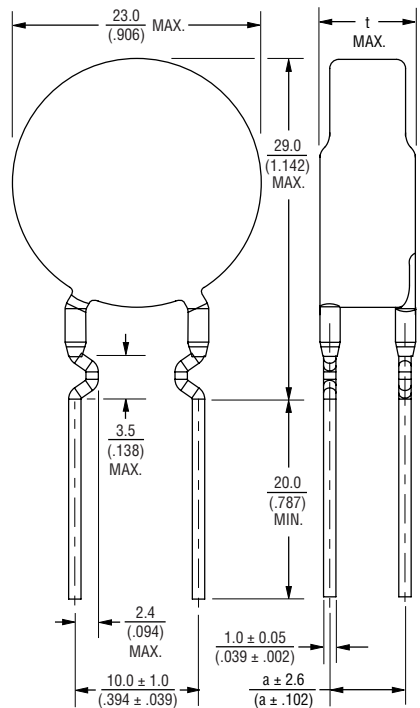

Model	IsoM8-xxx-L1		IsoM8-xxx-L2		IsoM8-xxx-L5	
	a	t	a	t	a	t
IsoM8-250	$\frac{3.7}{(.146)}$	$\frac{7.1}{(.280)}$	--	$\frac{7.1}{(.280)}$	$\frac{3.7}{(.146)}$	$\frac{7.1}{(.280)}$
IsoM8-275	$\frac{3.8}{(.150)}$	$\frac{7.2}{(.283)}$	--	$\frac{7.2}{(.283)}$	$\frac{3.8}{(.150)}$	$\frac{7.2}{(.283)}$
IsoM8-300	$\frac{4.1}{(.161)}$	$\frac{7.5}{(.295)}$	--	$\frac{7.5}{(.295)}$	$\frac{4.1}{(.161)}$	$\frac{7.5}{(.295)}$
IsoM8-320	$\frac{4.2}{(.165)}$	$\frac{7.6}{(.299)}$	--	$\frac{7.6}{(.299)}$	$\frac{4.2}{(.165)}$	$\frac{7.6}{(.299)}$
IsoM8-380	$\frac{4.6}{(.181)}$	$\frac{8.0}{(.315)}$	--	$\frac{8.0}{(.315)}$	$\frac{4.6}{(.181)}$	$\frac{8.0}{(.315)}$
IsoM8-420	$\frac{5.0}{(.197)}$	$\frac{8.4}{(.331)}$	--	$\frac{8.4}{(.331)}$	$\frac{5.0}{(.197)}$	$\frac{8.4}{(.331)}$
IsoM8-510	$\frac{5.8}{(.228)}$	$\frac{9.2}{(.362)}$	--	$\frac{9.2}{(.362)}$	$\frac{5.8}{(.228)}$	$\frac{9.2}{(.362)}$
IsoM8-555	$\frac{6.0}{(.236)}$	$\frac{9.4}{(.370)}$	--	$\frac{9.4}{(.370)}$	$\frac{6.0}{(.236)}$	$\frac{9.4}{(.370)}$

DIMENSIONS:  $\frac{\text{MM}}{\text{(INCHES)}}$

Specifications are subject to change without notice.

Users should verify actual device performance in their specific applications.

The products described herein and this document are subject to specific legal disclaimers as set forth on the last page of this document, and at [www.bourns.com/docs/legal/disclaimer.pdf](http://www.bourns.com/docs/legal/disclaimer.pdf).

## IsoMOV™ Series - Hybrid Protection Component

# BOURNS®

### Packaging Specifications

#### TAPE

Conforms to IEC 60286-2:2015.

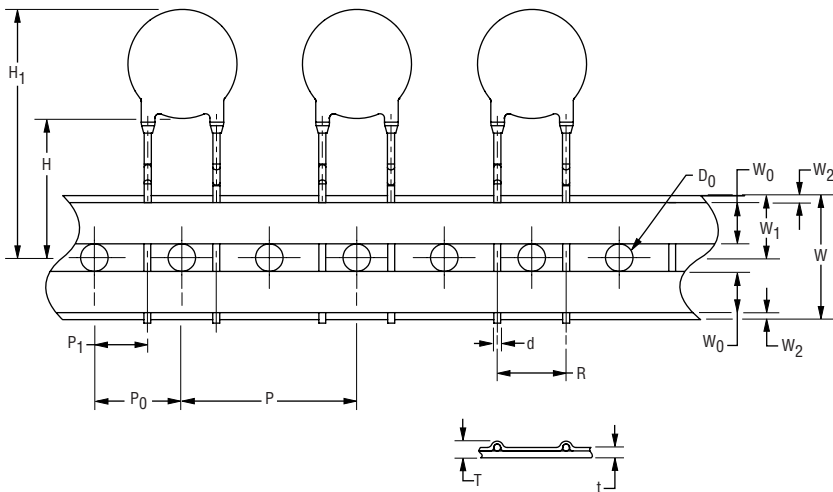
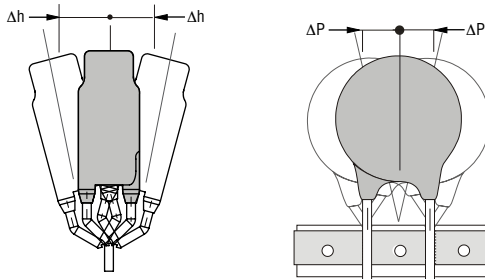

Symbol	Parameter	Dimension
W	Carrier tape width	$\frac{18 + 1.0/-0.5}{(.709 + .039/-0.020)}$
W <sub>0</sub>	Hold down tape width	$\frac{5}{(.197)}$ MIN.
W <sub>1</sub>	Sprocket hole position	$\frac{9 + 0.75/-0.5}{(.354 + .030/-0.020)}$
W <sub>2</sub>	Distance between the upper edges of the carrier tape and hold down tape	$\frac{3}{(.118)}$ MAX.
T	Total tape thickness	$\frac{1.7}{(.067)}$ MAX.
t	Tape thickness	$\frac{0.9}{(.035)}$ MAX.
P	Pitch of component	$\frac{25.4 \pm 1.0}{(1.000 \pm .039)}$
P <sub>0</sub>	Feed hole pitch	$\frac{12.7 \pm 0.3}{(.500 \pm .012)}$
P <sub>1</sub>	Feed hole center to pitch	$\frac{8.95 \pm 0.7}{(.352 \pm .028)}$
R	Lead spacing	$\frac{7.5 \pm 1.0}{(.295 + .039)}$
ΔP	Component alignment	$\frac{\pm 1.3}{(\pm .051)}$ MAX.
Δh	Component alignment	$\frac{\pm 2.0}{(\pm .079)}$ MAX.
d	Wire diameter	$\frac{0.8 \pm 0.05}{(.031 \pm .002)}$
D <sub>0</sub>	Feed hole diameter	$\frac{4 \pm 0.2}{(.157 \pm .008)}$
H	Height from tape center to component base	$\frac{18 + 2.0/-0.0}{(.709 + .079/-0.000)}$
H <sub>1</sub>	Component height	$\frac{46.5}{(1.831)}$ MAX.

DIMENSIONS:  $\frac{\text{MM}}{\text{(INCHES)}}$

#### REEL

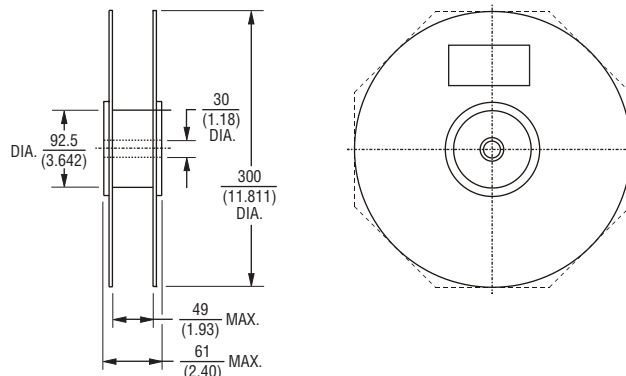

DIMENSIONS:  $\frac{\text{MM}}{\text{(INCHES)}}$

Specifications are subject to change without notice.

Users should verify actual device performance in their specific applications.

The products described herein and this document are subject to specific legal disclaimers as set forth on the last page of this document, and at [www.bourns.com/docs/legal/disclaimer.pdf](http://www.bourns.com/docs/legal/disclaimer.pdf).

## IsoMOV™ Series - Hybrid Protection Component

## BOURNS®

### Packaging Quantities - Bulk

Voltage	Model			
	IsoM3	IsoM5	IsoM8	
175	500	300		
230				
250				
275				
300				
320				
380				200
420				
510				
555				

### Packaging Quantities - Reel

Voltage	Model		
	IsoM3	IsoM5	IsoM8
175	500	400	
230			
250			
275	400		
300			
320			
380		300	
420			
510			
555			

## BOURNS®

**Asia-Pacific:** Tel: +886-2 2562-4117 • Email: [asiacus@bourns.com](mailto:asiacus@bourns.com)

**EMEA:** Tel: +36 88 885 877 • Email: [eurocus@bourns.com](mailto:eurocus@bourns.com)

**The Americas:** Tel: +1-951 781-5500 • Email: [americus@bourns.com](mailto:americus@bourns.com)

[www.bourns.com](http://www.bourns.com)

REV. G - 08/23

Specifications are subject to change without notice.

Users should verify actual device performance in their specific applications.

The products described herein and this document are subject to specific legal disclaimers as set forth on the last page of this document, and at [www.bourns.com/docs/legal/disclaimer.pdf](http://www.bourns.com/docs/legal/disclaimer.pdf).