

ION[®] 500 and 3000 Digital Drives



ION 500 and 3000 Digital Drives are compact, fully enclosed modules that provide high performance motion control, network connectivity and power amplification. Two power output levels are available, the ION 500 is rated at 500 Watts and the ION 3000 is rated at 3,000 Watts. All IONs can drive DC Brush, Brushless DC and step motors, and are ideal for medical, scientific, semiconductor, robotic, industrial and other automation applications.

Powerful Features

IONs provide high power density in a rugged, flexible form factor. They perform profile generation, servo compensation, stall detection, field oriented control, digital torque control and many other motion control functions. Additional features include Ethernet, CANbus or serial communications, general purpose digital and analog I/Os, and full programmability for the ION 500 CME.

Easy To Use and Program

Working with the ION Digital Drive, PMD's powerful Pro-Motion[®] GUI makes it easy to graph and analyze axis performance, while C-Motion[®] allows users to develop their own applications using C/C++. Programmable versions (ION/CME) include PMD's C-Motion of the ION Drives Engine, allowing users to directly run code on the ION, off-loading the system host and enabling standalone operation.

Built on the Magellan[®] Motion Control IC

ION's Magellan Motion provides a powerful instruction set to control the motion application, monitor performance and synchronize overall drive behavior. User selectable profiling modes include S-curve, trapezoidal, velocity contouring and electronic gearing. Servo loop compensation utilizes PID control, velocity and acceleration feedforward, and dual bi-quad filters. Additional features include limit switches, breakpoints, secondary encoder input for master-slave and electronic gearing applications.

FEATURES

- DC Brush, Brushless DC and step motor versions
- Ethernet, CANbus or serial communications
- S-curve, trapezoidal, velocity contouring, electronic gearing profiles
- Pulse and direction input
- 500 W or 3000 W power rating
- Up to 20 A continuous, up to 30 A peak current
- 12-56 V or 20-195 V single power source
- High-efficiency MOSFETs
- 40 kHz PWM frequency
- 102 μ sec servo loop rate
- Auxiliary encoder input supports gearing and dual loop applications
- Position and current loops
- Field oriented control
- Sinusoidal commutation
- Stall detection and auto current reduction
- Programmable acceleration and deceleration
- Advanced PID filter with velocity and acceleration feedforward
- Programmable dual biquad filters
- +/- 10V high resolution 16-bit ADC input
- Up to 8 general purpose user inputs and 6 general purpose outputs
- Execution of C-Motion code at up to 96 MIPS
- 256 KB of programmable user code space
- C-Motion Engine development tools

CONFIGURATION

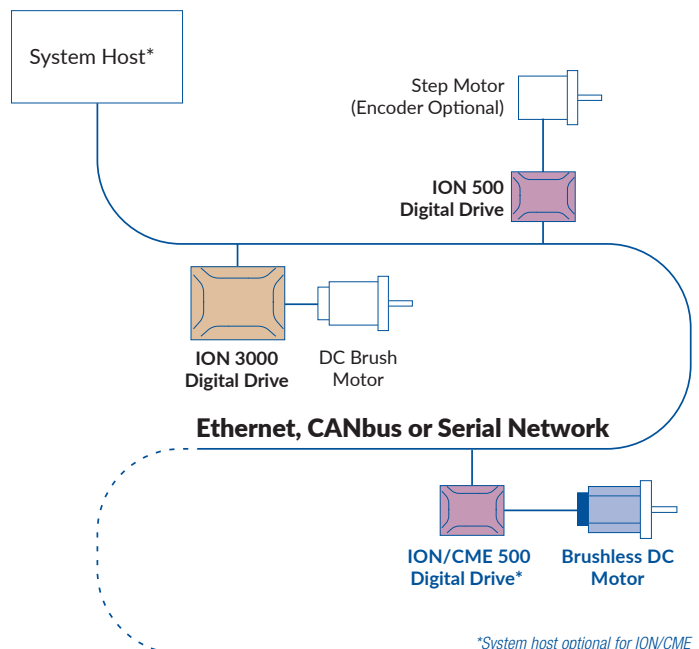

*System host optional for ION/CME

Technical Overview

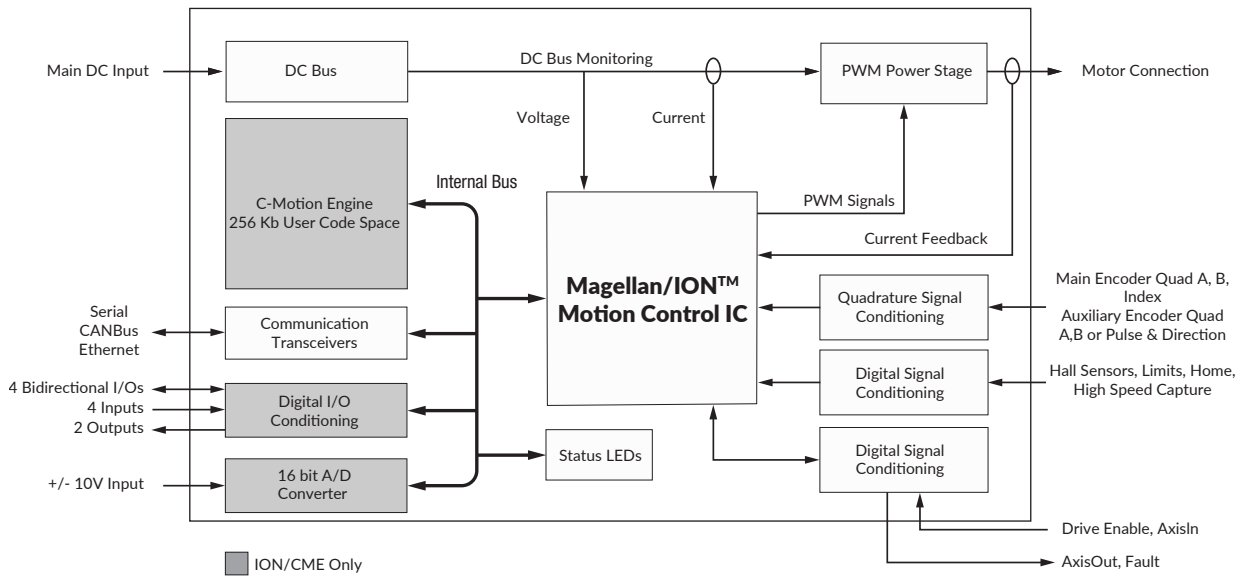

Specifications	ION 500	ION/CME 500	ION 3000
Supported Motor Types	DC Brush, Brushless DC, step motor		
Voltage Input	12-56 VDC	12-56 VDC	20-195 VDC
DC Brush Continuous current output	9.8 ADC	9.8 ADC	20 ADC
DC Brush Peak current output	21 ADC (2 sec)	21 ADC (2 sec)	30 A
DC Brush Continuous power output	500 W	500 W	3000 W
Brushless DC Continuous current output	8 A rms	8 A rms	15 A rms
Brushless DC Peak current output	15 A rms (2 sec)	15 A rms (2 sec)	30 A (per phase)
Brushless DC Continuous power output	500 W	500 W	2500 W
Step Continuous current output	5 A rms	5 A rms	30 A (per phase)
Step Continuous power output	350 W	350 W	1500 W
Supported communication options	RS232/485, CANbus, Ethernet	RS232/485, Ethernet	RS232/485, CANbus
Brushless DC commutation modes	Sinusoidal, 6-step, field oriented control		
Microstepping resolution	256 μ steps/step		
PWM frequency	20 kHz or 40 kHz (user selectable)		
Loop rates	Commutation and current loop: 51.2 μ sec; Position loop and trajectory generator: 102.4 μ sec to 1.6 sec		
C-Motion Engine MIPS	NA	Execute CME code @ up to 96 MIPS	NA
User Program Size	NA	256 KB Flash	NA
User RAM	NA	48 KB RAM	NA
Differential Inputs	Encoder A, Encoder B, Index, Aux Encoder A, Aux Encoder B		
Digital Inputs	Hall A, Hall B, Hall C, Home, +Limit, -Limit, AxisIn, High-speed capture		
Digital Output	AxisOut		
Additional I/Os	NA	4 digital bidirectional I/Os, 2 digital outputs, 4 digital inputs	NA
Analog Input	NA	+/- 10 V range and 16 bits resolution	NA
Short Circuit Protection	Line-to-line, line-to-power supply and line-to-case		
Interlocks	Enable input, fault output, over/under voltage & overtemperature shutdown		
Operating Temperature	0 degrees to 40 degrees C		0 degrees to 40 degrees C
CE/RoHS Compliance	EN60204-1, EN55011, EN61000-6-1, EN61000-6-3 CE marked; RoHS compliant		
UL Compliance	Designed to UL508c		UL Recognized
Mechanical Dimensions	4.3" (109.2 mm) x 3.03" (76.9 mm) x 1.63" (41.4 mm)		5.75" (146 mm) x 3.88" (98.5 mm) x 1.63" (41.4 mm)
Weight	0.6 lb (0.28 kg)	0.6 lb (0.28 kg)	1 lb (0.5 kg)

Development Tools

1 EASY START-UP Developers Kit

INCLUDES

- ION 500, ION/CME 500, or ION 3000 Developer's Kit available
- Pro-Motion software
- Software Development Kit (SDK) with C-Motion
- Complete manual set
- Complete cable and prototyping connector set

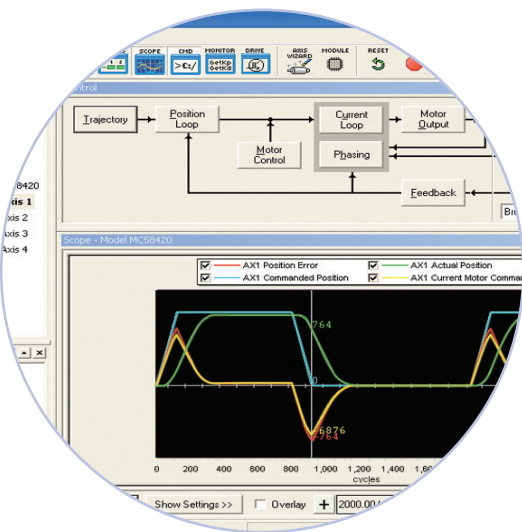

2 TUNE & OPTIMIZE Pro-Motion® GUI

Pro-Motion is a sophisticated, easy-to-use Windows-based exerciser program for use with PMD motion control ICs, modules, and boards.

FEATURES

- Motion oscilloscope graphically displays processor parameters in real-time
- Autotuning
- Ability to save and load settings
- Axis wizard
- Distance and time units conversion
- Motor-specific parameter setup
- Axis shuttle performs programmable motion between two positions
- Communications monitor echoes all commands sent by Pro-Motion to the board
- Advanced Bode analysis for frequency machine response

3 BUILD THE APP C-Motion®

C-Motion is a complete, easy-to-use, motion programming language that includes a source library containing all the code required for communicating with PMD motion ICs, boards, and modules.

C-MOTION FEATURES INCLUDE:

- Extensive library of commands for virtually all motion design needs
- Develop embeddable C/C++ applications
- Complete, functional examples
- Supports PC104, serial, CAN, Ethernet, and SPI communications

