

DLA-170

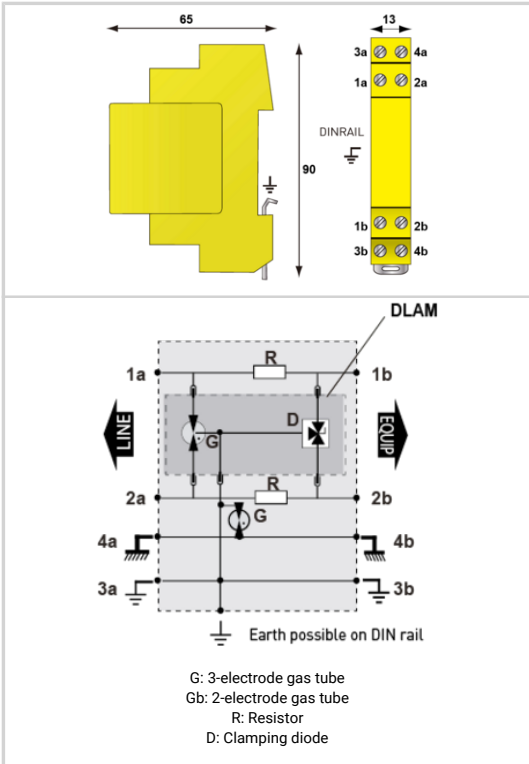

- ↳ Hybrid SAD-GDT Technology
- ↳ UL497B LISTED
- ↳ 20kA I_{max} (1x-8/20us)
- ↳ 5kA I_{imp} (2x-10/350us)
- ↳ 10kA I_n (10x-8/20us)
- ↳ Modular
- ↳ 2W+SHIELD+G



Electrical Characteristics	
Insertion loss	< 1 dB
Max. load current	IL 300 mA
Impulse current 2 x 10/350µs Test - D1 Category	I _{imp} 5 kA
Nominal discharge current C2 Category	I _n 2.5 kA
DATA SPD TYPE	UL497B LISTED
VOLTS	(V) 150
WIRES	RJ11 Connector
LINE CURRENT MAX	(A) 0.3
AMBIENT MIN	(C) -50
AMBIENT MAX	(C) +85
RESIDUAL VOLTAGE	(V) 210
MCOV	(V) 170
IN10 impulses 8/20µs	(kA) 2.5
IMAX8/20µs	(kA) 20
I _{imp} 10/350µs	(kA) 5
DATA SPEED	(bps) up to 10MHz
FREQUENCY	(MHz) up to 10
INSERTION LOSS (@ FREQ)	(db) < 1
CAPACITANCE	(pF) < 50
Mechanical Characteristics	
TECHNOLOGY	SAD-GDT
NETWORK CONFIGURATION	1 pair
CONNECTION METHOD	RJ11 Connector
MOUNTING	Wall mount
MATERIAL	Thermoplastic UL94-V0
NEMA RATING (IP RATING)	NEMA 2 (IP20)
DIMENSIONS	See diagram
WEIGHT	0.30 lbs
SPARE PART	DLAM-170D3
Standards	
Certification	UL479A
UL STANDARD	UL497B
UL CATEGORY	QVGQ
UL FILE NUMBER	E184939
STANDARDS	IEC 61643-11, NOM-003-SCFI-2014, NOM-001-SCFI-1993
ENVIRONMENTAL STANDARDS	ROHS
Part number	
6406011	