



Data Sheet	DMM-4326-T-EB-R
------------	-----------------

PUI Audio is proud to release a line of premium, high-fidelity MEMS wide-band microphones that cover the entire audio band from 20 Hz up to 18 kHz —and up to 20 kHz on some models—while featuring industry-best consistency of ± 1 dB across the entire frequency response.

Quickly test and prototype the top-firing digital **DMM-4326-T-R** with this evaluation board. Solder pads with pre-punched through-holes make wiring to the evaluation board quick-and-easy!

Microphone Specifications

Parameters	Condition	Values	Units
Directivity	Omnidirectional		
Sensitivity	1 kHz @ 50cm with 94 dB source 0 dB=1V/Pa	-26 \pm 1	dB
Data Format	1/2 Cycle PDM		
Rated Voltage	-	1.8	VDC
Operating Voltage Range	-	1.5 to 3.6	VDC
Current Draw	Full Power Mode	650 ~ 1000	μ A
	Low Power Mode	280 ~ 450	μ A
Signal-to-Noise Ratio (1kHz, 94 dB input, A-weighted)	Full Power Mode	59	dB
	Low Power Mode	57	dB
Frequency Range	20~18,000		Hz
Total Harmonic Distortion (typical)	94 dB @ 50cm, 1 kHz acoustic source	0.5%	-
Acoustic Overload Point (10% THD @ 1 kHz, acoustic source 50cm away from microphone)	Full Power Mode		123 dB
	Low Power Mode		120 dB
Environmental Compliances	RoHS/Halogen Free		
Power Supply Rejection	100 mVpp Square Wave @ 217 Hz, A-weighted	-86	dBFS
Load Capacitance	140		pF
Max Voltage on any Pin	4		VDC
Maximum SPL Before Damage (Source 50cm from microphone)	160		dB
Max Mechanical Shock	10,000		Gs
Max Vibration	Pre-MIL-STD-883 Method 2007, Test Condition B		
Operating Temp (VDD <3.0V)	-40 ~ +100		°C
Operating Temp (VDD >3.0V)	-40 ~ +70		°C
Storage Temperature	-40 ~ +125		°C

Operational Settings

Parameters	Condition	Values	Units
Clock Frequency	Sleep Mode	0 ~ 250	kHz
	Low Power Mode	500 ~ 800	kHz
	Full Power Mode	1.03 ~ 4.80	MHz
Duty Cycle	For fCLK ≤ 2.4 MHz the duty cycle must be in the range of 40 ~ 60% and for fCLK > 2.4 MHz the duty cycle must be 50%	40 ~ 60	%
Logic Input High	-	0.75*VDD ~ VDD + 0.3V	
Logic Input Low	-	-0.3 ~ 0.25*VDD	
Logic Output High	-	0.75*VDD ~ VDD + 0.3V	
Logic Output Low	-	-0.3 ~ 0.25*VDD	

Timing Characteristics

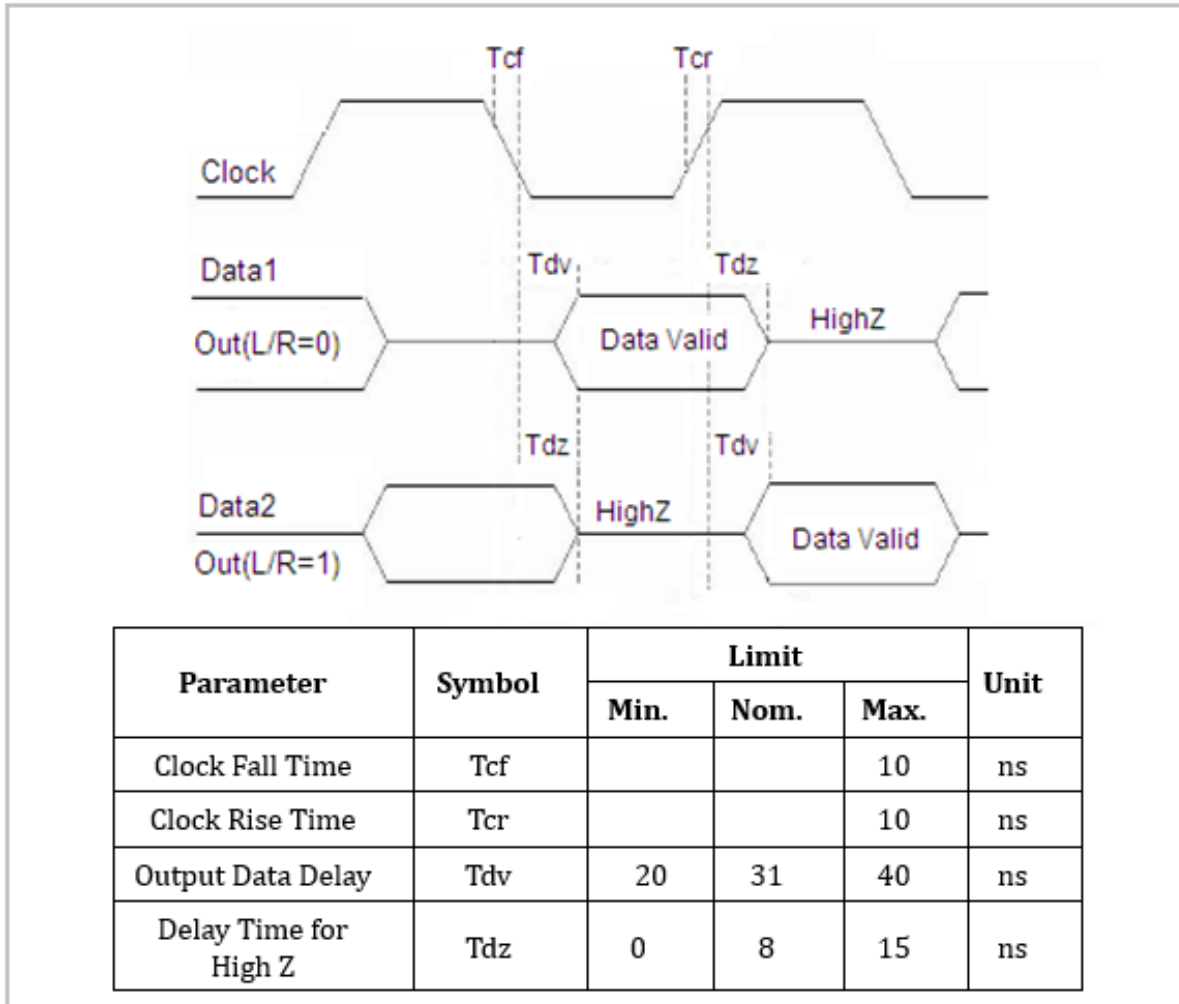

Measurement Method

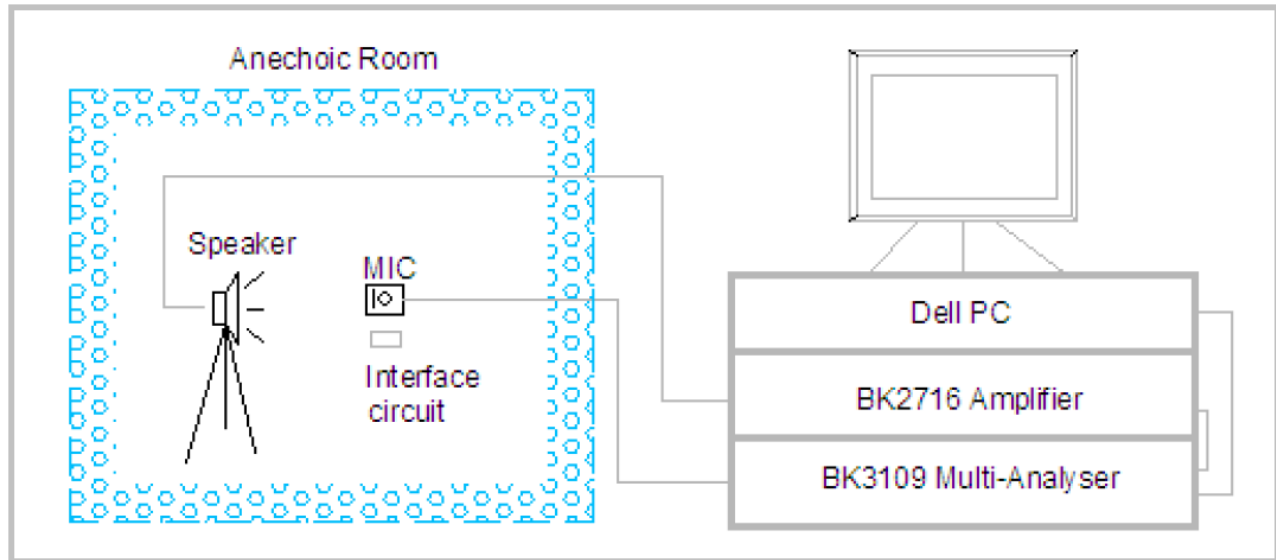

Measurement Interface Circuit

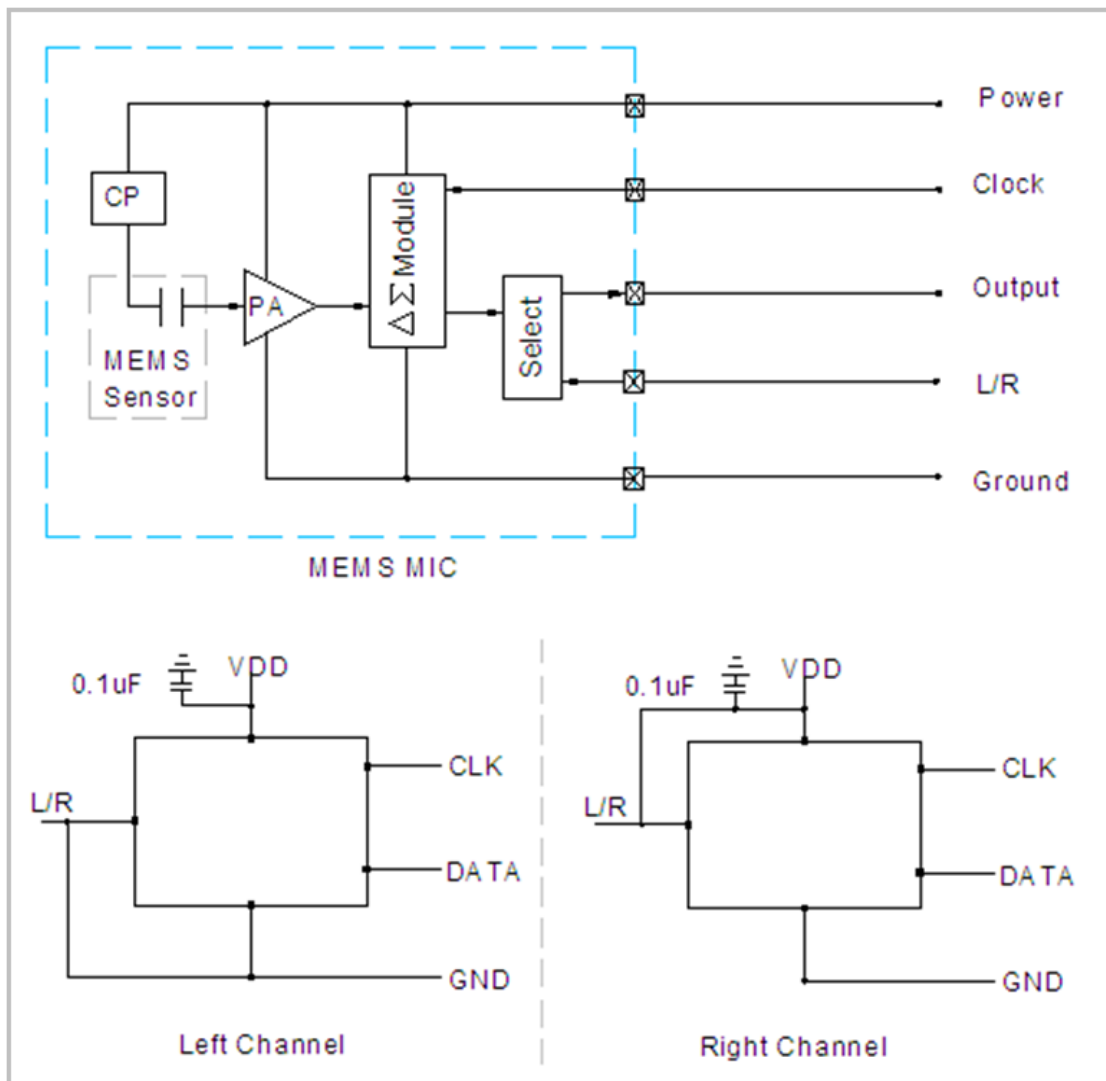

Typical Frequency Response

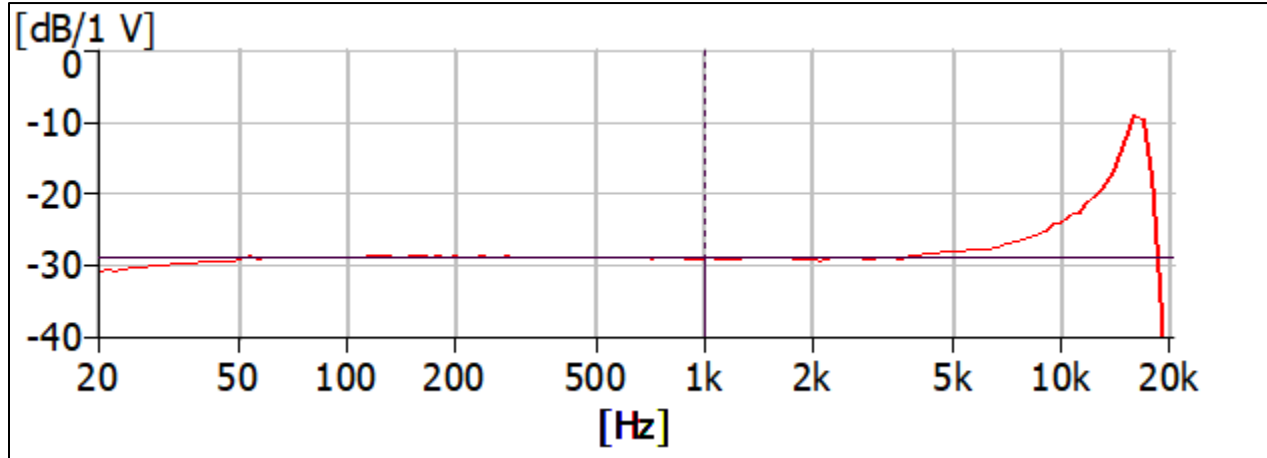

Frequency Response Mask (100% Pass/Fail Test for Microphones)

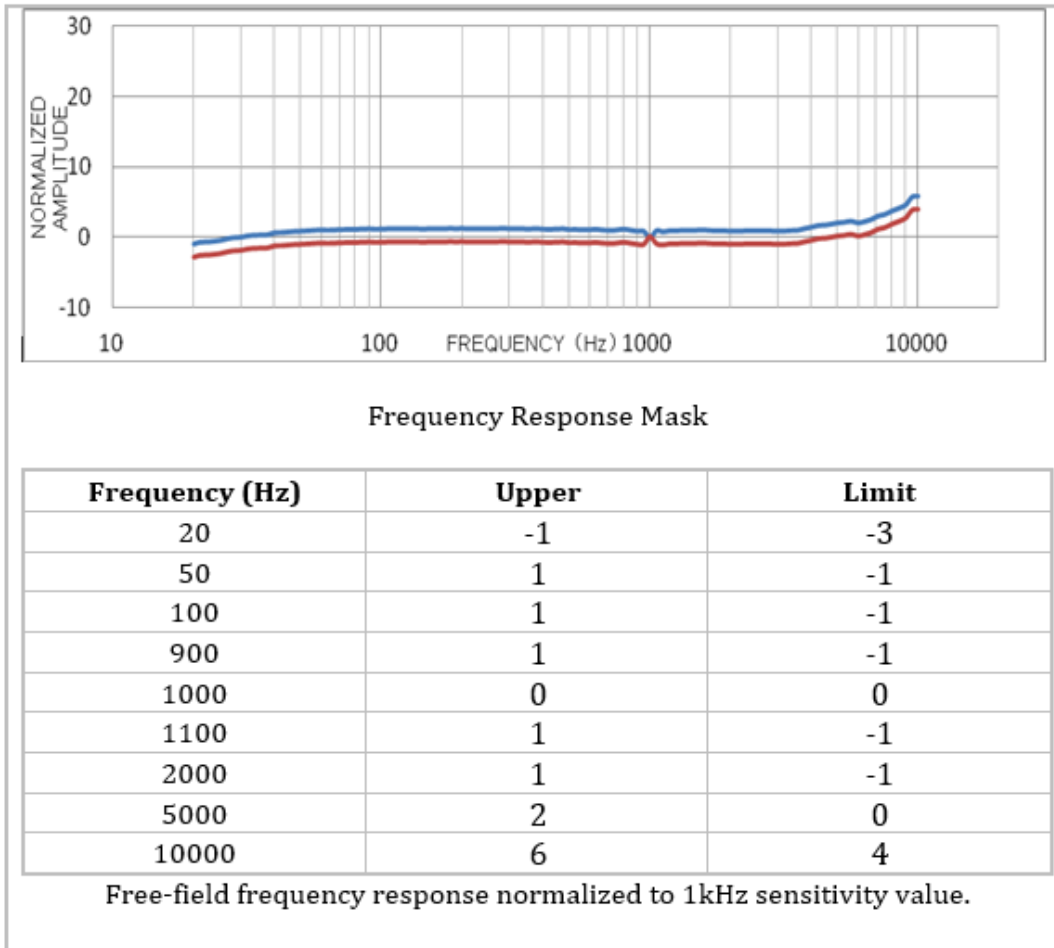

Total Harmonic Distortion + Noise versus SPL Input (with acoustic source at 50cm)

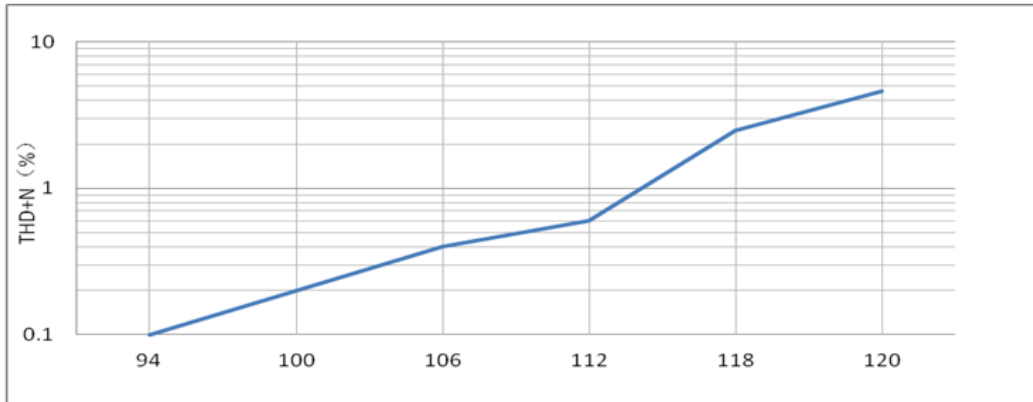

Microphone Output versus SPL Input (with acoustic source at 50cm)

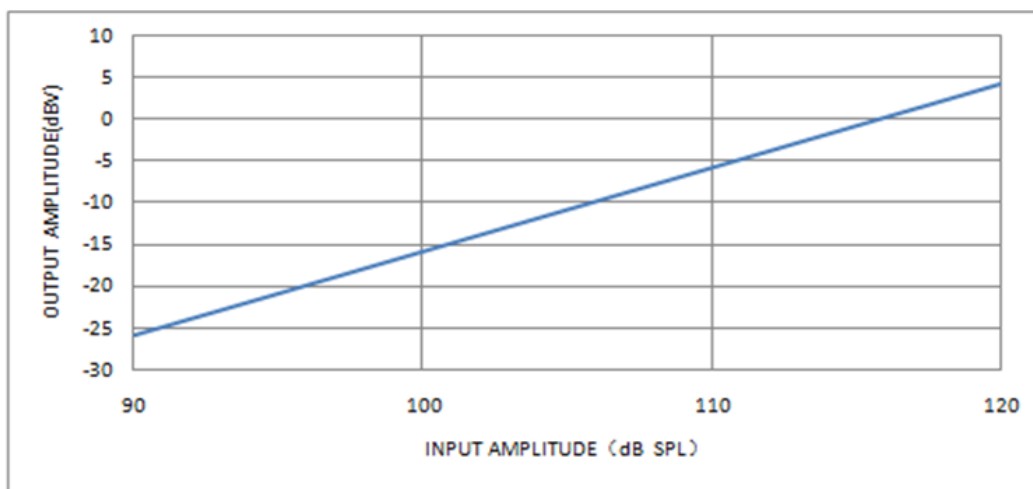

Ultrasonic Frequency Response (Sensitivity normalized to 0 dB)

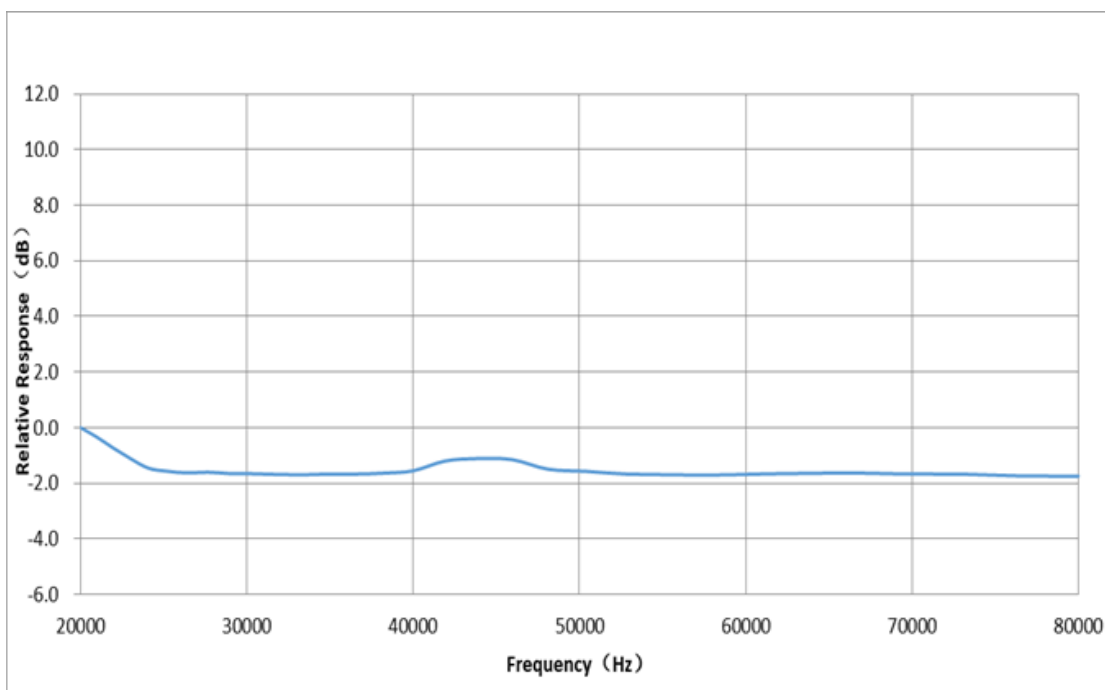

Reliability Testing

Type of Test	Test Specifications
Simulated Reflow (Without Solder)	Samples for qualification testing require 3 passes 260±5 °C reflow solder profiles. 2 hours of setting time is required between each reflow profile test.
Static Humidity	Precondition at +25°C for 1 hour. Expose to +85°C with 85% relative humidity for 1000 hours. Dry at room ambient for 3±1 hour before taking final measurement.
Temperature Shock	Each cycle shall consist of 30 minutes at -40°C, 30 minutes at +125°C with 5 minutes transition time. Test duration is for 30 cycles, starting from cold to hot temperature.
ESD Sensitivity	Perform ESD sensitivity threshold measurements for each contact according to MIL-STD-883G, Method 3015.7 for Human Body Model. Identify the ESD threshold levels indicating passage of 8000V Human Body Model.
Vibration Test	Vibrate randomly along three perpendicular directions for 30 minutes in each direction, 4 cycles from 20~2000 Hz with a peak acceleration of 20 Gs.
Shock Test	Subject samples to half-sine shock pulses (3000±15% Gs for 0.3ms) in each direction, for a total of 18 shocks.
Drop Test	Drop samples from 1.5m height onto a steel surface, total 18 times and inspected for mechanical damage.
Operation Life	Subject samples to +125°C for 168 hours under full maximum rated voltage.

Microphone frequency response and sensitivity shall not deviate more than ±3 dB.

Dimensions

