

Digital Mixed-Signal Power Manager Quickstart Card

Kit Contents – DMPM-DC-KIT

Quantity	Description
1	Digital Mixed-Signal Power Manager Daughter Card Kit
1	9 V power supply
1	USB A/B cable
1	USB-ISS – USB to I2C communication module
3	Jumper wires

Note: The DMPM-DC-KIT is RoHS compliant.

Overview

Microsemi's Digital Mixed-Signal Power Manager (DMPM) Kit enables system designers to evaluate the functionality of Microsemi's power management solutions in hardware with a five-regulator benchtop power management development system. The MPM Daughter Card includes two analog regulators, three digital point-of-load (POL) power supplies, two voltage bias potentiometers, and five fault introduction push-button switches, implementing five fully independent power supplies that can be varied and interrupted to demonstrate the management capabilities of Microsemi's mixed signal power management solution, MPM.

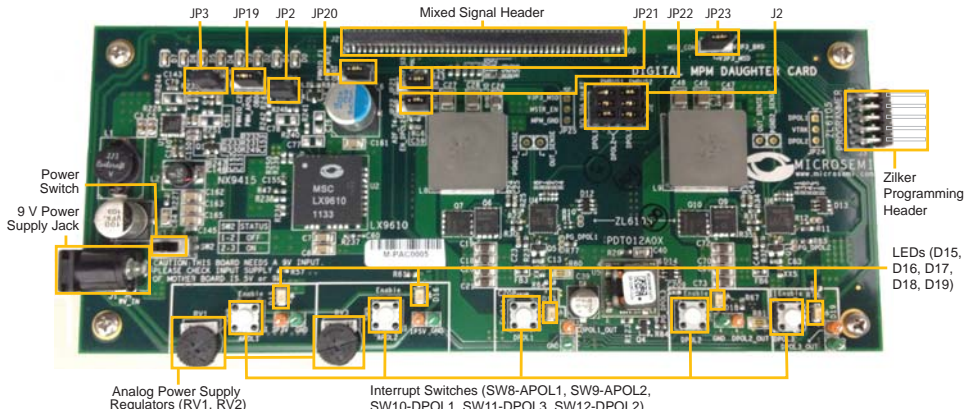

Connections, Jumper Switches, and Settings

Confirm that jumpers are in the default settings to enable the MPM for SmartFusion[®] design to function correctly before powering up the boards.

- Jumpers for I²C setup in J2 bank
 - J2A pin 1–J2B pin 2
 - J2C pin 3–J2D pin 4
 - J2A pin 6–J2B pin 7
 - J2C pin 8–J2D pin 9
 - J2A pin 11–J2B pin 12
 - J2C pin 13–J2D pin 14
- Jumpers for enabling trimming of APOL1 and APOL2
 - JP2 and JP3 populated
- RC and Trim resistors
 - JP19 and JP20 – pins 1–2
- Jumper option for DPOL enable signal
 - JP21 and JP22 – pins 1-2

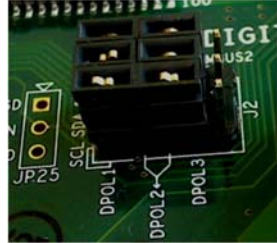

MPM Reference Design Demo

The MPM reference design takes advantage of the processing power and programmable flexibility of the SmartFusion customizable system-on-chip (cSoC) on the SmartFusion Evaluation Kit or Development Kit. Connect either kit to the daughter card and download the software as described to run the demo.

The daughter card consists of five regulated power supplies running from a 9 V supply.

- Two analog Microsemi switching regulators for 1.5 V and 3.3 V
- Two digital Intersil switching regulators for 1.5 V and 3.3 V
- One digital Lineage switching regulator for 1.5 V

Using the MPM design one can do the following:

- Monitor voltage for all rails
- Sequence different power rails for power-up and power-down
- Trim and margin a voltage rail in a closed loop
- Sweep the output voltage (POT circuit to change resistor on feedback voltage)
- Induce failures by disabling the enable input of regulator (push-button to GND enable)

Power sequencing is done by sequentially asserting or deasserting channel enable pins for power-up and power-down, respectively, and monitoring the associated channel voltage. All enable pins to the regulator are active high.

Software for MPM Reference Design

Download the MPM executable, which contains the demo design, from the Microsemi website:

www.microsemi.com/soc/products/hardware/devkits_boards/mpm_v4_dc.aspx

Run the demo design executable. This will install the MPM GUI. From the MPM GUI you can program the demo design into the SmartFusion device and configure your power sequence or trimming. You can update the sequence by uploading only the NVM register locations after the first time you program the main design to the board.

Running the MPM Reference Design

With the SmartFusion Evaluation Kit – Connect the MPM daughter card to the A2F-EVAL-KIT board. Connect both USB cables from your PC to the evaluation kit. One USB provides power and UART connection; the other provides the programming connection.

With the SmartFusion Development Kit – Connect the MPM daughter card to the A2F-DEV-KIT board. Connect the 9 V power supply to the MPM Daughter Card and the 5 V power supply to the development kit. It is a good idea to double-check the voltages before connecting the supplies. Connect the low-cost programming stick to the development kit and connect with a USB cable to the PC for programming. Also connect the other USB cable to the USB connection on the board and to your PC.

From the MPM GUI, select **Data > FlashPro > Choose STAPL Template** to load the correct MPM design and then select **Data > FlashPro > Write NVM & Fabric** to load the design into the device for the first time. Use the switches on the evaluation or development kit to activate the power-up sequence. You can then create interrupts and change POT settings to review the performance of the board. The OLED shows the voltage of each of the first four power rails.

- SW1 initiates MPM power-up or power-down, depending on current state
- SW2 moves to the next OLED “screen” (e.g., next channel details)

To change the power sequence, use the GUI to change the settings and then do **Data > FlashPro > Write NVM** to update the register settings. It is not necessary to write the fabric again.

The demo design has many capabilities. To fully understand and use power management, please refer to the documentation.