

DC Server Fans



Wakefield Thermal produces a line of DC server fans from 40x28mm to 120x38mm with the most common sizes in between. The fans are available in 12 volt as the most common, but other voltages (5, 24 and 48) are possible upon request. The standard configuration is 4 wire (PWM) which can be customized to support any range of connectors.



General Specifications

Operation Temperature:

-10C to +70C (+14F to +158F)

Storage Temperature:

-40C to +75C (-40F to +167F)

Bearing System Life:

2 Ball Bearing: L10 - 70k hrs @ 40C

Materials:

Black PBT(UL94V0), Glass Filled

Lead Wires:

Rating: UL1007 or UL1571, 80C

AWG: 24 or 26

Wire Length: 300mm +/- 10mm

3rd Wire Standard: Red(+), Black(-), Yellow(Tach/FG)

4th Wire Optional: Blue (PWM)

Insulation Resistance:

Standard: 10M Ω at 500VDC Minimum(frame to leads)

Dielectric Strength

Standard: 500VAC(50/60Hz) for 60 seconds with 1mA trip current allowable between frame and leads

Noise Data:

All noise readings are taken in dBA at 1meter from air intake side, fan suspended in a semi-anechoic chamber (<16 dBA max)

Protection:

Locked Rotor (Meets UL standard 72 hr test)

Reversed Polarity

Shock and Vibration:

Shock: Meets 100G at 2ms, half sine, X, Y, and Z axis

Vibration: Meets the amplitude of vibration :0.38mm

Frequency: 5-55 Hz

Duration: 60min / axis

Direction: X.Y.Z axis

PART NUMBERING GUIDE

Example: DS0603812U2B-BT0

Series	Frame Size (mm)	Thickness (mm)	Voltage	Speed	Bearing	# of Wires	Termination
DS	60	38	12	U	2B	B	T0

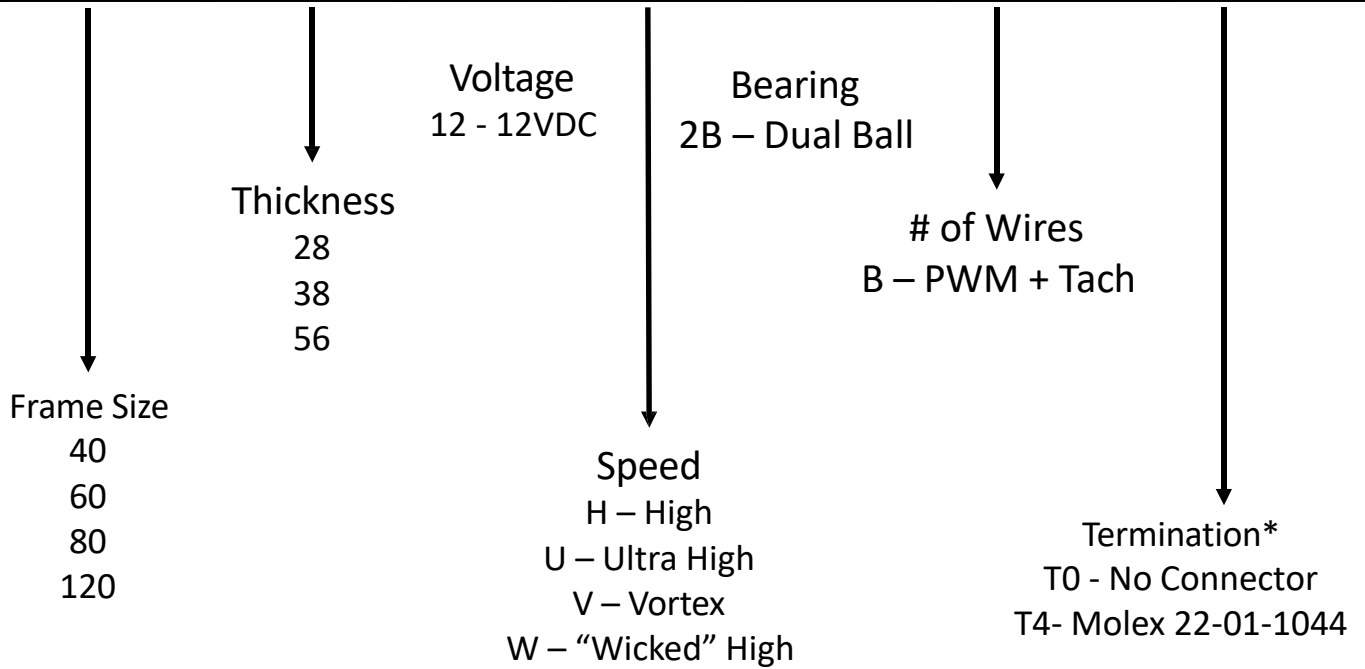

Dual Ball Bearing

The two ball bearing system is the industry standard for long life with a L10 of 70,000 hours. Other bearing choices, like sleeve or single ball are susceptible to impact damage which is why they can not support the high life requirement of most applications. One advantage of two ball bearing systems is that due to the small point load of the balls, they require less power to start rotation as they have less stiction (starting friction) than other bearing system which means the minimum starting power can be achieved with a lower current.

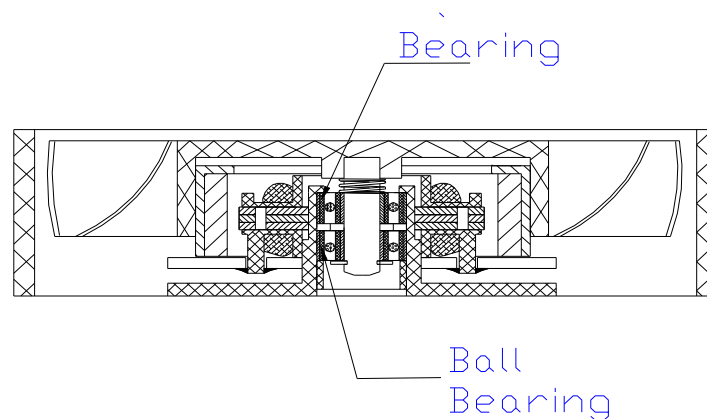

Bearing Lubrication, Wear and Failure

Bearing failure is the most common reason for a fan failure which is why bearing selection is so important. The bearing failure can be caused by multiple factors including lack of lubrication, excessive temperature or direct damage (excessive shock/vibration). A two ball bearing fan is better sealed to prevent the leak of the lubrication fluid than some of the other bearing systems. All fans typically will get noisier and rotate slower as the bearing systems wear and this can be a good indicator of pending bearing failure.

STANDARD CONFIGURATION

- B – PWM + Tach

PWM CONTROL

SIGNAL DESCRIPTION

1. CONTROL SIGNAL: PWM CONTROL
2. SIGNAL TYPE:
INPUT HIGH LEVEL VOLTAGE: MIN. >2.6V , MAX.<5V
INPUT LOW LEVEL VOLTAGE: MAX.<0.5V
3. PWM FREQUENCY RANGE: 20K-100KHZ
4. MAX. SINK CURRENT: 8mA

FAN SPEED CONTROL

1. INPUT VOLTAGE: 5 VDC
2. PWM FREQUENCY : 25 KHZ
3. THE FAN SPEED SHOULD RUN AT FULL SPEED GIVEN PWM 100% DUTY CYCLE INPUT.
4. THE FAN SPEED SHOULD RUN AT ZERO SPEED GIVEN BELOW PWM 0 % DUTY CYCLE INPUT.
5. THE FAN WILL GO TO FULL SPEED WHEN IF THE CONTROL SIGNAL IS DISCONNECTED.

FREQUENCY GENERATOR (FG) SIGNAL

SCHEMATIC

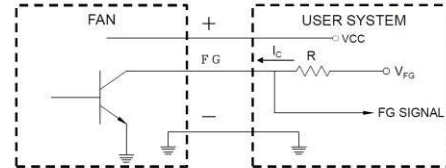

CAUTION:

THE LEAD WIRE OF FG SIGNAL CAN NOT TOUCH THE LEAD WIRE OF POSITIVE OR NEGATIVE

SIGNAL SPECIFICATION:

OUTPUT TYPE: OPEN COLLECT
 V_{FG} MAXIMUM VOLTAGE=13.2V
 I_C MAXIMUM CURRENT= 5mA
 LOW LEVEL VOLTAGE= 0.5V MAX
 $R \geq V_{FG} / I_C$

FREQUENCY GENERATOR WAVEFORM

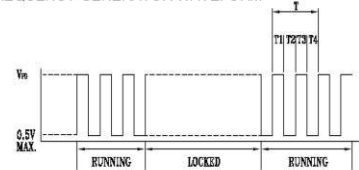

$$T = T_1 + T_2 + T_3 + T_4 = 60/N(\text{Sec}) \quad N: \text{SPEED (RPM)}$$

TERMINATION AND WIRING INFORMATION

- T0 – 5mm +/-2mm strip length, tinned



- T4 – Molex 22-01-1044*
 - Pin1 – Positive
 - Pin2 – Negative
 - Pin3 – Tachometer
 - Pin4 -- PWM

Lead Wire: UL10368 , AWG#24 , 300±10 mm lead length.

INLET:

RED WIRE----- (+)

BLACK WIRE----- (-)

YELLOW WIRE----- (FG)

BLUE WIRE----- (PWM)

OUTLET:

ORANGE WIRE----- (+)

GRAY WIRE----- (-)

WHITE WIRE----- (FG)

GREEN WIRE----- (PWM)

Typical Ordering Configurations

-BT0 (4 wire, no connector)

-BT4 (4 wire, 4 pin connector)

* Or approved equivalent

Wakefield Part Number	Description	Size (mm)	Thickness (mm)	Bearing System	Rated Voltage (VDC)	Rated Current (A)	Rated Power (W)	Rated Speed (RPM)	Speed Code	Max Airflow (CFM)	Max Pressure (InAq)	Noise Level (dB/A)
DS0402812V2B-BT0	DC Server Fans 40 X 40 X 28 35.0CFM	40	28	2B	12	2.34	28.08	30000	V	35.02	5.888	67.5
DS0402812W2B-BT0	DC Server Fans 40 X 40 X 28 41.2CFM	40	28	2B	12	4.20	50.4	35000	W	41.2	8.112	72.5
DS0405612V2B-BT0	DC Server Fans 40 X 40 X 56 37.6CFM	40	56	2B	12	3.60	43.2	32000/30500	V	37.63	9.561	82.5
DS0603812U2B-BT0	DC Server Fans 60 X 60 X 38 78.1CFM	60	38	2B	12	3.36	40.32	21500	U	78.1	4.744	71.5
DS0605612U2B-BT0	DC Server Fans 60 X 60 X 56 87.8 CFM	60	56	2B	12	6.12	73.44	20500/23000	U	87.77	11.308	78.6
DS0803812U2B-BT0	DC Server Fans 80 X 80 X 38 123.7CFM	80	38	2B	12	4.20	50.4	15000	U	123.7	4.383	72.5
DS0805612V2B-BT0	DC Server Fans 80 X 80 X 56 138.1CFM	80	56	2B	12	6.96	83.52	17300/15000	V	138.07	8.811	79
DS1203812H2B-BT0	DC Server Fan 120 X 120 X 38 197.5CFM	120	38	2B	12	2.00	24	5500	H	197.46	1.126	60.2



40 X 40 mm



- MOTOR : DC single phase brushless motor
- FRAME : PBT (94V-0) ; IMPELLER : PBT(94V-0)
- OPERATING TEMP.: -10°C~70°C
- STORAGE TEMP.: -40°C~75°C
- WEIGHT : 49g for 28mm thick, 96g for 56mm thick
- Dual Ball Bearing
- Lead Length: 300mm +/- 10mm
- 4 Wire: Standard

WT Part Number	Description	Size (mm)	Thickness (mm)	Bearing System	Rated Voltage (VDC)	Rated Current (A)	Rated Power (W)	Rated Speed (RPM)	Speed Code	Max Airflow (CFM)	Max Pressure (InAq)	Noise Level (dB/A)
DS0402812V2B-BT0	DC Server Fans 40 X 40 X 28 35.0CFM	40	28	2B	12	2.34	28.08	30000	V	35.02	5.888	67.5
DS0402812W2B-BT0	DC Server Fans 40 X 40 X 28 41.2CFM	40	28	2B	12	4.20	50.4	35000	W	41.2	8.112	72.5
DS0405612V2B-BT0	DC Server Fans 40 X 40 X 56 37.6CFM	40	56	2B	12	3.60	43.2	32000/30500	V	37.63	9.561	82.5

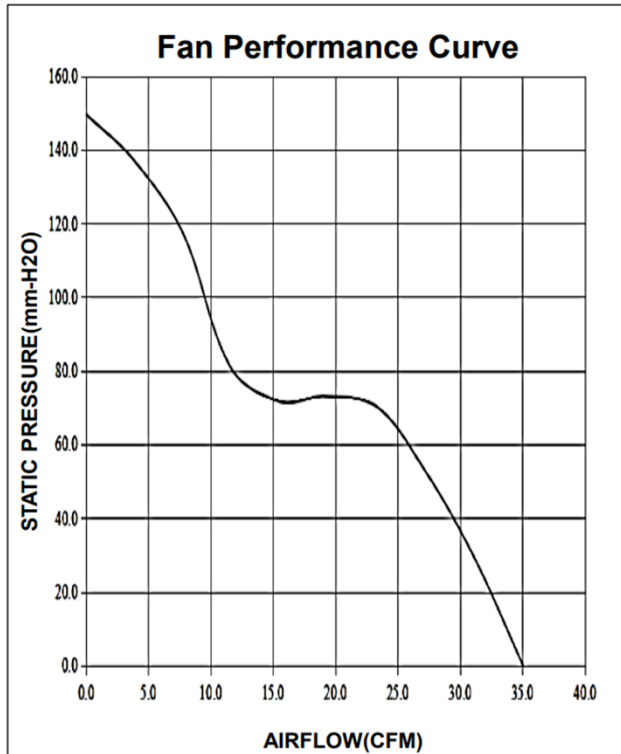

DS0402812V2B-BT0

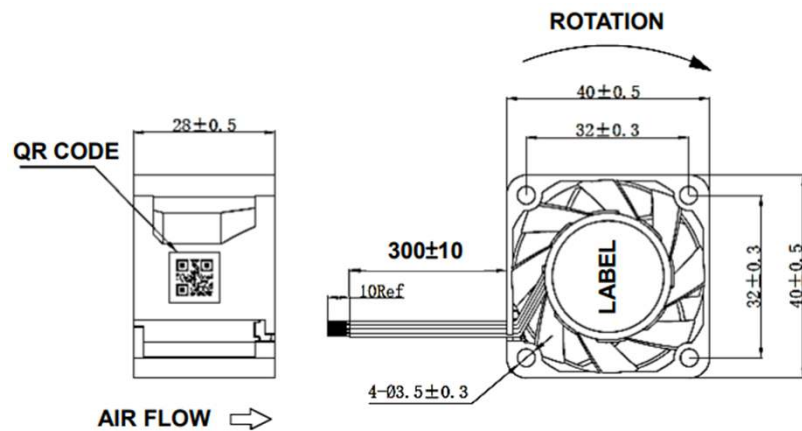

40 X 40 mm

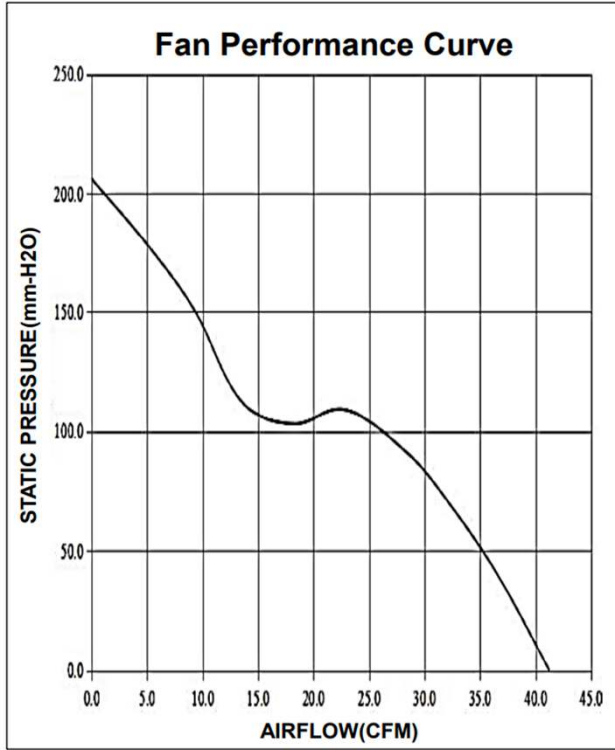

DS0402812W2B-BT0

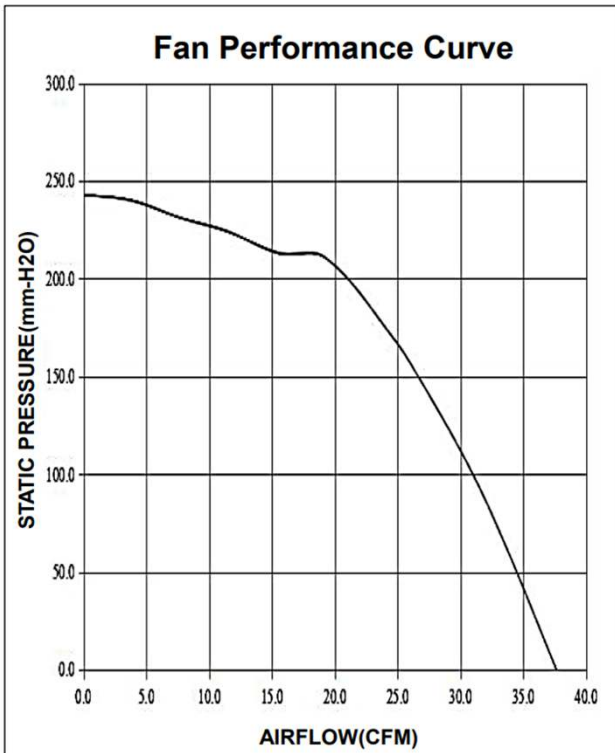
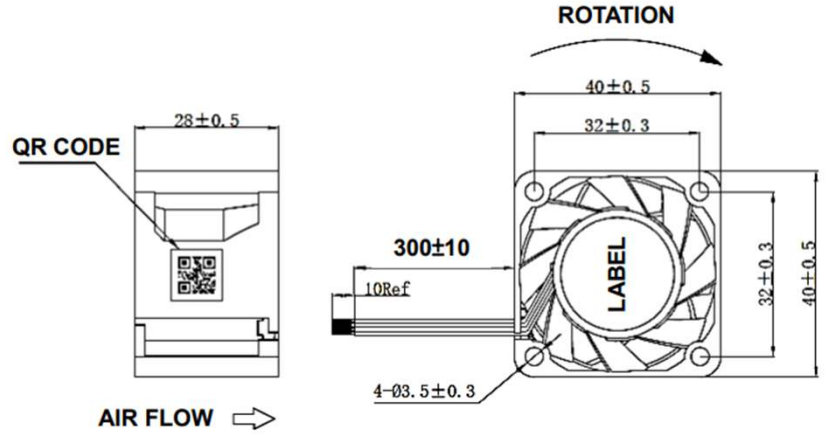

DS0405612V2B-BT0

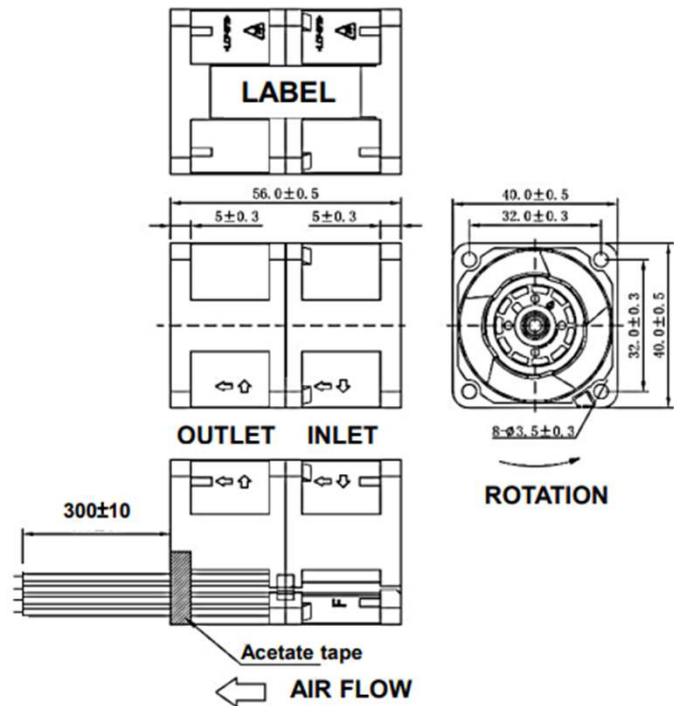

60 X 60 mm



- MOTOR : DC single phase brushless motor
- FRAME : PBT (94V-0) ; IMPELLER : PBT(94V-0)
- OPERATING TEMP.: -10°C~70°C
- STORAGE TEMP.: -40°C~75°C
- WEIGHT : 127g
- Dual Ball Bearing
- Lead Length: 300mm +/- 10mm
- 4 Wire: Standard

WT Part Number	Description	Size (mm)	Thickness (mm)	Bearing System	Rated Voltage (VDC)	Rated Current (A)	Rated Power (W)	Rated Speed (RPM)	Speed Code	Max Airflow (CFM)	Max Pressure (InAq)	Noise Level (dB/A)
DS0603812U2B-BT0	DC Server Fans 60 X 60 X 38 78.1CFM	60	38	2B	12	3.36	40.32	21500	U	78.1	4.744	71.5
DS0605612U2B-BT0	DC Server Fans 60 X 60 X 56 87.8 CFM	60	56	2B	12	6.12	73.44	20500/23000	U	87.77	11.308	78.6

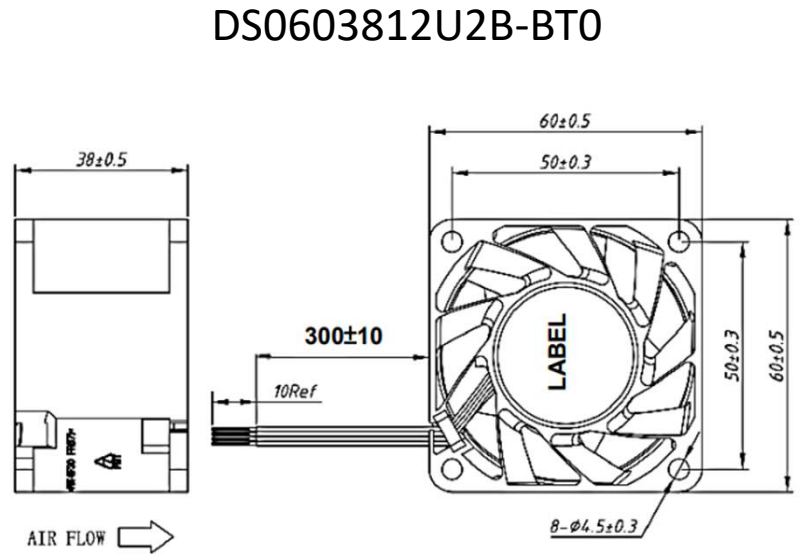
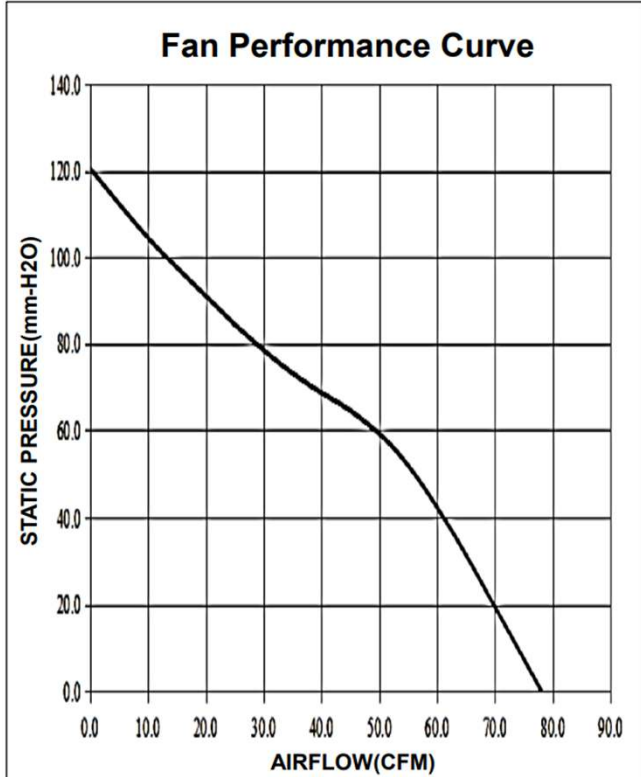

60 X 60 mm

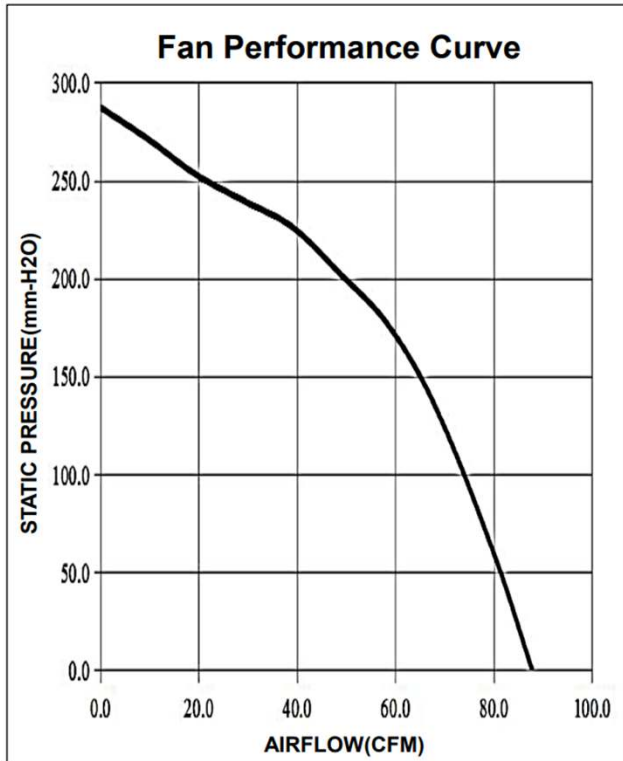

DS0605612U2B-BT0

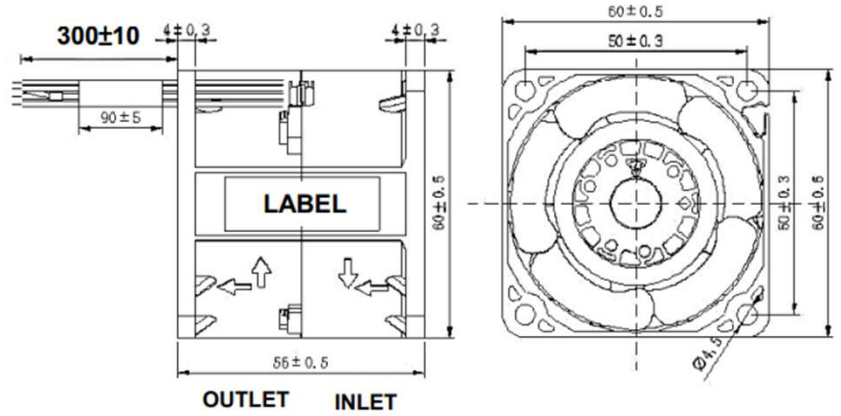

80 X 80 mm



- MOTOR : DC single phase brushless motor
- FRAME : PBT (94V-0) ; IMPELLER : PBT(94V-0)
- OPERATING TEMP.: -10°C~70°C
- STORAGE TEMP.: -40°C~75°C
- WEIGHT : 230g for 38mm thick, 357g for 56mm thick
- Dual Ball Bearing
- Lead Length: 300mm +/- 10mm
- 4 Wire: Standard

WT Part Number	Description	Size (mm)	Thickness (mm)	Bearing System	Rated Voltage (VDC)	Rated Current (A)	Rated Power (W)	Rated Speed (RPM)	Speed Code	Max Airflow (CFM)	Max Pressure (InAq)	Noise Level (dB/A)
DS0803812U2B-BT0	DC Server Fans 80 X 80 X 38 123.7CFM	80	38	2B	12	4.20	50.4	15000	U	123.7	4.383	72.5
DS0805612V2B-BT0	DC Server Fans 80 X 80 X 56 138.1CFM	80	56	2B	12	6.96	83.52	17300/15000	V	138.07	8.811	79

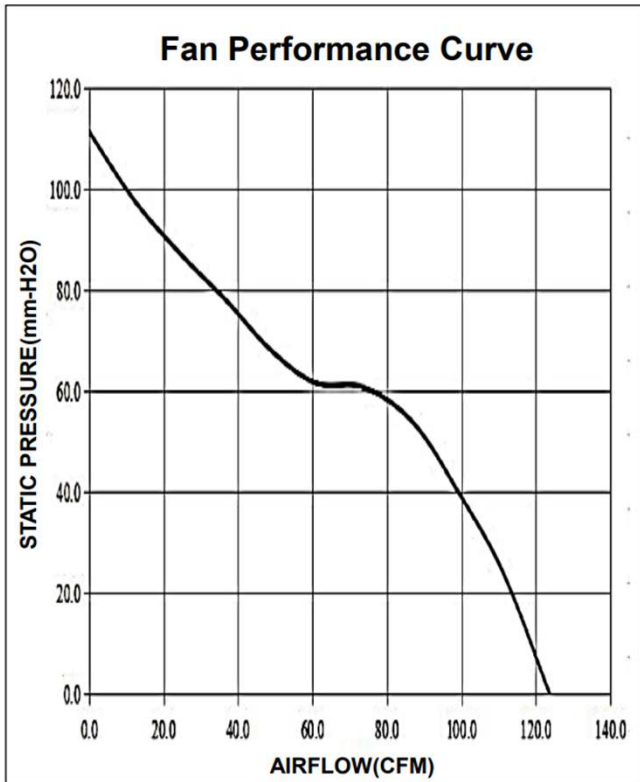

DS0803812U2B-BT0

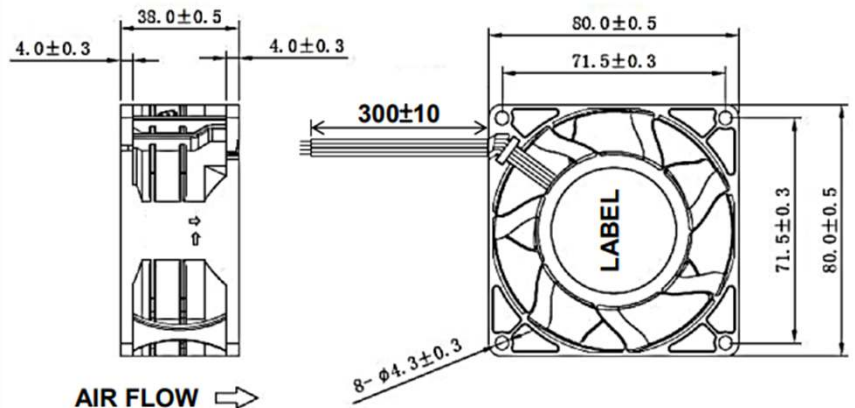

80 X 80 mm

DS0805612V2B-BT0

