

FEATURES

- Ultra-low power consumption
- Operates from 3V or 5V supplies
- Two digitally controlled, 65-position potentiometers including mute
- Logarithmic resistive characteristics (1 dB per step)
- Zero-crossing detection eliminates noise caused by wiper movement
- Serial port provides means for setting and reading both potentiometers wipers
- 14-pin PDIP, 16-pin SOIC, and 14-pin TSSOP packages
- Operating Temperature Range:
 - Industrial: -40°C to +85°C
- Software mute
- Resistance available: 45 kΩ

PIN DESCRIPTION

L0, L1	-	Low End of Resistor
H0, H1	-	High End of Resistor
W0, W1	-	Wiper End of Resistor
V _{CC}	-	3V or 5V Power Supply Input
RST	-	Serial Port Reset Input
D	-	Serial Port Data Input
CLK	-	Serial Port Clock Input
GND	-	Digital Ground
AGND	-	Analog Ground
ZCEN	-	Zero-Crossing Detect Input
C _{OUT}	-	Cascade Output
NC	-	No Connect

PIN ASSIGNMENT

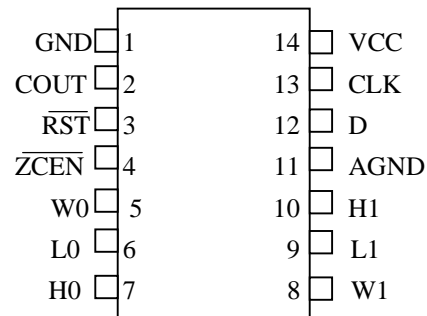

DS1801 14-Pin PDIP (300-mil)
 DS1801 14-Pin TSSOP (173-mil)

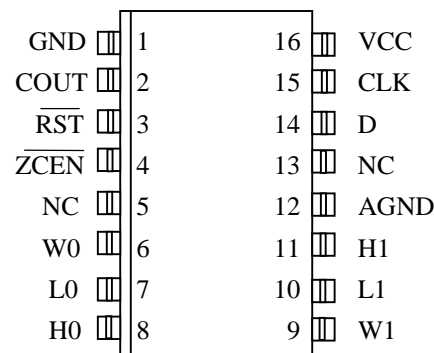

DS1801S 16-PIN SOIC (300-mil)
 See Mech. Drawings Section

DESCRIPTION

The DS1801 is a dual audio taper potentiometer having logarithmic resistive characteristics over the device range. Each potentiometer provides 65 wiper positions with a 1 dB increment per step and device mute. The 3-wire serial interface, using a CPU, provides the user the ability of reading or writing exact wiper positions of the two potentiometers. Additionally, the part contains a zero-crossing detection feature that minimizes noise resulting from wiper transitions. Packages for the part include a 14-pin PDIP, 16-pin SOIC, and 14-pin TSSOP.

OPERATION

The DS1801 provides two 65-position potentiometers per package, each having a logarithmic resistive characteristic as shown in Table 1. The DS1801 is controlled by a 3-wire serial interface. The 3-wire serial interface is designed for CPU-controlled applications and allows the potentiometer's exact wiper position to be read or written. The DS1801 design supports daisy-chaining for multi-device environments.

Figure 1 presents a block diagram of the DS1801. As shown, the inputs from the 3-wire serial interface drive a command/control unit. The command/control unit interprets these inputs for control of the two potentiometers.

On power-up, the serial port is stable and active within 10 microseconds. The wiper position on power-up will be at position 63, the low end of the potentiometer. Position 64 is the mute level.

RESISTANCE CHARACTERISTICS Table 1

POSITION	OUTPUT LEVEL (dB)
0	0
1	-1
2	-2
3	-3
4	-4
5	-5
63	-63
64(mute)	<-90

DS1801 BLOCK DIAGRAM Figure 1



3-WIRE SERIAL INTERFACE CONTROL

Communication and control of the DS1801 is accomplished through a 3-wire serial port interface that drives an internal control logic unit. The 3-wire serial interface is designed for microprocessor or microcontroller applications. The interface consists of three input signals which include $\overline{\text{RST}}$, CLK and D.

The $\overline{\text{RST}}$ control signal is used to enable 3-wire serial port write operations. The CLK terminal is a clock signal input that provides synchronization for data I/O while the D signal input serves to transfer potentiometer wiper position settings to the device.

As shown in Figure 3, a 3-wire serial port operation begins with a transition of the $\overline{\text{RST}}$ signal input to a high state. Once the 3-wire port has been activated, data is clocked into the part on the low to high transition of the CLK signal input. Data input via the D line is transferred in the order of the desired potentiometer-0 value followed by the potentiometer-1 value.

The DS1801 contains two 65-position potentiometers whose wiper positions are set by an 8-bit value. These two 8-bit values are written to the 16-bit I/O shift register which is used to store wiper position during powered conditions. Because the potentiometer has 65-positions, only 7 bits of data are needed to set wiper position. A detailed diagram of the 16-bit I/O shift register is shown in Figure 2. Bits 0 through 7 are reserved for the potentiometer-0 control while bits 8 through 15 are reserved for control of potentiometer-1.

Bits 0 through 5 are used for actual wiper positioning of potentiometer-0. Bit 6 is used to mute potentiometer-0. If this bit has value 1, the potentiometer-0 wiper will be connected to the low end of the resistive array the mute position. The value of bit 7 is a “don’t care” and will not affect operation of the DS1801 or potentiometer-0.

Bits 8 through 13 are used for wiper positioning of potentiometer-1. Bit 14 is used for muting of the potentiometer-1 wiper output. Bit 15, like bit 7, is a “don’t care” and will not affect operation of the DS1801.

Data for the DS1801 is transmitted LSB first starting with bit 0. A complete transmission of 16 bits of data is required to insure proper setting of each potentiometer’s wiper. An incomplete transmission may result in undesired wiper settings.

Once the complete 16 bits of information has been transmitted and the $\overline{\text{RST}}$ signal input transitions to a low state, the new wiper positions are loaded into the part.

16-BIT I/O SHIFT REGISTER Figure 2

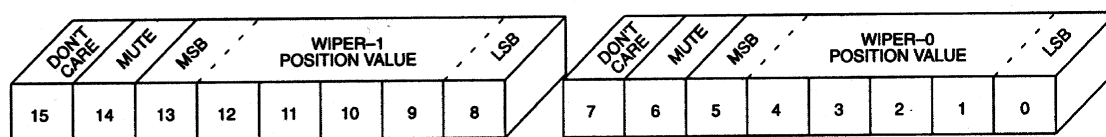

TIMING DIAGRAMS Figure 3

(a) 3-Wire Serial Interface General Overview

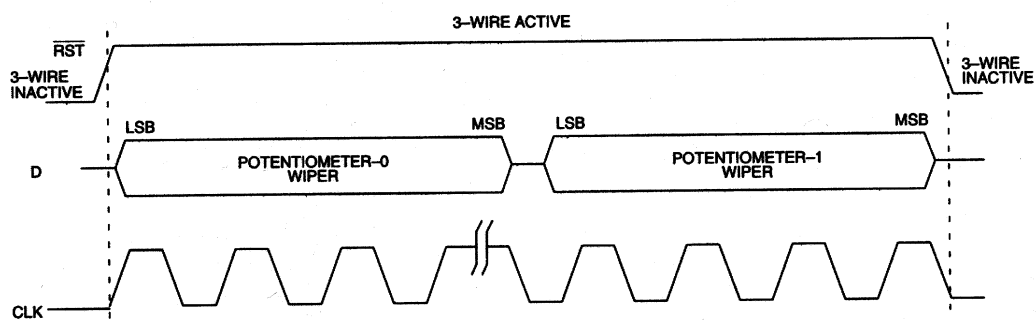

(b) Start of Communication Transaction

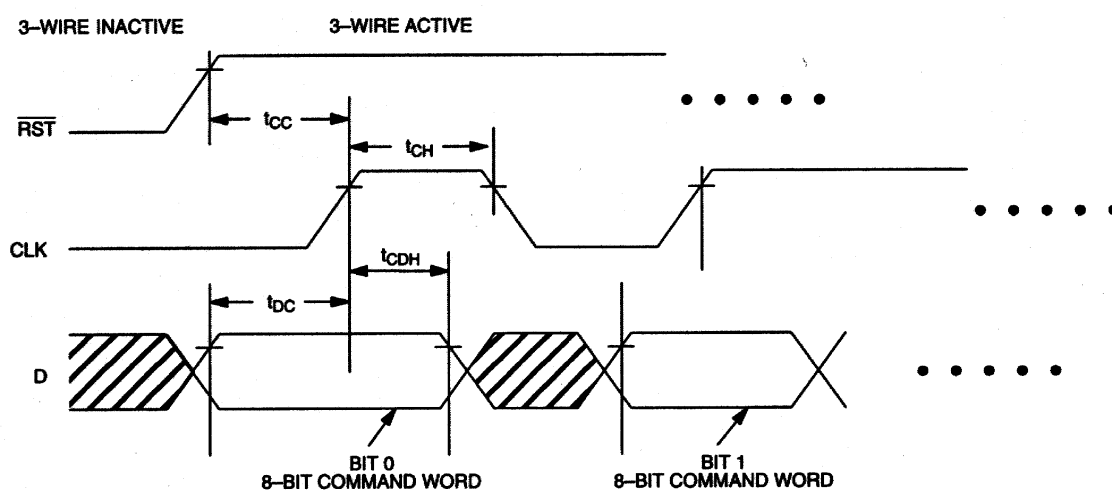

(c) End of Communication Transaction

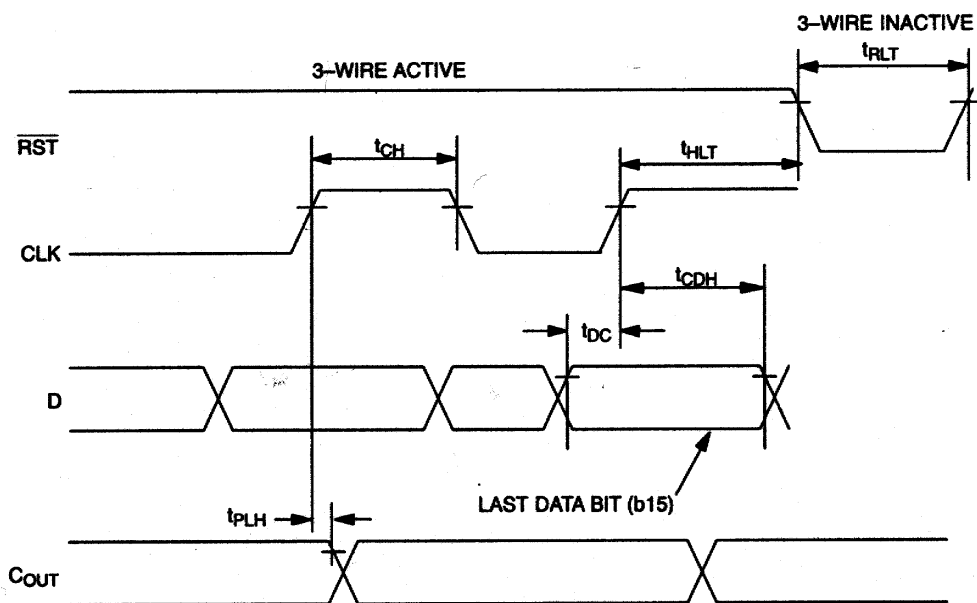

CASCADE OPERATION

A feature of the DS1801 is the ability to control multiple devices from a single processor. Multiple DS1801s can be linked or daisy-chained as shown in Figure 4. As a data bit is entered into the I/O shift register of the DS1801, bit 0 of the I/O shift register will appear at the C_{OUT} output after a maximum delay of 50 nanoseconds.

The C_{OUT} output of the DS1801 can be used to drive the D input of another DS1801. When connecting multiple devices, the total number of bits sent is always 16 times the number of DS1801s in the daisy chain.

An optional feedback resistor can be placed between the C_{OUT} terminal of the last device and the D input of the first DS1801 thus allowing the controlling processor to read as well as write data or circularly clock data through the daisy chain. The value of the feedback or isolation resistor should be in the range from 2 to 10 kohms.

When reading data via the C_{OUT} pin and isolation resistor, the D line is left floating by the reading device. When RST is driven high, bit 0 is present on the C_{OUT} pin, which is fed back to the input D pin through the isolation resistor. When the CLK input transitions low to high, bit 0 is loaded into the first position of the I/O shift register and bit 1 becomes present on C_{OUT} and D of the next device. After 16 bits (or 16 times the number of DS1801s in the daisy chain), the data has shifted completely around and back to its original position. When RST transitions to the low state to end data transfer, the value (the same as before the read occurred) is loaded into wiper-0 and wiper-1.

CASCADING MULTIPLE DEVICES Figure 4



Zero-Crossing Detection

The DS1801 provides a zero-crossing detection capability that minimizes any audible noise that may result from sizable discrete wiper transitions when using the part in audio applications. The zero-crossing detect feature allows independent wiper changes only when the two terminals of the potentiometer have equal potentials and are within a 50 ms time window from the fall of the RST signal. If at 50 ms the DS1801 has not detected a zero-crossing, the wiper position of the potentiometer(s) will change regardless of the state of the input signal. Zero-crossing detection is activated when the ZCEN input level is in a low-state. When high, the ZCEN input deactivates both the 50 ms time requirement and zero detection crossing.

TYPICAL SUPPLY CURRENT VS. SERIAL CLOCK RATE Figure 5

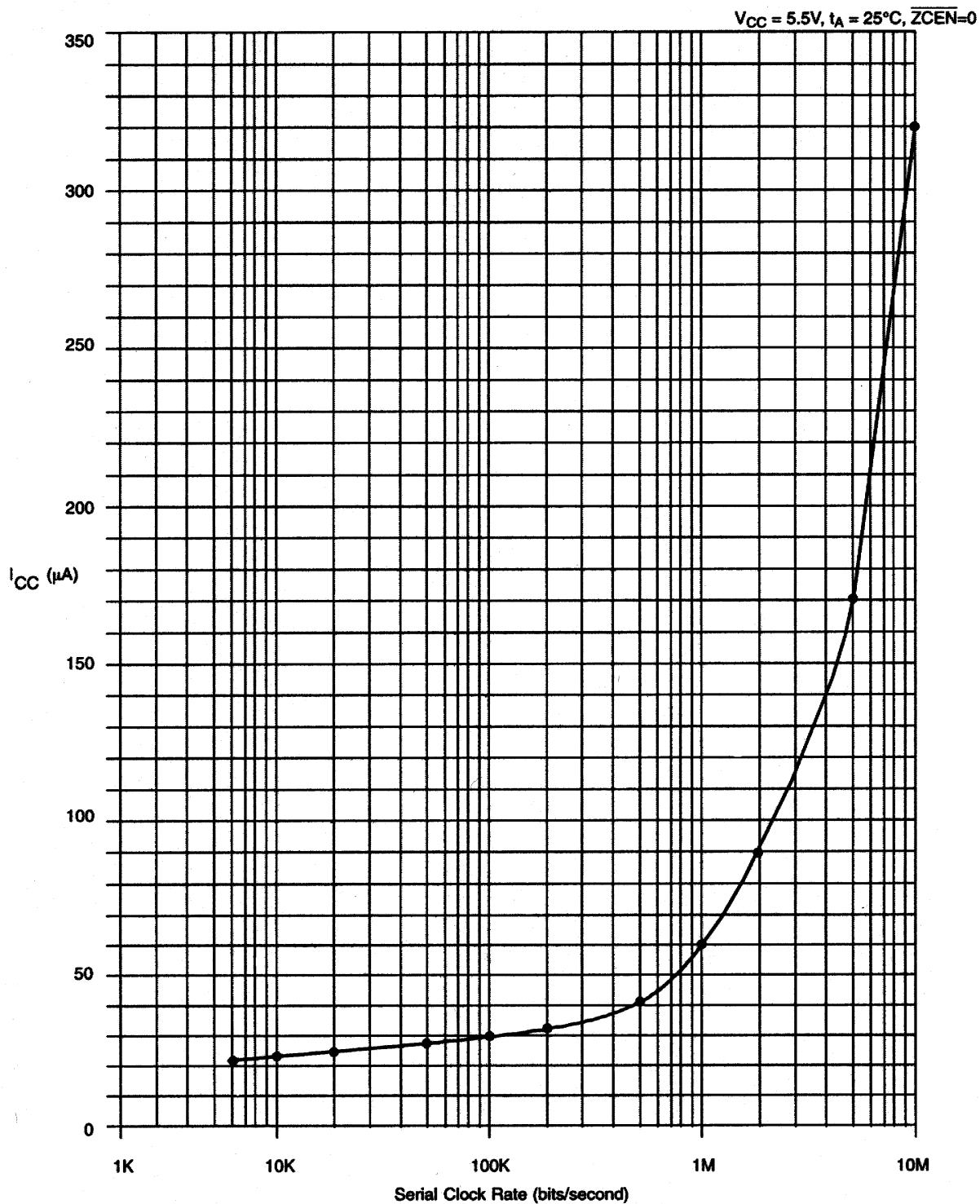

ABSOLUTE MAXIMUM RATINGS*

Voltage on Any Pin Relative to Ground	-0.7V to +7.0V
Operating Temperature	-40° to +85°C; industrial
Storage Temperature	-55°C to +125°C
Soldering Temperature	260°C for 10 seconds

* This is a stress rating only and functional operation of the device at these or any other conditions above those indicated in the operation sections of this specification is not implied. Exposure to absolute maximum rating conditions for extended periods of time may affect reliability.

RECOMMENDED DC OPERATING CONDITIONS (-40°C to +85°C)

PARAMETER	SYMBOL	MIN	TYP	MAX	UNITS	NOTES
Supply Voltage	V _{CC}	+2.7		5.5	V	
Input Logic 1	V _{IH}	+2.0		V _{CC} +0.5	V	1,2
Input Logic 0	V _{IL}	-0.5		+0.8	V	1,2
Resistor Inputs	L,H,W	GND-0.5		V _{CC} +0.5	V	2
Analog Ground	AGND	GND-0.5		GND+0.5	V	10

DC ELECTRICAL CHARACTERISTICS (-40°C to +85°C; V_{CC}=2.7V to 5.5V)

PARAMETER	SYMBOL	MIN	TYP	MAX	UNITS	NOTES
Supply Current	I _{CC}				μA	9
Input Leakage	I _{LI}	-1		+1	μA	
Wiper Resistance	R _W		400		Ω	
Wiper Current	I _W			1	mA	
Logic 1 Output Current @2.4V	I _{OH}			-0.4	mA	2
Logic 0 Output Current @0.4V	I _{OL}	2			mA	2
Standby Current: 3 Volts			12	30	μA	
5 Volts			20	50	μA	11

ANALOG RESISTOR CHARACTERISTICS (-40°C to +85°C; $V_{CC}=2.7V$ to 5.5V)

PARAMETER	SYMBOL	MIN	TYP	MAX	UNITS	NOTES
End to End Resistor Tolerance		-20		+20	%	13
Absolute Tolerance		-1		+1	dB	8
Interchannel Matching		-0.5		+0.5	dB	4
Tap-to-Tap Tolerance		-0.25		+0.25	dB	5,12
-3 dB Cutoff Frequency	f_{CUTOFF}		700		kHz	
Temperature Coefficient			750		ppm/°C	
Total Harmonic Distortion ($V_{IN}=1V_{RMS}$, 1 kHz, Tap= -6 dB)	THD		0.002		%	12
Output Noise (20 Hz to 20 kHz, Grounded Input, Tap= -6 dB)			2.2		μV_{RMS}	
Digital Feedthrough (20 Hz to 20 kHz, Tap= -6 dB)			-90		dB	12
Interchannel Isolation (20 Hz to 20kHz, Tap= -6 dB)			-100		dB	12
Mute Control Active	Mute		-90		dB	

CAPACITANCE (-40°C to +85°C; $V_{CC}=2.7V$ to 5.5V)

PARAMETER	SYMBOL	MIN	TYP	MAX	UNITS	NOTES
Input Capacitance	C_{IN}			5	pF	6
Output Capacitance	C_{OUT}			7	pF	6

AC ELECTRICAL CHARACTERISTICS (-40°C to +85°C; $V_{CC}=2.7V$ to 5.5V)

PARAMETER	SYMBOL	MIN	TYP	MAX	UNITS	NOTES
CLK Frequency	f_{CLK}	DC		10	MHz	7
Width of CLK Pulse	t_{CH}	50			ns	7
Data Setup Time	t_{DC}	30			ns	7
Data Hold Time	t_{CDH}	10			ns	7
Propagation Delay Time Low to High Level Clock to Output	t_{PLH}			50	ns	7
Propagation Delay Time Low to High Level	t_{PLH}			50	ns	7
\overline{RST} High to Clock Input High	t_{CC}	50			ns	7
\overline{RST} Low to Clock Input High	t_{HLT}	50			ns	7
CLK Rise Time	t_{CR}			60	ns	7
\overline{RST} Inactive	t_{RLT}	200			ns	7

NOTES:

- All voltages are referenced to ground.
- Valid for $V_{CC} = 2V$ only.
- Capacitance values apply at 25°C.
- Inter-channel matching is used to determine the relative voltage difference in dB between the same tap position on each potentiometer. The DS1801 is specified for ± 0.5 dB inter-channel matching.
- Tap-to-tap tolerance is used to determine the change in voltage between successive tap positions. The DS1801 is specified for ± 0.25 dB tap-to-tap tolerance.
- Typical values are for $T_A = 25^\circ C$ and nominal supply voltage.
- See Figure 3.
- Absolute tolerance is used to determine measured wiper voltage vs. expected wiper voltage as determined by wiper position. The DS1801 is bounded by a ± 1 dB absolute tolerance.
- Maximum current specifications are based on clock rate and active zero-crossing detection. See Figure 5 for clock rate vs. current specification.
- See Figure 7.
- Standby current levels apply when all inputs are driven to appropriate supply levels.
- These parameters are characterized and not 100% tested.
- Valid at 25° C only.