

## RF Power MOSFET Transistor 5 W, 2 - 175 MHz, 28 V

Rev. V1

### Features

- N-Channel enhancement mode device
- DMOS structure
- Lower capacitances for broadband operation
- High saturated output power
- Lower noise figure than bipolar devices
- RoHS Compliant

### ABSOLUTE MAXIMUM RATINGS AT 25° C

Parameter	Symbol	Rating	Units
Drain-Source Voltage	$V_{DS}$	65	V
Gate-Source Voltage	$V_{GS}$	20	V
Drain-Source Current	$I_{DS}$	1.4	A
Power Dissipation	$P_D$	15.8	W
Junction Temperature	$T_J$	200	°C
Storage Temperature	$T_{STG}$	-55 to +150	°C
Thermal Resistance	$\theta_{JC}$	11.1	°C/W

### TYPICAL DEVICE IMPEDANCE

F (MHz)	$Z_{IN}$ ( $\Omega$ )	$Z_{LOAD}$ ( $\Omega$ )
100	15 - j121.0	57.0 + j23.0
150	39.0 - j77.0	55.0 + j23.0
175	41.0 - j38.0	56.0 + j19.0
200	34.0 - j14.0	56.0 + j20.0

$V_{DD} = 28V, I_{DQ} = 50mA, P_{OUT} = 5W$

$Z_{IN}$  is the series equivalent input impedance of the device from gate to source.

$Z_{LOAD}$  is the optimum series equivalent load impedance as measured from drain to ground.

### Package Outline

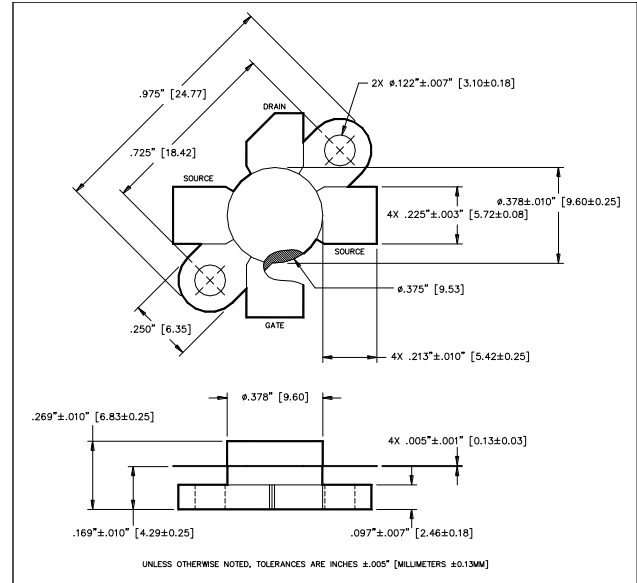

LETTER DIM	MILLIMETERS		INCHES	
	MIN	MAX	MIN	MAX
A	24.64	24.89	.970	.980
B	18.29	18.54	.720	.730
C	20.07	20.83	.790	.820
D	9.47	9.73	.373	.383
E	6.22	6.48	.245	.255
F	5.64	5.79	.222	.228
G	2.92	3.30	.115	.130
H	2.29	2.67	.090	.105
J	4.04	4.55	.159	.179
K	6.58	7.39	.259	.291
L	.10	.15	.004	.006

### ELECTRICAL CHARACTERISTICS AT 25°C

Parameter	Symbol	Min	Max	Units	Test Conditions
Drain-Source Breakdown Voltage	$BV_{DSS}$	65	-	V	$V_{GS} = 0.0 V, I_{DS} = 20.0 mA$
Drain-Source Leakage Current	$I_{DSS}$	-	1.0	mA	$V_{GS} = 28.0 V, V_{DS} = 0.0 V$
Gate-Source Leakage Current	$I_{GSS}$	-	1.0	$\mu A$	$V_{GS} = 20.0 V, V_{DS} = 0.0 V$
Gate Threshold Voltage	$V_{GS(TH)}$	2.0	6.0	V	$V_{DS} = 10.0 V, I_{DS} = 10 mA$
Forward Transconductance	$G_M$	80	-	S	$V_{DS} = 10.0 V, I_{DS} = 10 mA, \Delta V_{GS} = 1.0 V, 80 \mu s$ Pulse
Input Capacitance	$C_{ISS}$	-	7	pF	$V_{DS} = 28.0 V, F = 1.0 MHz$
Output Capacitance	$C_{OSS}$	-	5	pF	$V_{DS} = 28.0 V, F = 1.0 MHz$
Reverse Capacitance	$C_{RSS}$	-	2.4	pF	$V_{DS} = 28.0 V, F = 1.0 MHz$
Power Gain	$G_P$	11	-	dB	$V_{DD} = 28.0 V, I_{DQ} = 50 mA, P_{OUT} = 5.0 W F = 175 MHz$
Drain Efficiency	$\eta_D$	55	-	%	$V_{DD} = 28.0 V, I_{DQ} = 50 mA, P_{OUT} = 5.0 W F = 175 MHz$
Load Mismatch	VSWR-T	-	20:1	-	$V_{DD} = 28.0 V, I_{DQ} = 50 mA, P_{OUT} = 5.0 W F = 175 MHz$

M/A-COM Technology Solutions Inc. (MACOM) and its affiliates reserve the right to make changes to the product(s) or information contained herein without notice. Visit [www.macom.com](http://www.macom.com) for additional data sheets and product information.

**Typical Broadband Performance Curves**

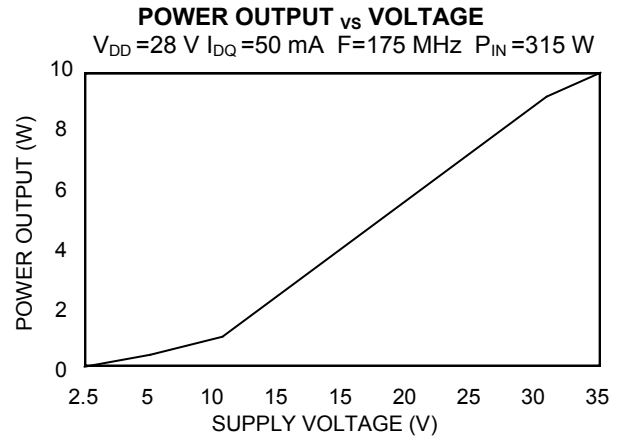
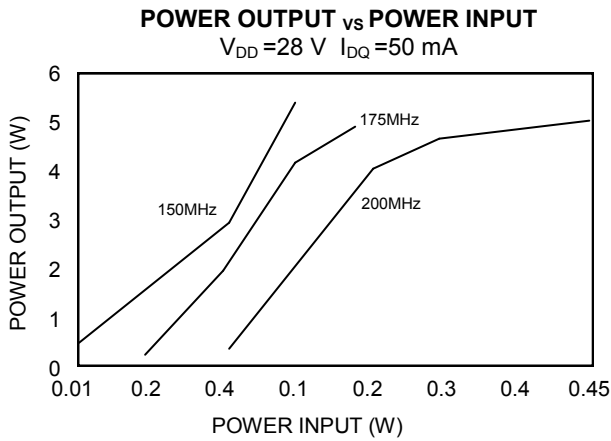
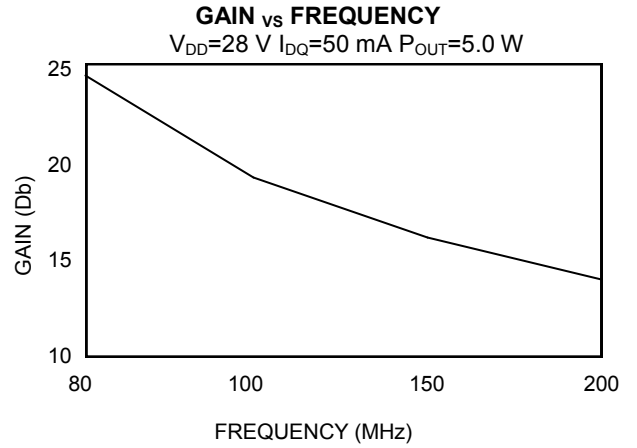
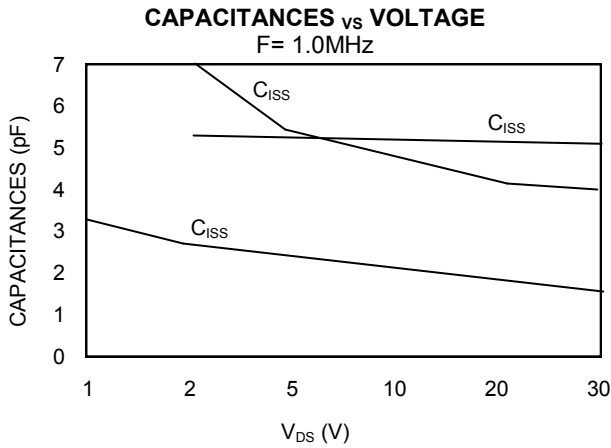

## RF Power MOSFET Transistor 5 W, 2 - 175 MHz, 28 V

Rev. V1

### TEST FIXTURE SCHEMATIC

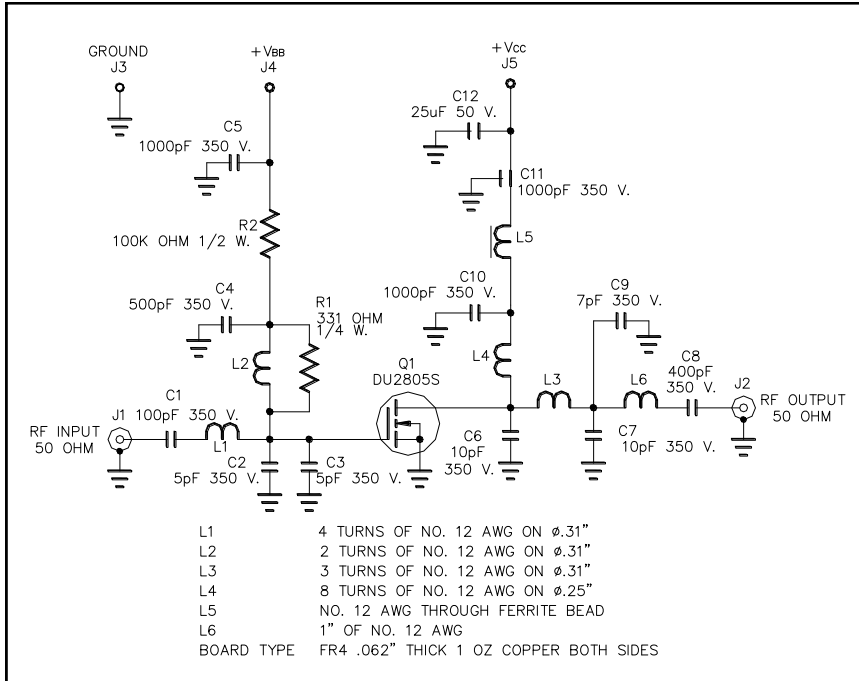

### TEST FIXTURE ASSEMBLY

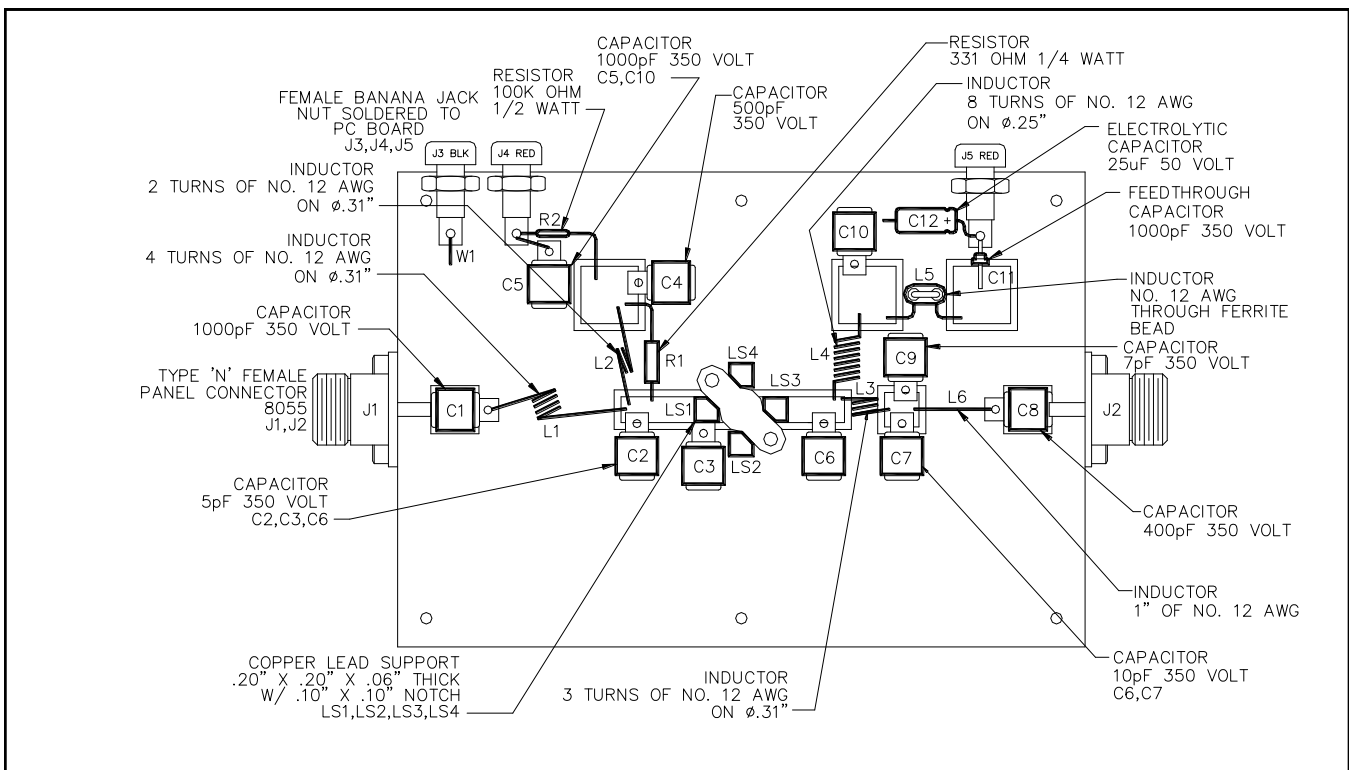

3

M/A-COM Technology Solutions Inc. (MACOM) and its affiliates reserve the right to make changes to the product(s) or information contained herein without notice. Visit [www.macom.com](http://www.macom.com) for additional data sheets and product information.

For further information and support please visit:  
<https://www.macom.com/support>