

RF Power MOSFET Transistor 60 W, 2 - 175 MHz, 28 V

Rev. V1

Features

- N-Channel enhancement mode device
- DMOS structure
- Lower capacitances for broadband operation
- High saturated output power
- Lower noise figure than bipolar devices
- RoHS Compliant

ABSOLUTE MAXIMUM RATINGS AT 25° C

Parameter	Symbol	Rating	Units
Drain-Source Voltage	V_{DS}	65	V
Gate-Source Voltage	V_{GS}	20	V
Drain-Source Current	I_{DS}	12	A
Power Dissipation	P_D	159	W
Junction Temperature	T_J	200	°C
Storage Temperature	T_{STG}	-55 to +150	°C
Thermal Resistance	θ_{JC}	1.1	°C/W

TYPICAL DEVICE IMPEDANCE

F (MHz)	Z_{IN} (Ω)	Z_{LOAD} (Ω)
30	9.0 - j4.0	6.0 + j0.0
50	6.0 - j5.8	5.0 + j2.0
100	4.0 - j4.2	4.0 + j3.0
200	1.0 - j1.0	2.0 + j1.9
$V_{DD} = 28V, I_{DQ} = 300mA, P_{OUT} = 60 W$		

Z_{IN} is the series equivalent input impedance of the device from gate to source.

Z_{LOAD} is the optimum series equivalent load impedance as measured from drain to ground.

Package Outline

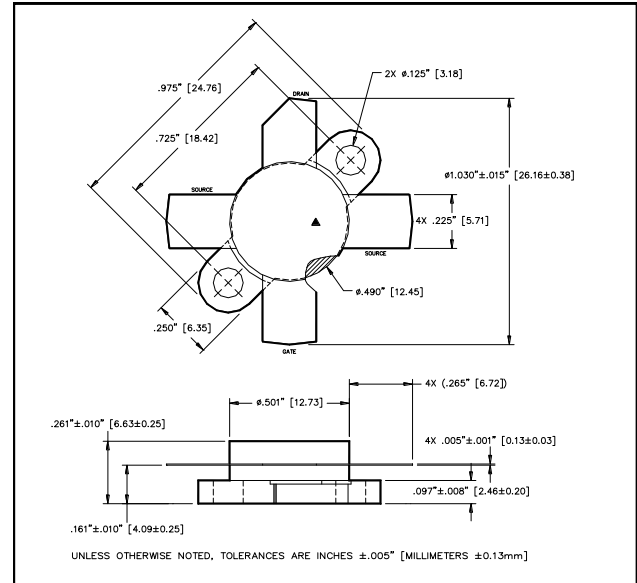

LETTER DIM	MILLIMETERS		INCHES	
	MIN	MAX	MIN	MAX
A	24.64	24.89	.970	.980
B	18.29	18.54	.720	.730
C	25.96	26.42	1.020	1.040
D	12.60	12.85	.496	.506
E	6.22	6.48	.245	.255
F	5.59	5.84	.220	.230
G	3.05	3.30	.120	.130
H	2.21	2.59	.087	.102
J	3.91	4.42	.154	.174
K	6.53	7.34	.257	.289
L	.10	.15	.004	.006

ELECTRICAL CHARACTERISTICS AT 25°C

Parameter	Symbol	Min	Max	Units	Test Conditions
Drain-Source Breakdown Voltage	BV_{DSS}	65	-	V	$V_{GS} = 0.0 V, I_{DS} = 15.0 mA$
Drain-Source Leakage Current	I_{DSS}	-	3.0	mA	$V_{GS} = 28.0 V, V_{DS} = 0.0 V$
Gate-Source Leakage Current	I_{GSS}	-	3.0	μA	$V_{GS} = 20.0 V, V_{DS} = 0.0 V$
Gate Threshold Voltage	$V_{GS(TH)}$	2.0	6.0	V	$V_{DS} = 10.0 V, I_{DS} = 300.0 mA$
Forward Transconductance	G_M	1.5	-	S	$V_{DS} = 10.0 V, I_{DS} = 3.0 A, \Delta V_{GS} = 1.0V, 80 \mu s$ Pulse
Input Capacitance	C_{ISS}	-	135	pF	$V_{DS} = 28.0 V, F = 1.0 MHz$
Output Capacitance	C_{OSS}	-	120	pF	$V_{DS} = 28.0 V, F = 1.0 MHz$
Reverse Capacitance	C_{RSS}	-	24	pF	$V_{DS} = 28.0 V, F = 1.0 MHz$
Power Gain	G_P	13	-	dB	$V_{DD} = 28.0 V, I_{DQ} = 300 mA, P_{OUT} = 60.0 W F = 175 MHz$
Drain Efficiency	η_D	60	-	%	$V_{DD} = 28.0 V, I_{DQ} = 300 mA, P_{OUT} = 60.0 W F = 175 MHz$
Load Mismatch Tolerance	VSWR-T	-	30:1	-	$V_{DD} = 28.0 V, I_{DQ} = 300 mA, P_{OUT} = 60.0 W F = 175 MHz$

M/A-COM Technology Solutions Inc. (MACOM) and its affiliates reserve the right to make changes to the product(s) or information contained herein without notice. Visit www.macom.com for additional data sheets and product information.

Typical Broadband Performance Curves

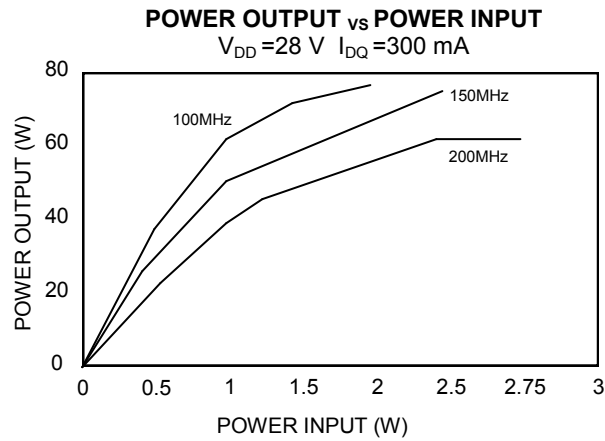
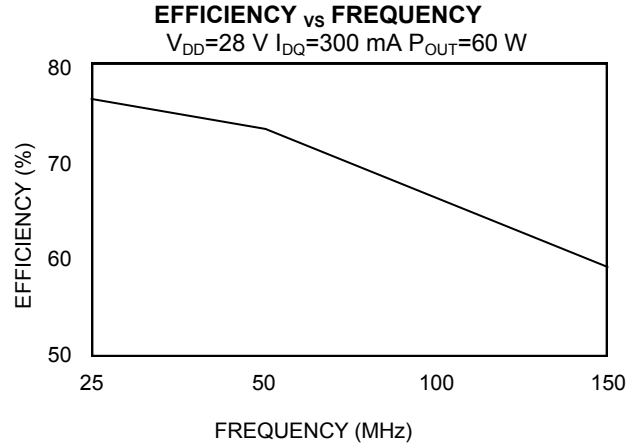
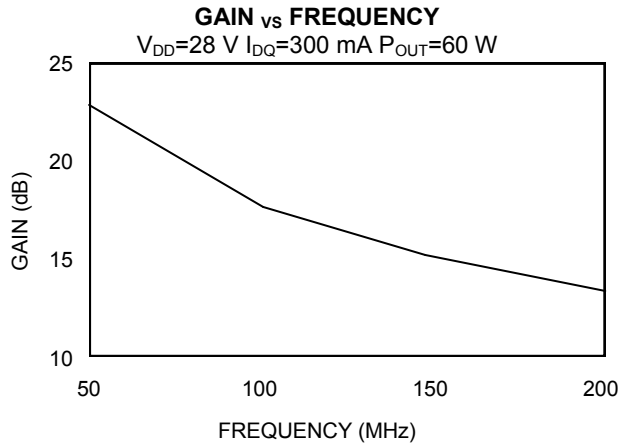

RF Power MOSFET Transistor 60 W, 2 - 175 MHz, 28 V

Rev. V1

TEST FIXTURE SCHEMATIC

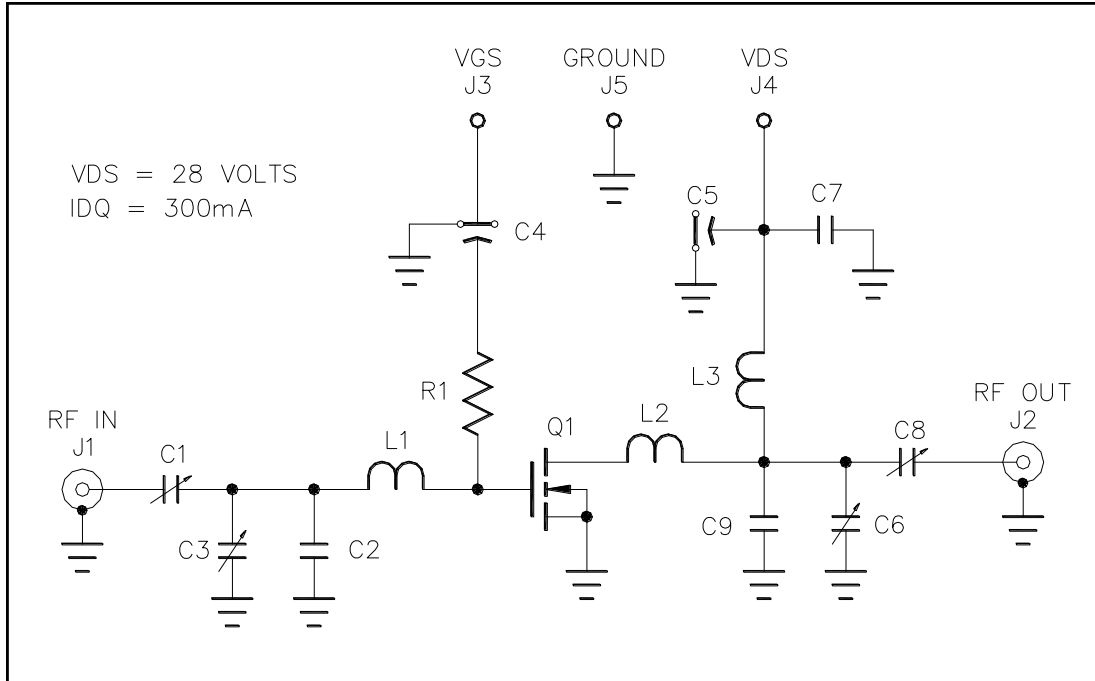

TEST FIXTURE ASSEMBLY

