

Power pins		2
Signal pins		20
Rated current	Power	500 A
	Signal	2 A
Rated voltage	Power	600 V
	Signal	100 V
Overvoltage category		4
Pollution grade		3
Temperature increase at power portion		45 C
Ambient temperature		-25 to +60 C
Allowable temp at power portion		105 C

## Receptacle

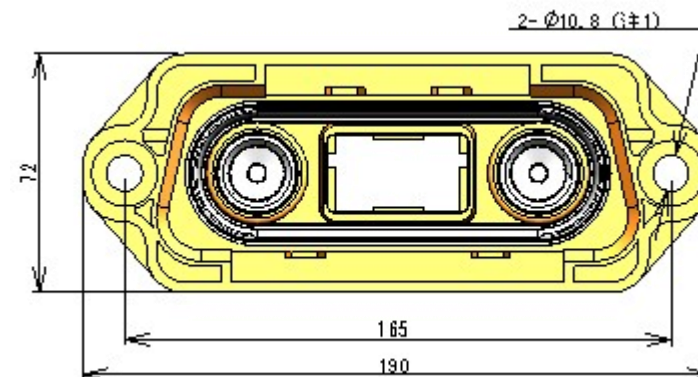

## Plug

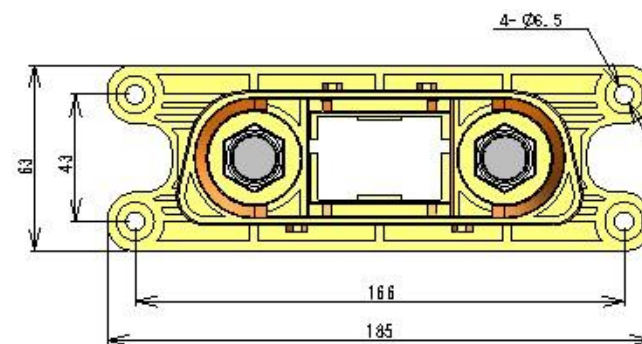

# DW1 Application Example



Technology to Inspire Innovation

Large-scale Power Storage

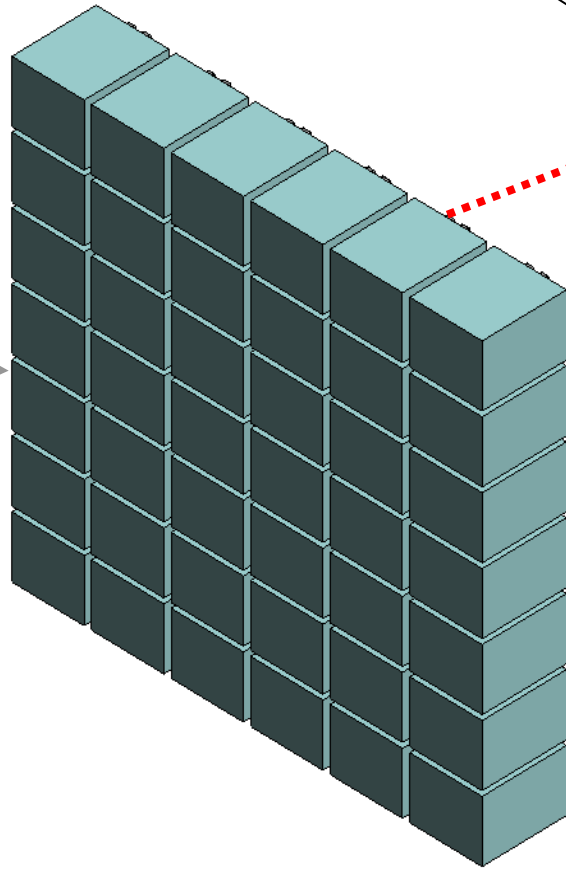
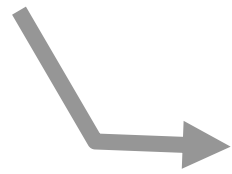

Rack and Panel

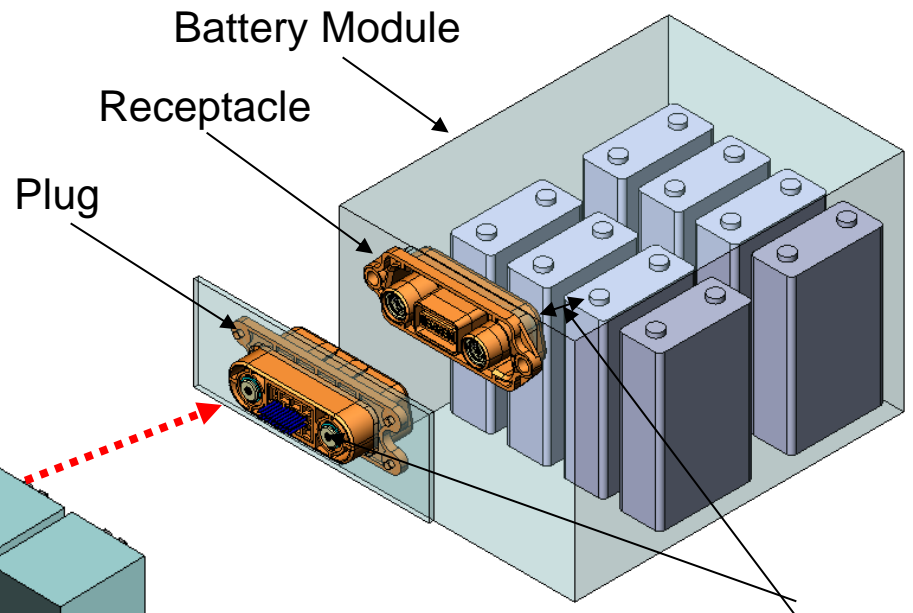

Connected by bus-bar or cable

Battery Module mounting image

# DW1 Signal Contacts

Technology to Inspire Innovation

Receptacle

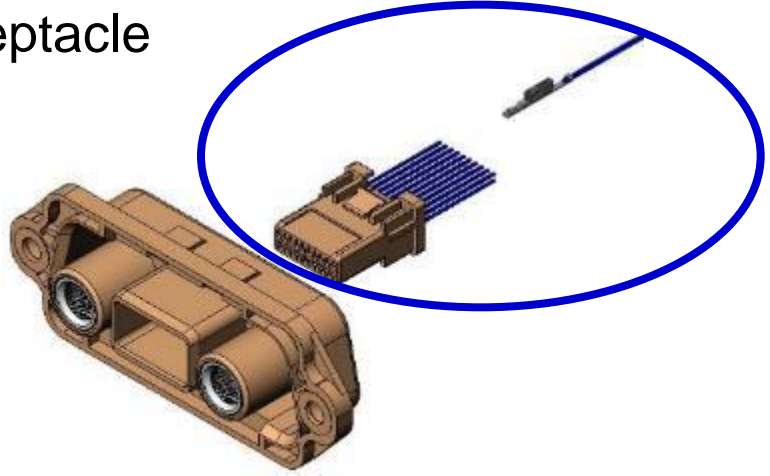

Plug

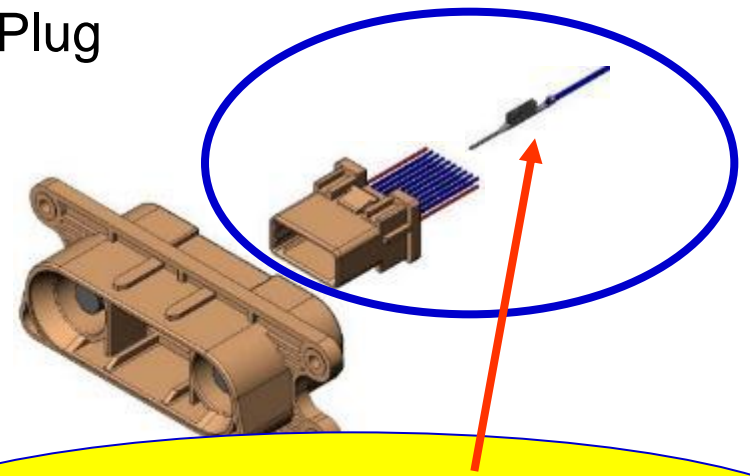

Stepped mating with a 1.5mm recessed contact line

## Box-type Contact Structure

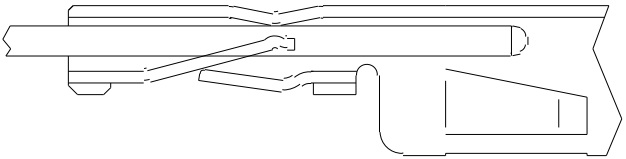

2-point contact → Steady Connection

Better than inferior bellows-type  
1 point contact → weak with and dust

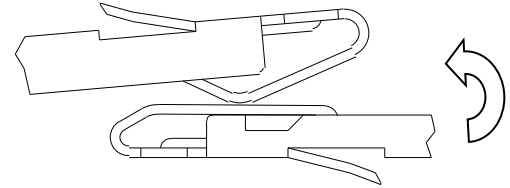

Same concept as high-reliability automotive contacts

Plug

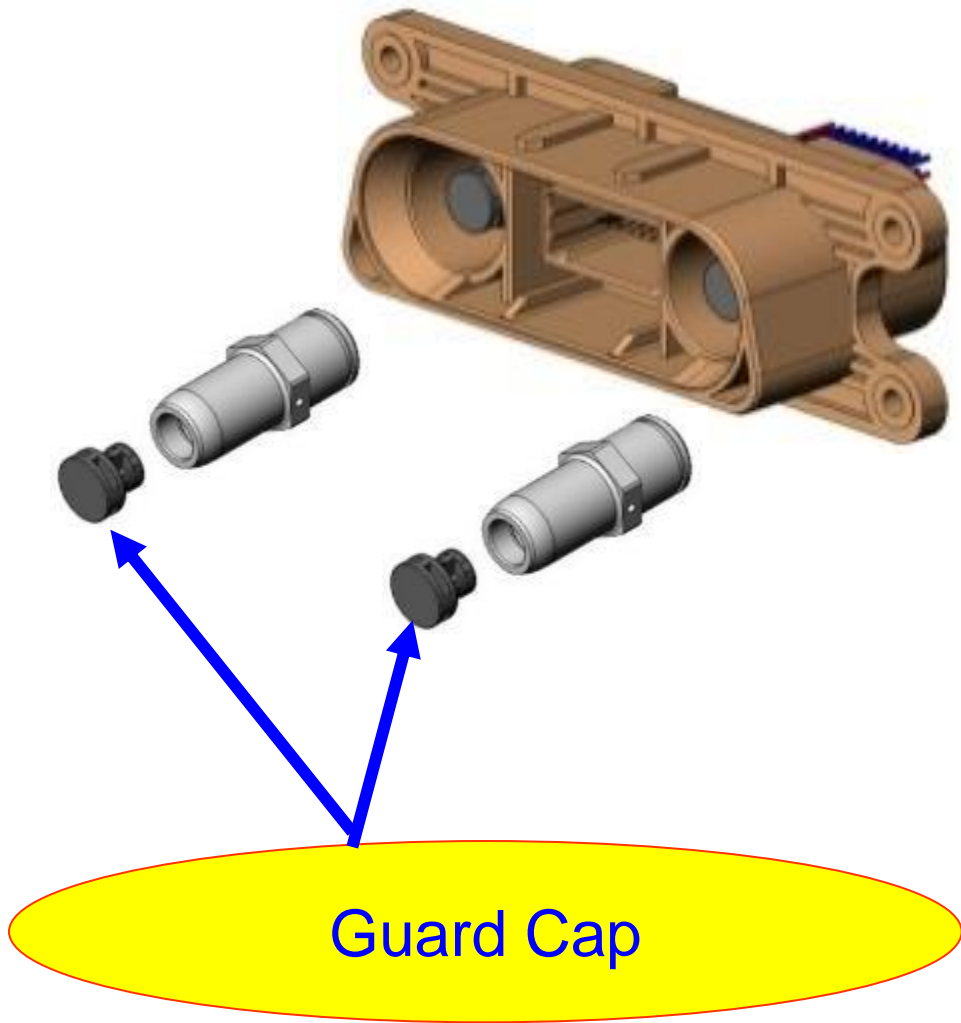

Guard Cap

Details

Guard Cap

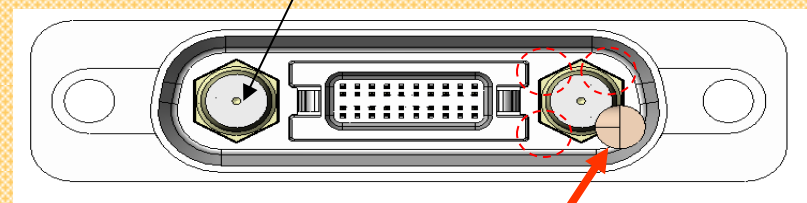

Electrical Appliance and Material Safety (J60950)

Finger test cleared ( $\phi 12\text{mm}$ )

