

Product Overview

The Qorvo® DWM3000 is a fully integrated Ultra-Wideband (UWB) transceiver module based on the Qorvo® DW3110 IC. It integrates antenna, all RF circuitry, power management and clock circuitry in one module simplifying integration. It can be used in 2-way ranging or TDoA location systems to locate assets to a precision of 10 cm and supports data rates of up to 6.8 Mbps.

The DWM3000 is designed to be compliant to the FiRa™ PHY and MAC specifications enabling interoperability with other FiRa™ compliant devices.



Functional Block Diagram

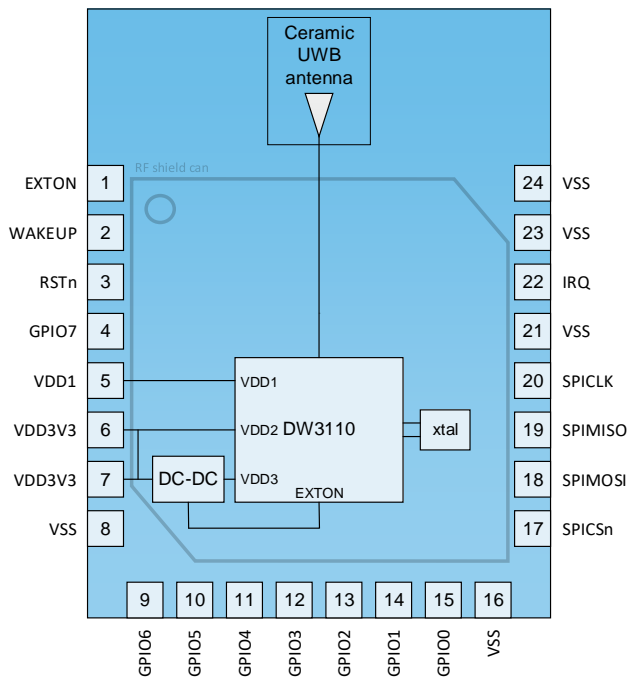

Top View

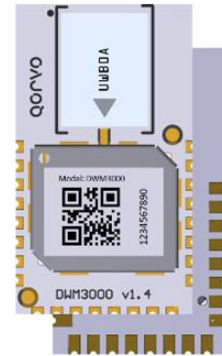

24 Pin 23 x 13 mm side castellated package

Key Features

- IEEE 802.15.4-2015 and IEEE 802.15.4z BPRF compliant
- Fully aligned with FiRa™ PHY, MAC and certification development
- Supports UWB Channels 5 (6.5 GHz) and 9 (8 GHz)
- Programmable transmitter output power
- Fully coherent receiver for maximum range and accuracy
- Designed to comply with FCC & ETSI UWB spectral masks
- Supply voltage VDD3V3: 2.5 V – 3.6 V
VDD1: 1.62 V – 3.6 V
- Low power consumption
- Data rates of 850 kbps, 6.8 Mbps
- Maximum packet length of 1023 bytes for high data throughput applications
- Integrated MAC support features
- SPI interface to host processor
- Pin and pitch compatible with the DWM1000

Applications

- Precision real time location systems (RTLs) using two-way ranging or TDoA schemes in a variety of markets.
- Location aware wireless sensor networks (WSNs)

Ordering Information

PART NUMBER	DESCRIPTION
DWM3000SB	5 pcs bag
DWM3000SQ	25 pcs bag
DWM3000SR	100 pcs on a 7" reel
DWM3000TR13	500 pcs on a 13" reel
DWM3000EVB	Evaluation board

Table of Contents

1 Overview	3	4.1 Nominal Operating Conditions.....	13
1.1 DWM3000 Functional Description	3	4.2 DC Characteristics.....	13
1.2 DWM3000 Power Up	3	4.3 Receiver AC Characteristics.....	14
1.3 SPI Host Interface.....	5	4.4 Reference Clock AC Characteristics.....	14
1.3.1 SPI Timing Parameters	5	4.4.1 Reference Frequency.....	14
1.3.2 SPI Operating Modes.....	6	4.5 Transmitter AC Characteristics.....	14
1.3.3 SPI Transaction Formatting	7	4.6 Absolute Maximum Ratings.....	15
1.4 General Purpose Input Output (GPIO).....	8	5 Antenna Performance	16
1.5 Always-On (AON) Memory	8	6 Application Information	19
1.6 One-Time Programmable (OTP) Memory	8	6.1 Application Board Layout Guidelines	19
1.7 Interrupts and Device Status	8	6.2 Application Circuit Diagram	20
1.8 MAC.....	8	6.3 GPIO and SPI I/O Internal Pull Up / Down	20
2 DWM3000 Calibration	9	7 Package Information	21
2.1 Crystal Oscillator Trim.....	9	7.1 Module Drawings	21
2.2 Transmitter Calibration.....	9	7.2 Module Land Pattern.....	22
2.3 Antenna Delay Calibration.....	9	7.3 Module Marking Information	22
3 DWM3000 Pin Connections	10	7.4 Module Solder Profile.....	23
3.1 Pin Numbering.....	10	7.5 Tape and Reel Information.....	24
3.2 Pin Descriptions.....	11	8 Glossary	25
4 Electrical Specifications	13	9 Revision History	26
		10 Further Information	26

List of Figures

Figure 1: Timing diagram for cold start POR.....	4	Figure 10: Application Board Keep-Out Areas	19
Figure 2: Timing diagram for warm start	4	Figure 11: Example DWM3000 Application Circuit	20
Figure 3: SPI Timing Diagram.....	5	Figure 12: SPI and GPIO Pull Up / Down	20
Figure 4: SPI Detailed Timing Diagram.....	5	Figure 13: Module Package Size (mm)	21
Figure 5: DW3000 SPIPHA=0 Transfer Protocol	6	Figure 14: Module Land Pattern (units: mm)	22
Figure 6: DW3000 SPIPHA=1 Transfer Protocol	7	Figure 15: Module Marking Information.....	22
Figure 7: SPI Command Formatting	7	Figure 16: DWM3000 Module Solder Profile	23
Figure 8: DWM3000 Pin Diagram	10	Figure 17: Module Carrier Dimension (mm).....	24
Figure 9: Carrier Board Dimensions and Radiation Pattern Planes	16	Figure 18: Module Tape Carrier Dimension (mm)	24

List of Tables

Table 1: SPI Timing Parameters	6	Table 8: DWM3000 Transmitter AC Characteristics	14
Table 2: DWM3000 Pin Functions	11	Table 9: DWM3000 Absolute Maximum Ratings	15
Table 3: Explanation of Abbreviations	12	Table 10 Antenna Radiation Patterns - Channel 5	17
Table 4: DWM3000 Operating Conditions	13	Table 11 Antenna Radiation Patterns - Channel 9	18
Table 5: DWM3000 DC Characteristics	13	Table 12: Glossary of Terms	25
Table 6: DWM3000 Receiver AC Characteristics	14		
Table 7: Reference Clock AC Characteristics.....	14		

1 Overview

The DWM3000 module is an IEEE 802.15.4-2011 and IEEE 802.15.4z (BPRF mode) UWB implementation. RF components, Qorvo DW3110 UWB transceiver, and other components reside on-module. DWM3000 enables cost effective and reduced complexity integration of UWB communications and ranging features, greatly accelerating design implementation.

1.1 DWM3000 Functional Description

The DW3110 on-board the DWM3000 is a fully integrated low-power, single chip CMOS RF transceiver IC. The DWM3000 module requires no RF design as the antenna and associated analog and RF components are on the module.

The module contains an on-board 38.4 MHz reference crystal. The crystal has been trimmed in production to reduce the initial frequency error to approximately 2 ppm, using the DW3110 IC's internal on-chip crystal trimming circuit, see section 2.1.

Always-On (AON) memory can be used to retain DWM3000 configuration data during the lowest power operational states when the on-chip voltage regulators are disabled. This data is uploaded and downloaded automatically. Use of DWM3000 AON memory is configurable.

The on-chip voltage and temperature monitors allow the host to read the voltage on the VDD1 pin and the internal die temperature information from the DW3110.

See the DW3000 datasheet for more detailed information on device functionality, electrical specifications, and typical performance.

1.2 DWM3000 Power Up

DWM3000 is designed such that it can be powered in a number of different configurations depending on the application. These options are described below. Figure 1 shows the power up sequence when external power sources are applied. The power supply design should ensure that VDD2a/b and VDD3 are stable less than 10 ms after VDD1 (3.3 V) comes up, otherwise a device reset is required.

When the external power source is applied to the DWM3000 for the first time (cold power up), the internal Power On Reset (POR) circuit compares the externally applied supply voltage (VDD1) to an internal power-on threshold (approximately 1.5 V), and once this threshold is passed, the AON block is released from reset and the external device enable pin EXTON is asserted.

Then the VDD2a/b and VDD3 supplies are monitored and once they are above the required voltage as specified in the datasheet (2.2 V and 1.4 V respectively), the fast RC oscillator (FAST_RC) and crystal (XTAL Oscillator) will come on within 500 μ s and 1 ms respectively.

The DWM3000 digital core will be held in reset until the crystal oscillator is stable. Once the digital reset is de-asserted the digital core wakes up and enters the INIT_RC state, (see Figure 1 and Figure 2). Then once the configurations stored in AON and OTP have been restored (into the configuration registers) the device will enter IDLE_RC. Then the host can set the AINIT2IDLE configuration bit in SEQ_CTRL and the IC will enable the CLKPLL and wait for it to lock before entering the IDLE_PLL state.

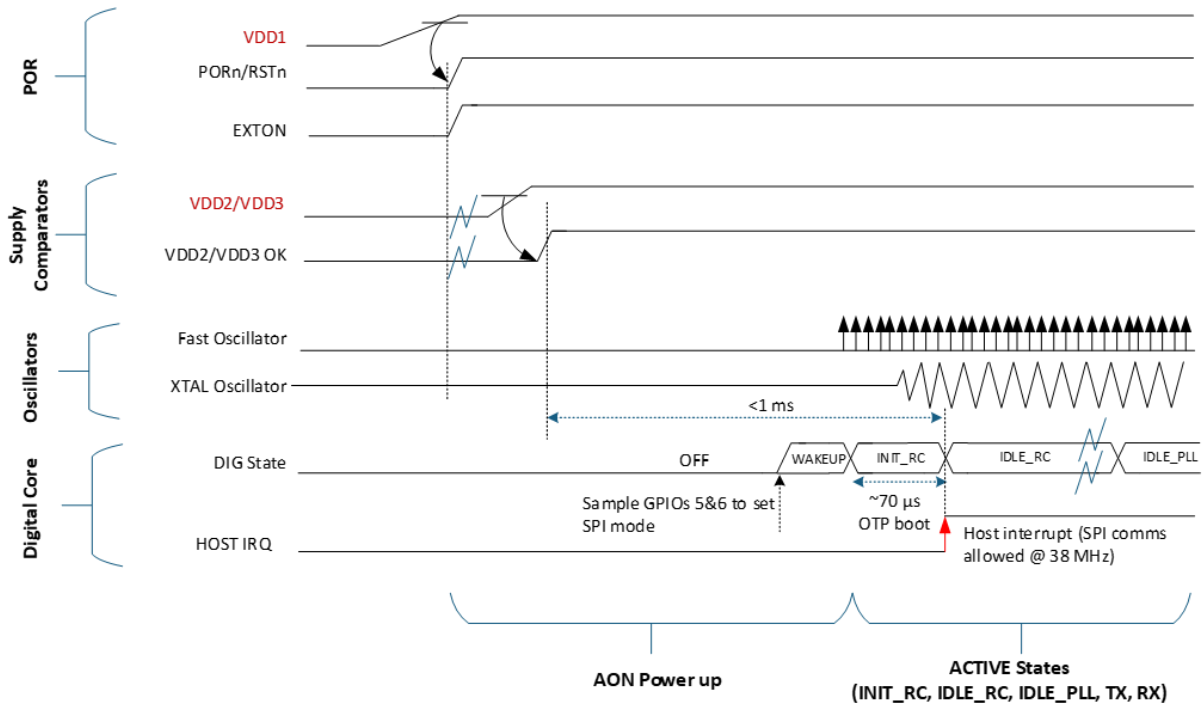

Figure 1: Timing diagram for cold start POR

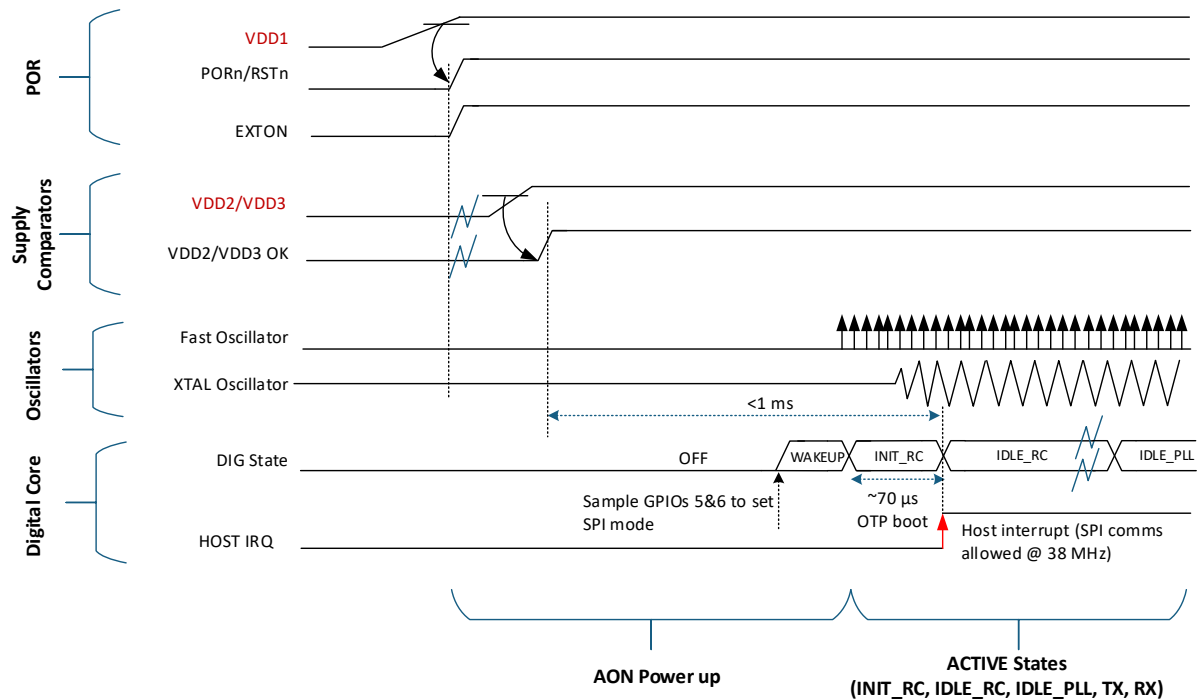

Figure 2: Timing diagram for warm start

1.3 SPI Host Interface

The host interface to DWM3000 is a 4-wire SPI-compatible slave. The assertion of SPICSn low by the SPI master indicates the beginning of a transaction.

The SPI interface is used to read and write registers in the DW3110 device. All data and address transfers on the SPI are most significant bit first. All address bytes are transmitted with MSB first, and all data is transmitted commencing with lowest addressed byte.

- Assertion low of SPICSn initializes transaction.
- De-assertion high of SPICSn ends the SPI transaction.
- The device supports direct and per-byte sub-addressing access to the full register space.
- Efficient block data reading / writing is allowed. Continuous, long transactions can be carried out while the addressed location is auto incremented on the DW3110 side.

The SPIMISO I/O is required to go open-drain when SPICSn is de-asserted, to allow interoperation with other slaves on the SPI bus. SPI daisy chaining is not supported. This is the mode where the MISO, MOSI lines are passed through a device when it is not chip selected.

1.3.1 SPI Timing Parameters

The SPI slave complies with the Motorola SPI protocol within the constraints of the timing parameters listed in Table 1 and illustrated in Figure 3 and Figure 4.

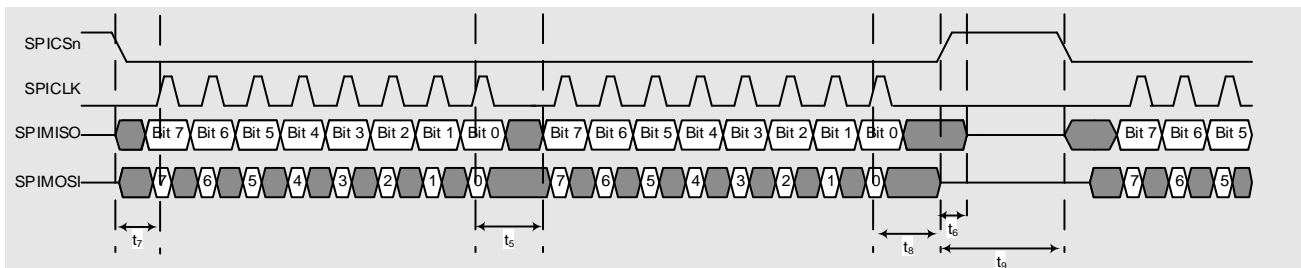

Figure 3: SPI Timing Diagram

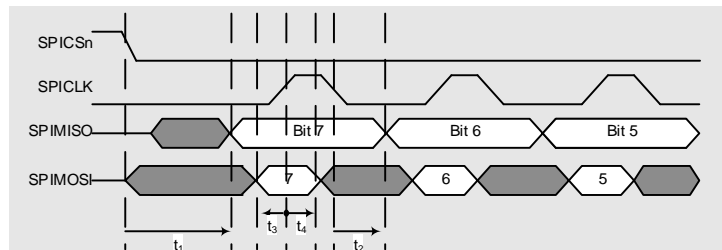

Figure 4: SPI Detailed Timing Diagram

Table 1: SPI Timing Parameters

Parameter	Min.	Typ.	Max.	Unit	Description
t ₁	3			ns	SPI select asserted low to valid slave output data.
t ₂			3	ns	SPICLK low to valid slave output data.
t ₃	14			ns	Master data setup time.
t ₄	2			ns	Master data hold time.
t ₅	27			ns	LSB last byte to MSB next byte.
t ₆			3	ns	SPICSn de-asserted high to MISO tristate.
t ₇	14			ns	Start time; time from select asserted to first SPICLK.
t ₈	24			ns	Last SPICLK to SPICSn de-asserted.
t ₉	24			ns	Idle time between consecutive accesses.
t ₁₀			38	MHz	SPI CLK Fmax @1.8 V VDD1, 25C, SPI mode 0.

1.3.2 SPI Operating Modes

Both clock polarities (SPIPOL=0/1) and phases (SPIPHA=0/1) are supported, as defined in the Motorola SPI protocol. The DW3110 transfer protocols for each SPIPOL and SPIPHA setting are given in Figure 5 and Figure 6.

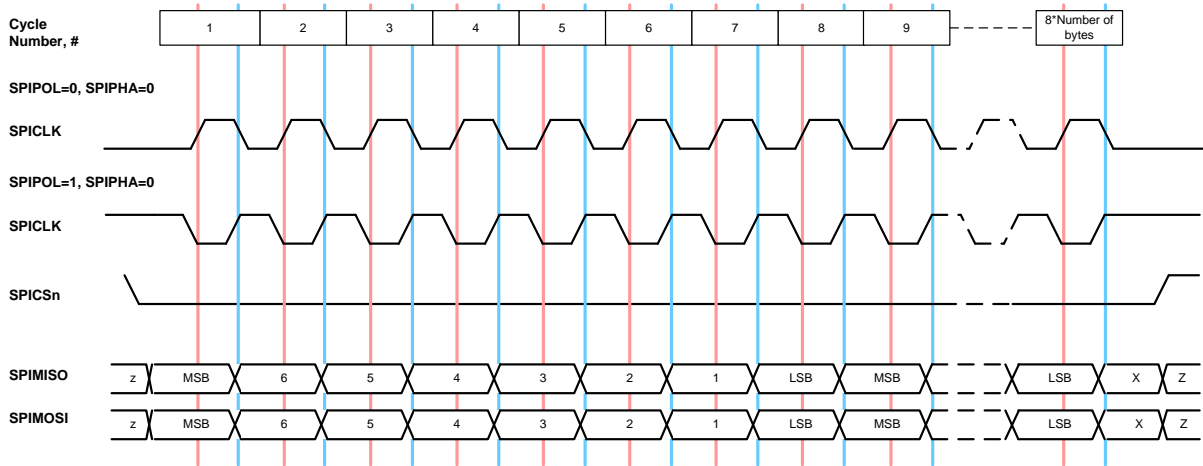

Figure 5: DW3000 SPIPHA=0 Transfer Protocol

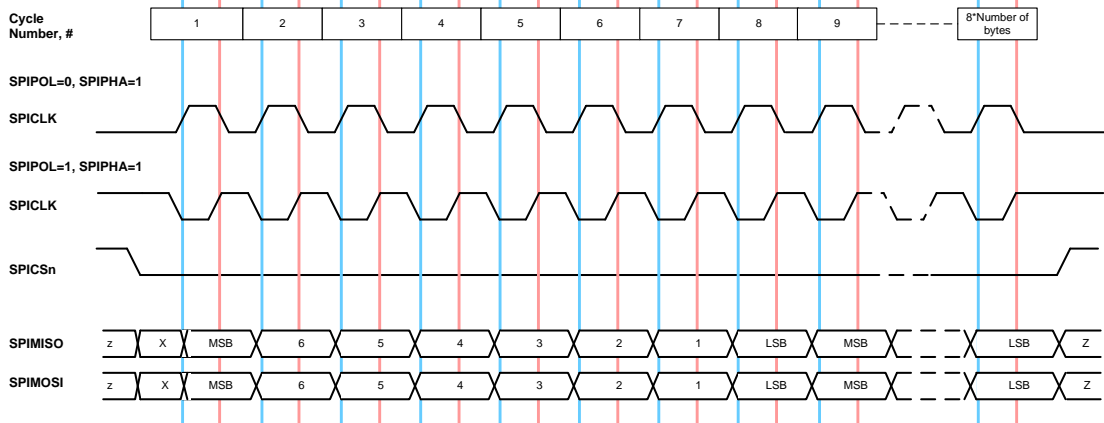

Figure 6: DW3000 SPIPHA=1 Transfer Protocol

1.3.3 SPI Transaction Formatting

The SPI command structure allows for 4 different types of SPI command:

1. Fast, single byte commands. Up to 32 unique commands such as “TX now”, “TX/RX Off”.
2. Fast addressed mode. Allowing for read and write addressing to 32 master addresses. This command structure is padded by a trailing bit to allow the SPI address decoder time to fetch any read data. The length of the read is determined by the length of the SPI transaction.
3. Full addressed mode. Allowing for read and write addressing to 32 master addresses and up to 128-byte offset addressing. This command structure is padded by a trailing bit to allow the SPI address decoder time to fetch any read data. The length of the read or write is determined by the length of the SPI transaction.
4. Masked write transaction. These are intended to simplify read-modify-write operations by allowing the host to write to an address and apply a set, clear or toggle mask to 1, 2, or 4 bytes. The SPI command decoder then carries out the required read-modify-write instructions internally.

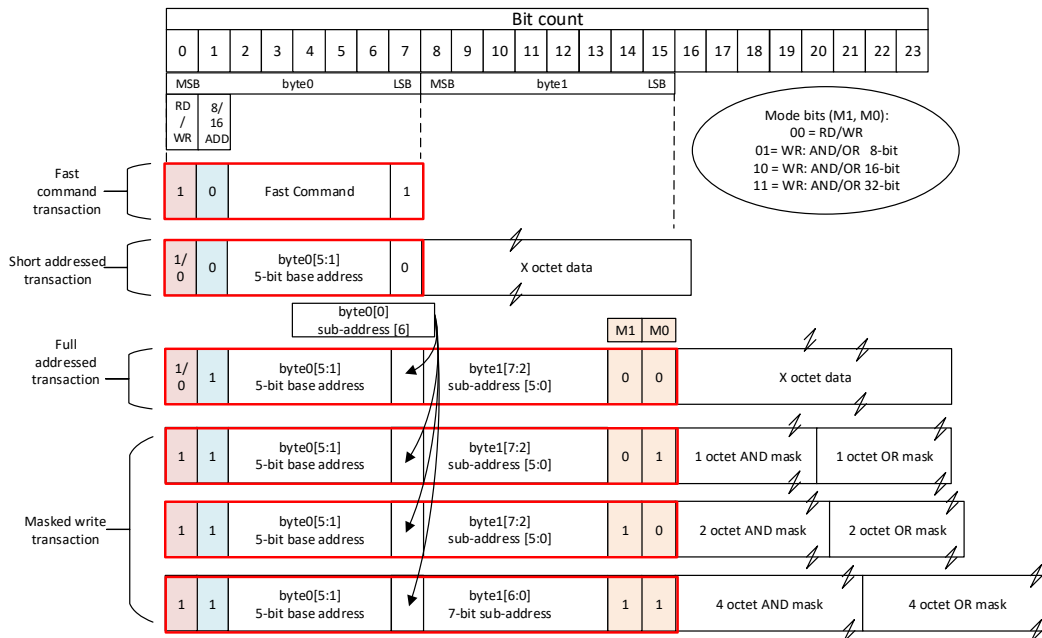

Figure 7: SPI Command Formatting



1.4 General Purpose Input Output (GPIO)

The DWM3000 provides 8 configurable pins.

On reset, all GPIO pins default to input. GPIO inputs, when appropriately configured, are capable of generating interrupts to the host processor via the IRQ signal.

See DW3000 datasheet and DW3000 user manual for full details of the configuration and use of the GPIO lines.

1.5 Always-On (AON) Memory

Configuration retention in lowest power states is enabled in DWM3000 by provision of an Always-On (AON) memory array with a separate power supply, VDD1. The DWM3000 may be configured to upload its configuration to AON before entering a low-power state and to download the configuration when waking up from the low-power state.

1.6 One-Time Programmable (OTP) Memory

The DWM3000 contains a 128x32-bit user programmable OTP memory that is used to store per chip calibration information.

1.7 Interrupts and Device Status

DWM3000 has a number of interrupt events that can be configured to drive the IRQ output pin. The default IRQ pin polarity is active high. A number of status registers are provided in the system to monitor and report data of interest. See DW3000 user manual for a full description of system interrupts and their configuration and of status registers.

1.8 MAC

A number of MAC features are implemented including CRC generation, CRC checking and receive frame filtering. See the DW3000 datasheet and DW3000 user manual for full details.

2 DWM3000 Calibration

Depending on the end-use applications and the system design, DWM3000 settings may need to be tuned. To help with this tuning a number of built-in functions such as continuous wave TX and continuous frame transmission can be enabled. See the DW3000 user manual for further details.

The DWM3000 has crystal oscillator trimmed during module production but no transmit power or antenna delay calibration.

2.1 Crystal Oscillator Trim

DWM3000 modules are calibrated at production at room temperature to minimise initial frequency error to reduce carrier frequency offset between modules and thus improve receiver sensitivity. The calibration carried out at module production will trim the initial frequency offset to less than 2 ppm, typically.

2.2 Transmitter Calibration

In order to maximize range, DWM3000 transmit power spectral density (PSD) should be set to the maximum allowable for the geographic region in which it will be used. For most regions this is -41.3 dBm/ MHz.

As the module contains an integrated antenna, the transmit power can only be measured over the air. The Effective Isotropic Radiated Power (EIRP) must be measured, and the power level adjusted to ensure compliance with applicable regulations.

The DWM3000 provides the facility to adjust the transmit power in coarse and fine steps; 2 dB and 0.5 dB nominally. It also provides the ability to adjust the spectral bandwidth. These adjustments can be used to maximize transmit power whilst meeting regulatory spectral mask.

If required, transmit calibration should be carried out on a per DWM3000 module basis, see DW3000 user manual for full details.

2.3 Antenna Delay Calibration

In order to measure range accurately, precise calculation of timestamps is required. To do this the antenna delay must be known. The DWM3000 allows this delay to be calibrated and provides the facility to compensate for delays introduced by PCB, external components, antenna and internal DWM3000 delays.

To calibrate the antenna delay, range is measured at a known distance using two DWM3000 systems. Antenna delay is adjusted until the known distance and reported range agree. The antenna delay can be stored in OTP memory.

Antenna delay calibration must be carried out as a once-off measurement for each DWM3000 design implementation. If required, for greater accuracy, antenna delay calibration should be carried out on a per DWM3000 module basis, see DW3000 user manual for full details.

3 DWM3000 Pin Connections

3.1 Pin Numbering

DWM3000 module pin assignments are as follows (viewed from top):

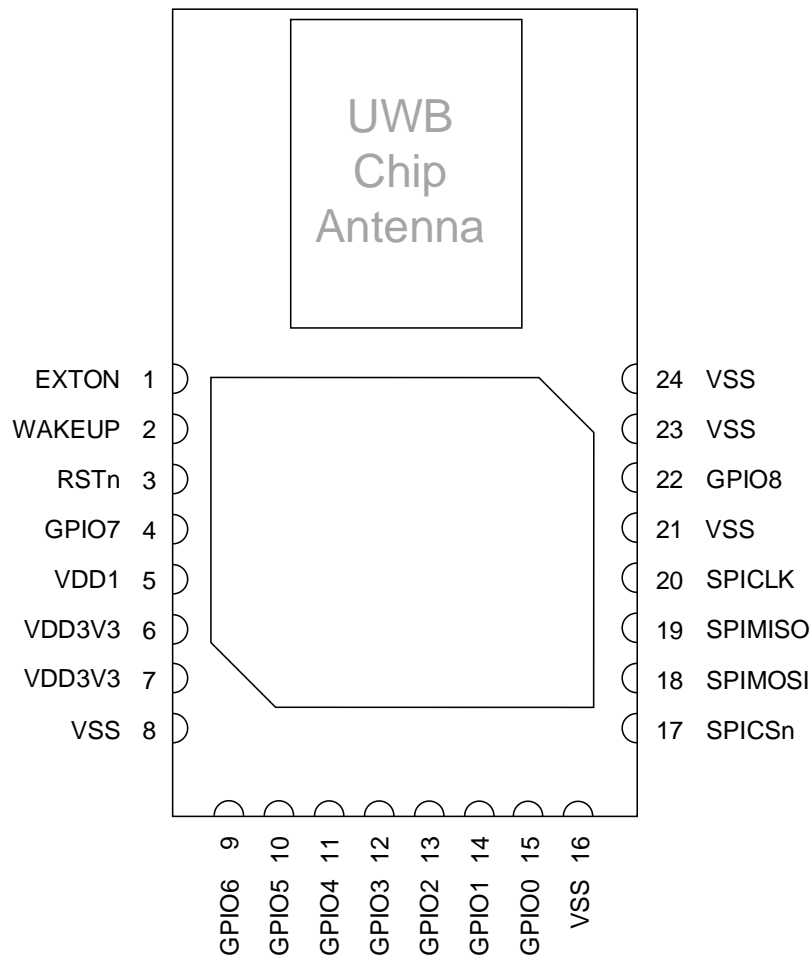

Figure 8: DWM3000 Pin Diagram

3.2 Pin Descriptions

Table 2: DWM3000 Pin Functions

Signal Name	Pin	I/O (Default)	Description
Digital Interface			
SPICLK	20	DI	SPI clock
SPIMISO	19	DO (O-L)	SPI data output.
SPIMOSI	18	DI	SPI data input.
SPICSn	17	DI	SPI chip select. This is an active low enable input. The high-to-low transition on SPICSn signals the start of a new SPI transaction. SPICSn can also act as a wake-up signal to bring DW3110 out of either SLEEP or DEEPSLEEP states.
WAKEUP	2	DIO	When asserted into its active high state, the WAKEUP pin brings the DW3110 out of SLEEP or DEEPSLEEP states into operational mode. If unused, this pin can be tied to ground.
EXTON	1	DO (O-L)	External device enable. Asserted during wake-up process and held active until device enters sleep mode. Can be used to control external DC-DC converters or other circuits that are not required when the device is in sleep mode so as to minimize power consumption.
GPIO8 / IRQ	22	DIO (O-L)	Interrupt Request output from the DWM3000 to the host processor. By default, IRQ is an active-high output but may be configured to be active low if required. For correct operation in SLEEP and DEEPSLEEP modes it should be configured for active high operation. This pin will float in SLEEP and DEEPSLEEP states and may cause spurious interrupts unless pulled low externally (100 kΩ recommended). When the IRQ functionality is not being used the pin may be reconfigured as a general purpose I/O line, GPIO8.
GPIO7 / SYNC	4	DIO (I)	Defaults to operate as a SYNC input. This pin may be reconfigured as a general purpose I/O pin under software control.
GPIO6 / EXTRXE / SPIPHA	9	DIO (I)	General purpose I/O pin. On power-up it acts as the SPIPHA (SPI phase selection) pin for configuring the SPI mode of operation. After power-up, the pin will default to a General Purpose I/O pin. On engineering samples E1.0 GPIO6 is on pin 10.
GPIO5 / EXTTXE / SPIPOL	10	DIO (I)	General purpose I/O pin. On power-up it acts as the SPIPOL (SPI polarity selection) pin for configuring the SPI operation mode. After power-up, the pin will default to a General Purpose I/O pin. On engineering samples E1.0 GPIO5 is on pin 9.
GPIO4	11	DIO (I)	General purpose I/O pin.
GPIO3 / TXLED	12	DIO (I)	General purpose I/O pin. It may be configured for use as a TXLED driving pin that can be used to light a LED following a transmission.
GPIO2 / RXLED	13	DIO (I)	General purpose I/O pin. It may be configured for use as a RXLED driving pin that can be used to light a LED during receive mode.



Signal Name	Pin	I/O (Default)	Description
GPIO1 / SFDLED	14	DIO (I)	General purpose I/O pin. It may be configured for use as a SFDLED driving pin that can be used to light a LED when SFD (Start Frame Delimiter) is found by the receiver.
GPIO0 / RXOKLED	15	DIO (I)	General purpose I/O pin. It may be configured for use as a RXOKLED driving pin that can be used to light a LED on reception of a good frame.
RSTn	3	DIO (O-H)	Reset pin. Active Low Output. May be pulled low by external open drain driver to reset the DW3000.
Power Supplies			
VDD1	5	P	External supply for the Always-On (AON) portion of the chip.
VDD3V3	6,7	P	3 V supply pins.
Ground			
GND	8,16, 21,23,24	G	Common ground.

Table 3: Explanation of Abbreviations

Abbreviation	Explanation
I	Input
IO	Input / Output
O	Output
G	Ground
P	Power Supply
PD	Power Decoupling
O-L	Defaults to output, low level after reset
O-H	Defaults to output, high level after reset
I	Defaults to input.

Note: Any signal with the suffix 'n' indicates an active low signal.

4 Electrical Specifications

4.1 Nominal Operating Conditions

Table 4: DWM3000 Operating Conditions

Parameter	Min.	Typ.	Max.	Units	Condition / Note
Operating temperature	-40		+85	°C	
Supply voltage VDD1	1.62		3.6	V	
Supply voltage VDD3V3	2.5		3.6	V	
Voltage on digital pins			3.6	V	

Note: Unit operation is guaranteed by design when operating within these ranges

4.2 DC Characteristics

T_{amb} = 25 °C, all supplies centered on typical values

Table 5: DWM3000 DC Characteristics

Parameter	Min.	Typ.	Max.	Units	Condition / Note
Supply current DEEP SLEEP mode		260		nA	Total current drawn from all supplies.
Supply current SLEEP mode		850		nA	
Supply current CH5 IDLE mode		12		mA	
Supply current CH9 IDLE mode		20		mA	
Supply current CH5 INIT mode		6		mA	
Supply current CH9 INIT mode		6		mA	
CH5 TX: 3.3 V supplies (VDD1, VDD3V3)		40		mA	
CH9 TX: 3.3 V supplies (VDD1, VDD3V3)		45		mA	
CH5 RX: 3.3 V supplies (VDD1, VDD3V3)		50		mA	Receiver active, no frames received
CH9 RX: 3.3 V supplies (VDD1, VDD3V3)		55		mA	Receiver active, no frames received
Digital input voltage high	0.7*VDD1			V	
Digital input voltage low			0.3*VDD1	V	
Digital output voltage high	0.7*VDD1			V	Assumes 500 Ω load
Digital output voltage low			0.3*VDD1	V	Assumes 500 Ω load
Digital Output Drive Current GPIOx, IRQ		0.8		mA	
Digital Output Drive Current SPIMISO	8	10		mA	
Digital Output Drive Current EXTON	3	4		mA	



4.3 Receiver AC Characteristics

T_{amb} = 25 °C, all supplies centered on nominal values

Table 6: DWM3000 Receiver AC Characteristics

Parameter	Min.	Typ.	Max.	Units	Condition / Note
Centre Frequency CH5		6489.6		MHz	
Centre Frequency CH9		7987.2			
Channel bandwidth		500			Channel 5 and 9

4.4 Reference Clock AC Characteristics

T_{amb} = 25 °C, all supplies centered on typical values

4.4.1 Reference Frequency

Table 7: Reference Clock AC Characteristics

Parameter	Min.	Typ.	Max.	Units	Condition / Note
On-board crystal oscillator reference frequency		38.4		MHz	
On-board crystal aging		±1		ppm in 1 st year	

4.5 Transmitter AC Characteristics

T_{amb} = 25 °C, all supplies centered on typical values

Table 8: DWM3000 Transmitter AC Characteristics

Parameter	Min.	Typ.	Max.	Units	Condition / Note
Frequency range	6250		8250	MHz	
Channel Bandwidths		500		MHz	Channel 5 and 9

4.6 Absolute Maximum Ratings

Table 9: DWM3000 Absolute Maximum Ratings

Parameter	Min.	Max.	Units
Voltage VDD3V3 / VDD1	-0.3	4.0	V
Receiver Power		0	dBm
Temperature - Storage temperature	-40	+125	°C
Temperature - Operating temperature	-40	+85	°C
ESD (Charged Device Model)		1000	V

Stresses beyond those listed in this table may cause permanent damage to the device. This is a stress rating only; functional operation of the device at these or any other conditions beyond those indicated in the operating conditions of the specification is not implied. Exposure to the absolute maximum rating conditions for extended periods may affect device reliability.

5 Antenna Performance

This section presents antenna radiation patterns for the DWM3000. As is illustrated in Figure 9, measured radiation patterns were made with the module mounted on a DWM3000EVB evaluation board.

Table 10 and Table 11 show antenna radiation patterns in channels 5 and 9, respectively. Three planes in spherical space about the centre of the board are measured, with theta and phi plots representing perpendicular polarisations.

The DWM3000 antenna is vertically polarised, meaning that the module is intended to be positioned vertically upright when used in an RTLS system. An omnidirectional radiation pattern is seen in the XZ plane when observed by another antenna which is also vertically polarised. This is shown in the XZ plane antenna patterns, where the vertically polarised plot, phi, has a circular, or omnidirectional shape.

If the antennas are oriented perpendicular relative to each other, then the polarisation changes. In this case, the horizontally polarised pattern, theta, applies and there are nulls at certain angles which can limit range and introduce location inaccuracy.

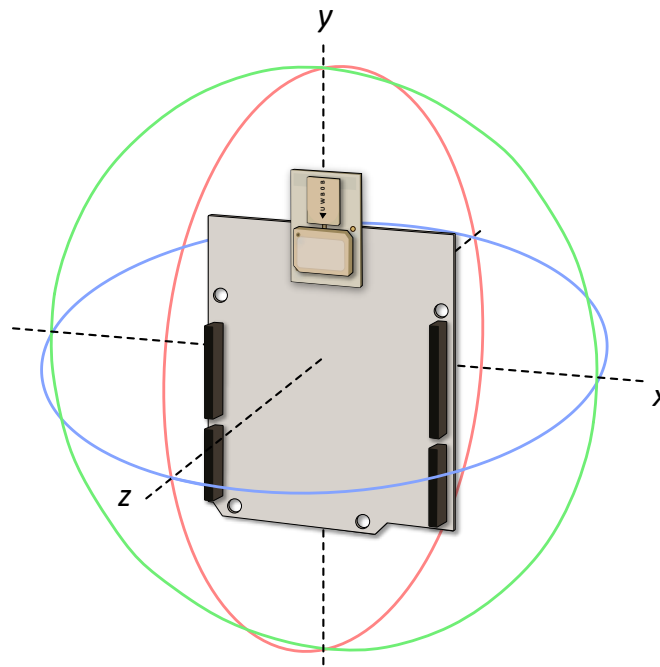

Figure 9: Radiation Pattern Planes

Table 10: Antenna Radiation Patterns - Channel 5

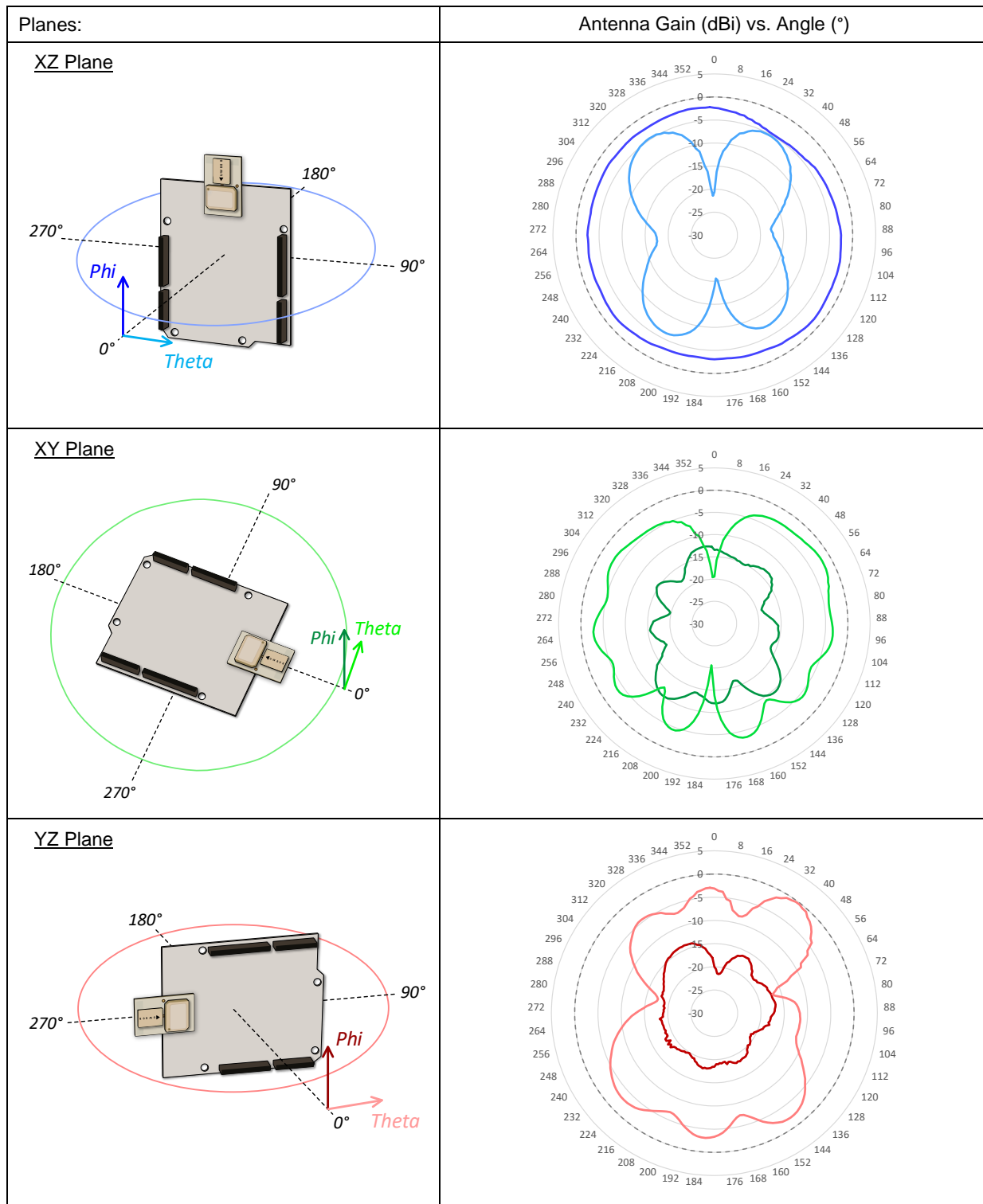
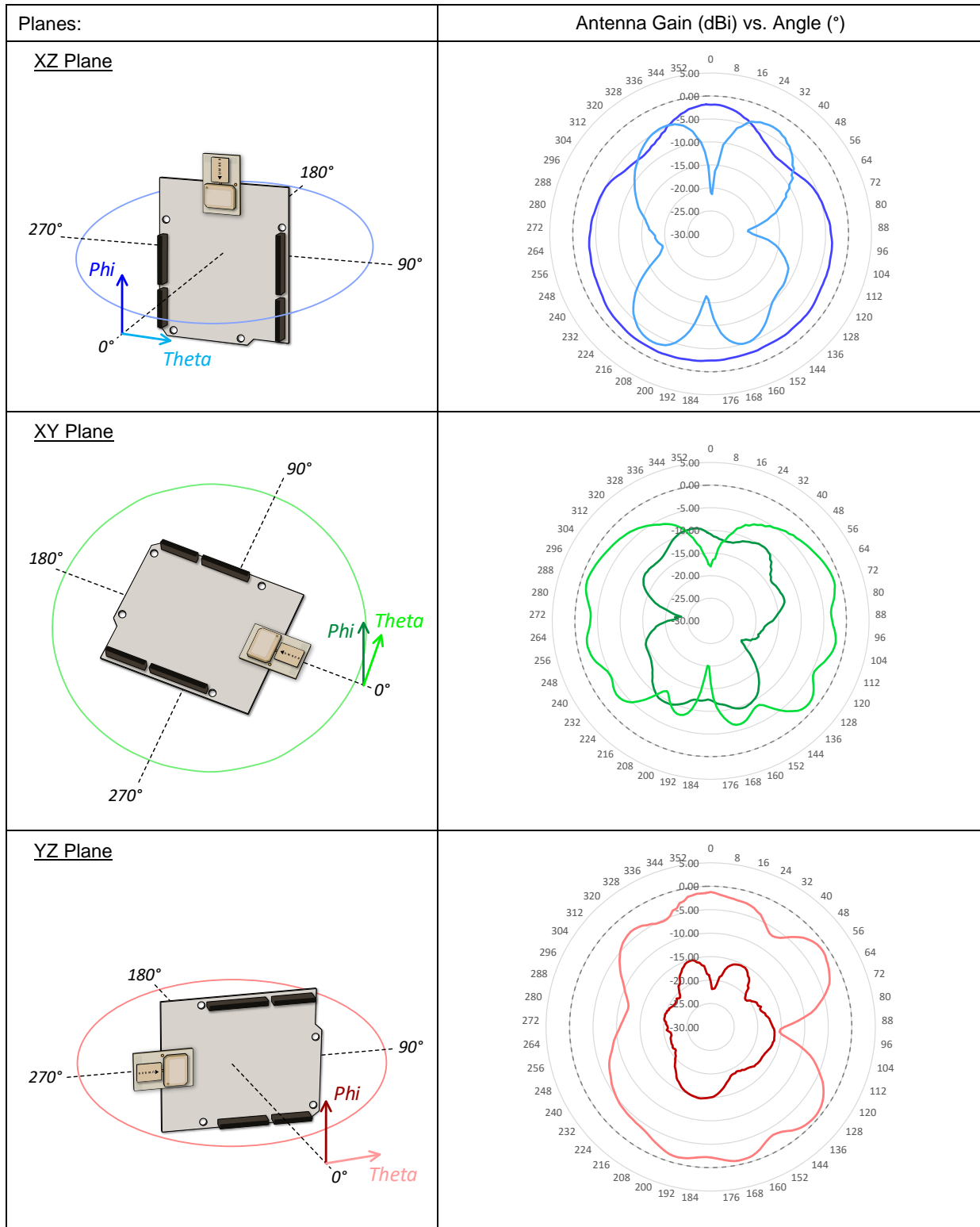

Table 11: Antenna Radiation Patterns - Channel 9



6 Application Information

6.1 Application Board Layout Guidelines

When designing the PCB onto which DWM3000 will be soldered, the proximity of the DWM3000 on-board ceramic monopole antenna to metal and other non-RF transparent materials needs to be considered carefully. Two suggested placement schemes are shown below.

For best RF performance, ground copper should be flooded in all areas of the application board, except in the areas marked “Keep-Out Area”, where there should be no metal either side, above or below (e.g., do not place battery under antenna).

The placement schemes in Figure 10 show an application board with no non-RF transparent material in the keep-out area, or an application board with the antenna projecting off of the board so that the keep out area is in free-space. In this second scheme it is still important not to place metal components above or below the antenna in a system implementation. It is also important to note that the ground plane on the application board affects the DWM3000 antenna radiation pattern. In Figure 10 below, ‘d’ should ideally be 10 mm. This gives the most vertically polarized radiation pattern. As ‘d’ is increased from 10 mm the degree of vertical polarization reduces.

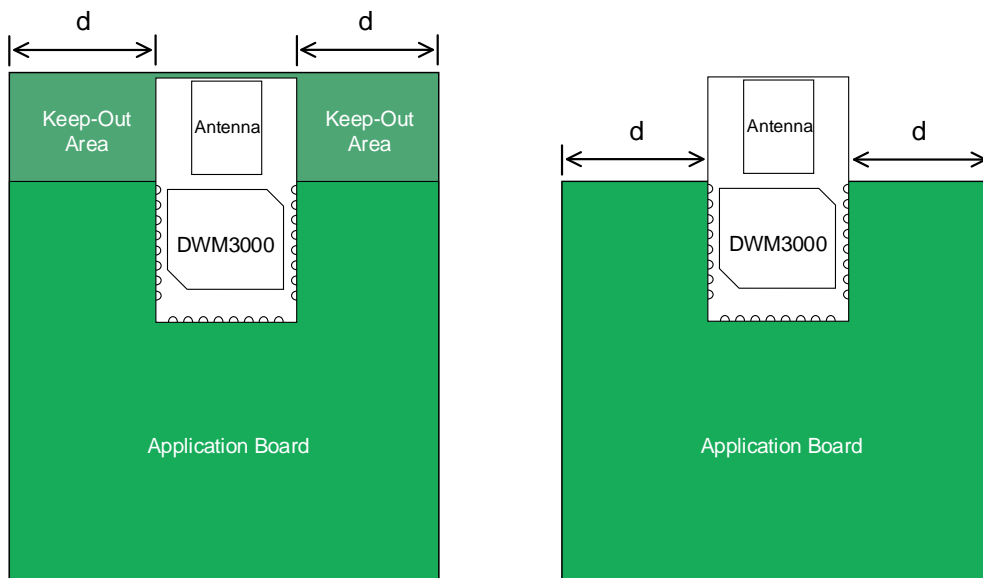

Figure 10: Application Board Keep-Out Areas

6.2 Application Circuit Diagram

A simple application circuit integrating the DWM3000 module need only power the device and connect the device to a host controller, see Figure 11.

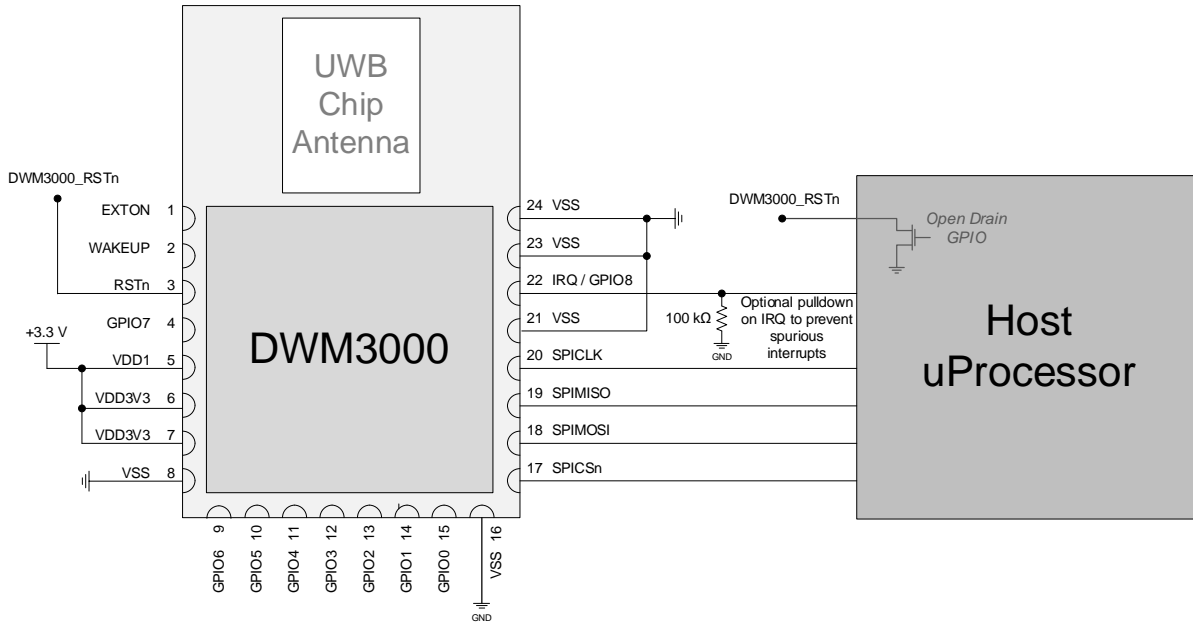

Figure 11: Example DWM3000 Application Circuit

6.3 GPIO and SPI I/O Internal Pull Up / Down

All of the GPIO pins have a software controllable internal pull up/down resistor to ensure safe operation when input pins are not driven. This defaults to enabled and pull-down except for the SPICSn pin which defaults to pull-up. The value of the pull-up / down will vary with the VDD1 supply voltage over a range from 10 kΩ to 30 kΩ.

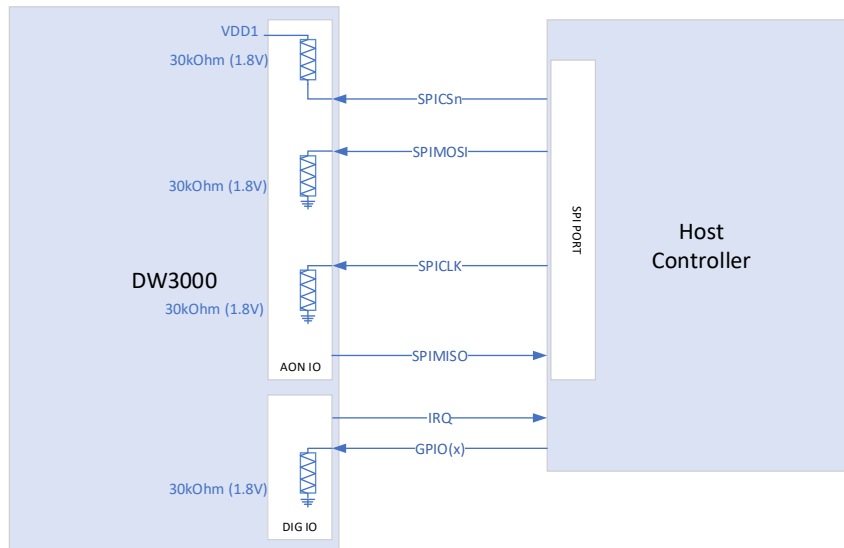

Figure 12: SPI and GPIO Pull Up / Down

7 Package Information

7.1 Module Drawings

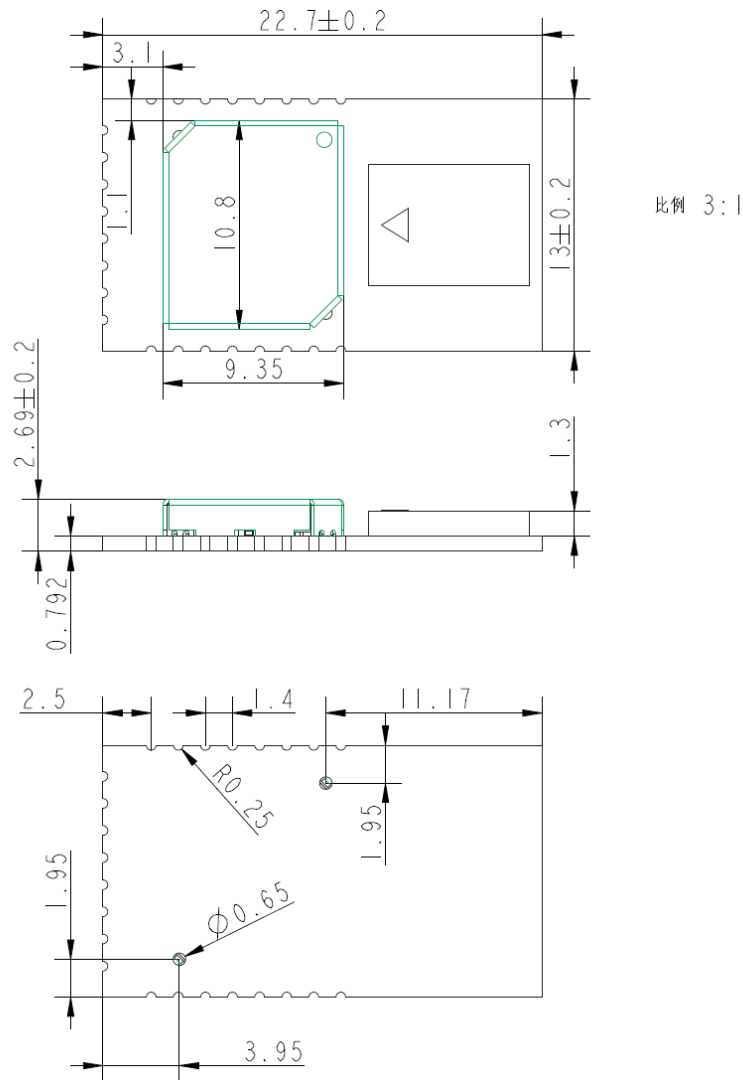

Figure 13: Module Package Size (mm)

7.2 Module Land Pattern

The diagram below shows the DWM3000 module land pattern.

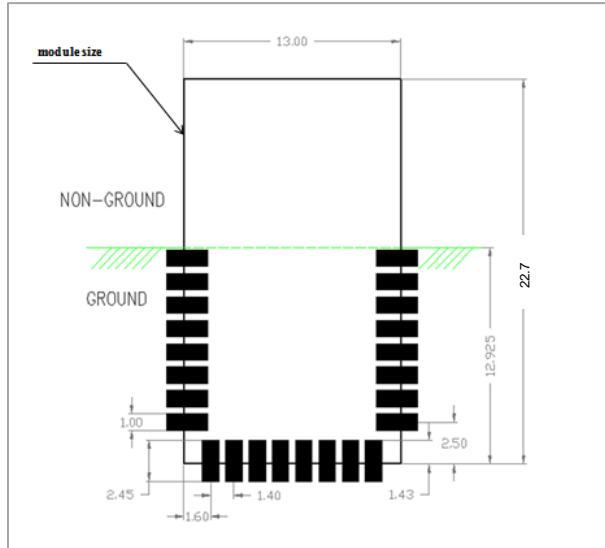

Figure 14: Module Land Pattern (units: mm)

7.3 Module Marking Information

The module is identified by a sticker on the shield can which gives the part number and serial number as follows: “YY” is year, “WW” is calendar week number (week code per ISO-8601), “3” is DWM3000, SSSSS is serial number: 00001, 00002.....

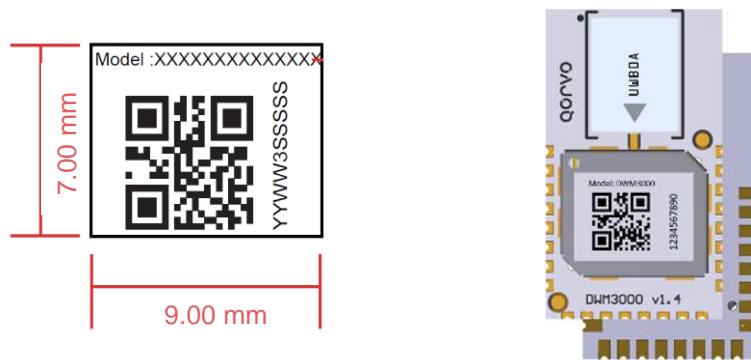
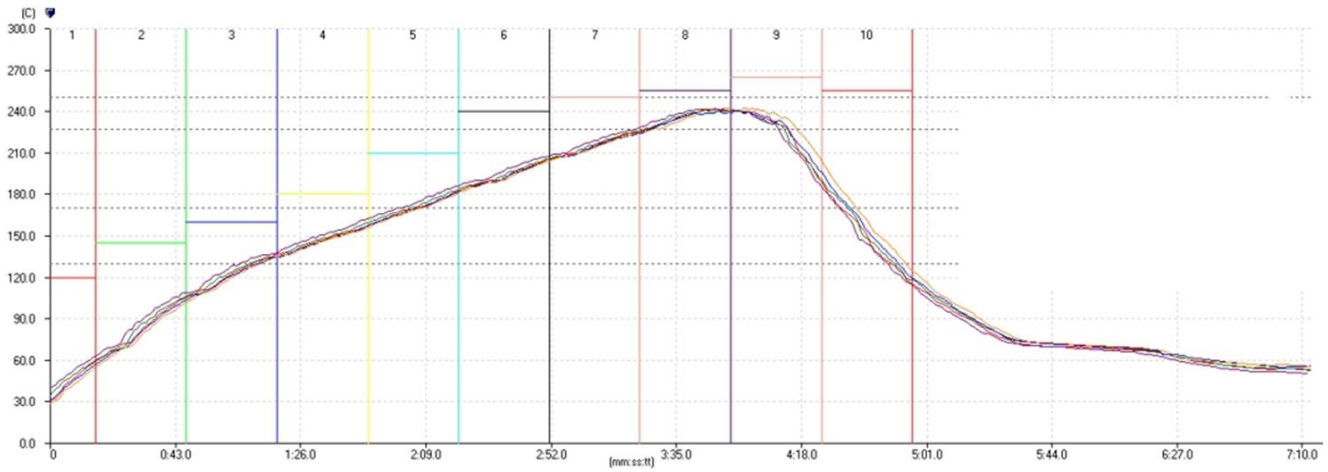

Figure 15: Module Marking Information

7.4 Module Solder Profile



	Range	Condition
Ascending slope	50 - 120 [°C]	1.0 - 2.0 [°C/s]
Preheat Time 1	130 - 170 [°C]	30 - 60 [s]
Preheat Time 2	170 - 227 [°C]	50 - 110 [s]
Reflow	> 227 [°C]	45 - 90 [s]
Decending slope	250 - 90 [°C]	1.0 - 4.0 [°C/s]
Temp Max.	250 [°C]	-

Figure 16: DWM3000 Module Solder Profile

7.5 Tape and Reel Information

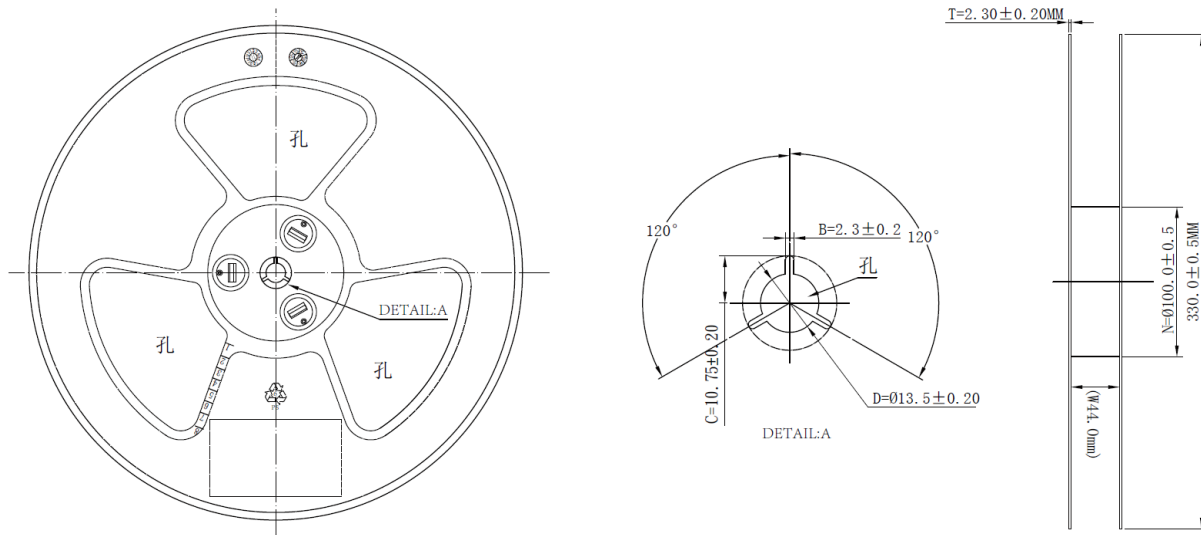

Figure 17: Module Carrier Dimension (mm)

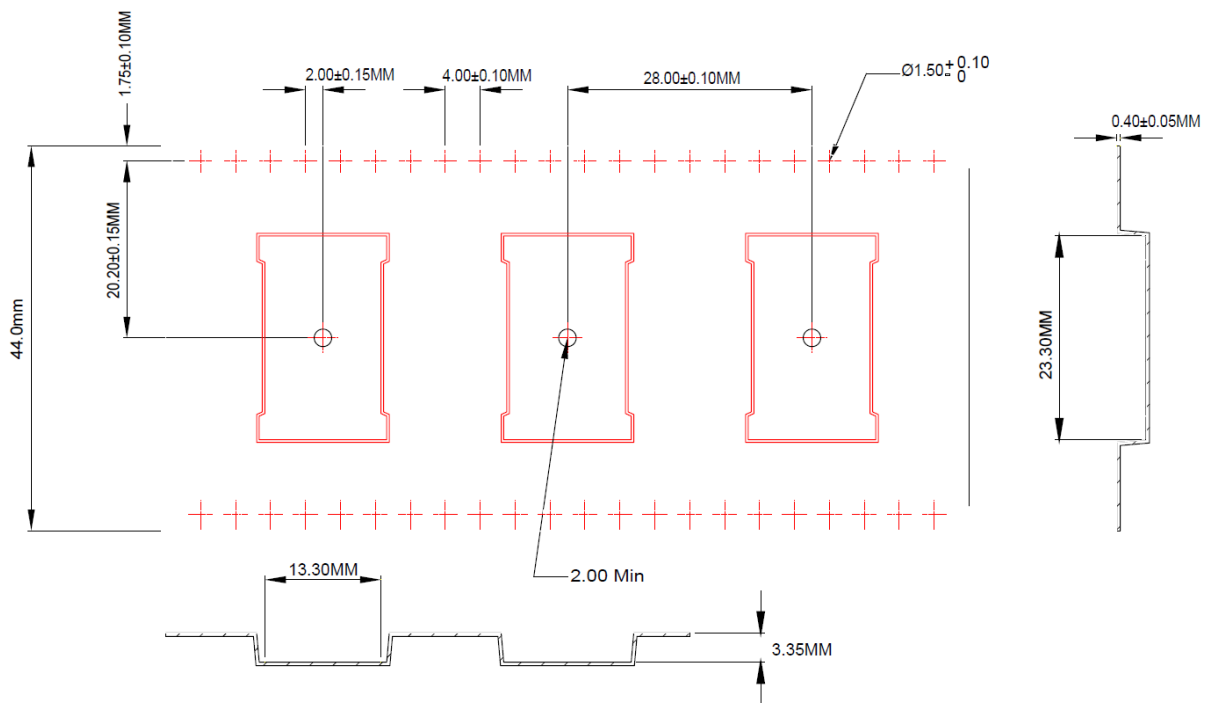

Figure 18: Module Tape Carrier Dimension (mm)

8 Glossary
Table 12: Glossary of Terms

Abbreviation	Full Title	Explanation
EIRP	Equivalent Isotropic Radiated Power	The amount of power that a theoretical isotropic antenna (which evenly distributes power in all directions) would emit to produce the peak power density observed in the direction of maximum gain of the antenna being used.
ETSI	European Telecommunication Standards Institute	Regulatory body in the EU charged with the management of the radio spectrum and the setting of regulations for devices that use it.
FCC	Federal Communications Commission	Regulatory body in the USA charged with the management of the radio spectrum and the setting of regulations for devices that use it.
GPIO	General Purpose Input / Output	Pin of an IC that can be configured as an input or output under software control and has no specifically identified function.
IEEE	Institute of Electrical and Electronic Engineers	Is the world's largest technical professional society. It is designed to serve professionals involved in all aspects of the electrical, electronic and computing fields and related areas of science and technology.
PLL	Phase Locked Loop	Circuit designed to generate a signal at a particular frequency whose phase is related to an incoming "reference" signal.
PPM	Parts Per Million	Used to quantify very small relative proportions. Just as 1% is one out of a hundred, 1 ppm is one part in a million.
RF	Radio Frequency	Generally used to refer to signals in the range of 3 kHz to 300 GHz. In the context of a radio receiver, the term is generally used to refer to circuits in a receiver before down-conversion takes place and in a transmitter after up-conversion takes place.
RTLS	Real Time Location System	System intended to provide information on the location of various items in real-time.
SFD	Start of Frame Delimiter	Defined in the context of the IEEE 802.15.4-2011 standard.
SPI	Serial Peripheral Interface	An industry standard method for interfacing between IC's using a synchronous serial scheme first introduced by Motorola.
TCXO	Temperature Controlled Crystal Oscillator	A crystal oscillator whose output frequency is very accurately maintained at its specified value over its specified temperature range of operation.
TWR	Two Way Ranging	Method of measuring the physical distance between two radio units by exchanging messages between the units and noting the times of transmission and reception. Refer to Qorvo's website for further information.
TDoA	Time Difference of Arrival	Method of deriving information on the location of a transmitter. The time of arrival of a transmission at two physically different locations whose clocks are synchronized is noted and the difference in the arrival times provides information on the location of the transmitter. A number of such TDoA measurements at different locations can be used to uniquely determine the position of the transmitter. Refer to Qorvo's website for further information.
UWB	Ultra-Wideband	A radio scheme employing channel bandwidths of, or in excess of, 500 MHz.
WSN	Wireless Sensor Network	A network of wireless nodes intended to enable the monitoring and control of the physical environment.

9 Revision History

Revision		Change Description
A		Preliminary version
B	May 2021	Updated for production release, completion of outstanding information.

10 Further Information

Qorvo develops semiconductors solutions, software, modules, reference designs - that enable real-time, ultra-accurate, ultra-reliable local area micro-location services. Qorvo's technology enables an entirely new class of easy to implement, highly secure, intelligent location functionality and services for IoT and smart consumer products and applications.

For further information on this or any other Qorvo product, please refer to our website www.qorvo.com.

Handling Precautions

Parameter	Rating	Standard
ESD - Charged Device Model (CDM)	1000V	ANSI/ESDA/JEDEC JS-002
MSL – Moisture Sensitivity Level	Level 3	IPC/JEDEC J-STD-020



Caution!
ESD-Sensitive Device

Regulatory Approvals

The DWM3000, as supplied from Qorvo, has not been certified for use in any particular geographic region by the appropriate regulatory body governing radio emissions in that region although it is capable of such certification depending on the region and the manner in which it is used.

All products developed by the user incorporating the DWM3000 must be approved by the relevant authority governing radio emissions in any given jurisdiction prior to the marketing or sale of such products in that jurisdiction and user bears all responsibility for obtaining such approval as needed from the appropriate authorities.

RoHS Compliance

This part is compliant with 2011/65/EU RoHS directive (Restrictions on the Use of Certain Hazardous Substances in Electrical and Electronic Equipment) as amended by Directive 2015/863/EU.

This product also has the following attributes:

- Antimony Free
- TBBP-A (C₁₅H₁₂Br₄O₂) Free
- SVHC Free