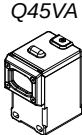
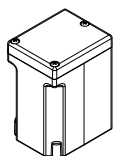

## Q45VA and VAC Features

The Wireless Q45VA/VAC All-in-One Sensor Node combines Banner's VT1 Vibration and Temperature Sensor with the Sure Cross® Q45VT Wireless Sensor Node. The Q45VA/VAC is a compact, industrial, battery-powered device that wirelessly communicates with any Sure Cross Performance Gateway on a variety of machines to analyze vibration and temperature data to identify and predict failures in rotating machinery.

### Benefits

- Delivers pre-processed high accuracy vibration values for monitoring rotating equipment such as:
  - Motors
  - Pumps
  - Rotary Compressors
  - Exhaust or HVAC fan motors
  - Spindles
- Easy-to-use rugged device that can be easily mounted to equipment
- Use with the DXM Wireless Controller to track and trend vibration and temperature characteristics in real time to predict need for maintenance, predict potential component failure and avoid process downtime.
- Battery powered for “peel and stick” functionality with 2+ years of battery life
- Detects vibration characteristics on 2 axis (radial and axial) such as RMS Velocity, High Frequency Acceleration, Peak Acceleration, Peak Velocity Component Frequency, etc.
- Achieves vibration accuracy of  $\pm 10\%$  RMS velocity (in/sec)
- **Eliminate control wires**—The Sure Cross wireless system is a radio frequency network with integrated I/O that removes the need for power and control wires
- **Reduce complexity**—Machine or process reconfiguration made easier; great for retrofit applications
- **Deploy easily**—Simplifying installation on existing equipment enables deployment in remote and hard-to-access locations where implementing a wired solution would be difficult, impractical, or not cost-effective

 <p>Q45VA</p>	<ul style="list-style-type: none"> <li>• Transmit power levels of 250 mW or 1 Watt for 900 MHz models and 65 mW for 2.4 GHz models are user-selectable</li> <li>• DIP switches for user configuration of sample time and vibration characteristics</li> <li>• Frequency Hopping Spread Spectrum (FHSS) technology ensures reliable data delivery</li> <li>• Transceivers provide bidirectional communication between the Gateway and Node, including fully acknowledged data transmission</li> <li>• Diagnostics allow user-defined output settings in the unlikely event of a lost radio signal</li> </ul>	 <p>Q45VAC</p>
---	---	--

## Q45VA and VAC Models

Models	Frequency	Description
DX80N2Q45VA	2.4 GHz	Two lithium AA batteries
DX80N9Q45VA	900 MHz	Two lithium AA batteries
DX80N9Q45VA-BK		Includes two lithium AA batteries and <b>BWA-Q45VA-FESS</b> and <b>BWA-Q45VA-CMSS</b> mounting brackets
DX80N2Q45VAC	2.4 GHz	One c-cell battery
DX80N9Q45VAC	900 MHz	One c-cell battery

To order the models without batteries, add an **NB** to the model number. For example, **DX80N2Q45VA NB**.

## Storage Mode

While in **storage mode**, the device's radio does not operate to conserve the battery. To put any device into storage mode, press and hold the binding button for five seconds. The device is in storage mode when the LEDs stop blinking. To wake the device, press and hold the binding button (inside the housing on the radio board) for five seconds.

## General Operation

For the first 15 minutes after power up, the Node samples the sensor every two seconds (fast sample mode). After 15 minutes, the Node defaults to five-minute sample intervals. Activate fast sample mode by single clicking the button (the amber LED is solid).

ISO 10816 provides guidance for evaluating vibration velocity severity motors, pumps, fans, compressors, gear boxes, blowers, dryers, presses, and other machines that operate in the 10 to 1000 Hz frequency range.

Vibration Severity per ISO 10816

Machine		Class I	Class II	Class III	Class IV	
Vibration Velocity Vrms	in/s	Small Machines	Medium Machines	Large Rigid Foundation	Large Soft Foundation	
	mm/s					
	0.01	0.28				
	0.02	0.45				
	0.03	0.71		good		
	0.04	1.12				
	0.07	1.80				
	0.11	2.80		satisfactory		
	0.18	4.50				
	0.28	7.10		unsatisfactory		
	0.44	11.2				
	0.70	18.0				
	1.10	28.0		unacceptable		
1.77	45.9					

## Button and LEDs for the Q45VA/VAC



1. Button
2. Red LED (flashing) indicates a radio link error with the Gateway.
3. Green LED (flashing) indicates a good radio link with the Gateway.
4. Amber LED is not used.
5. DIP Switches

## Installing the Q45VA

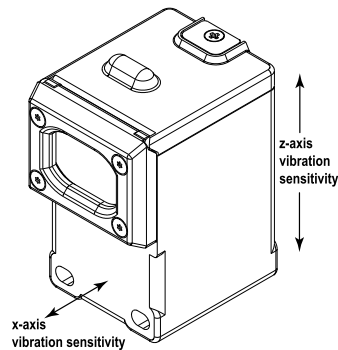

The vibration sensors have an x- and z-axis indication on the face of the sensor.

- Install the x-axis in line with the shaft of the motor or axially.
- Install the z-axis to go into or through the motor or radial.

For the best results, install the sensor as close to the motor bearing as possible. If this is not possible, install the sensor on a surface that is in rigid connection with vibration characteristics of the motor. Using a cover shroud or other flexible mounting location may result in reduced accuracy or reduced ability to detect certain vibration characteristics.

The Q45VA body can be affixed to the motor using Loctite 330 and 7387 Activator or similar two-part epoxy. For information about optional brackets, see "[Brackets/Installation for the Q45VA](#)" on [page 10](#).

## Configuration Instructions

### Bind to the Gateway and Assign the Node Address

Before beginning the binding procedure, apply power to all the devices. Separate the devices by two meters when running the binding procedure. Put only one Gateway into binding at a time to prevent binding to the wrong Gateway.

1. On the Gateway: Enter binding mode.
  - For housed DX80 Gateways, triple-click button 2 on the Gateway. Both LEDs flash red.
  - For Gateway board modules, triple-click the button. The green and red LED flashes.
2. Assign the Q45VA/VAC a Node address using the Gateway's rotary dials. Use the left rotary dial for the left digit and the right rotary dial for the right digit. For example, to assign your Q45VA/VAC to Node 10, set the Gateway's left dial to 1 and the right dial to 0. Valid Node addresses are 01 through 47.
3. On the Q45: Loosen the clamp plate on the top of the Q45VA/VAC and lift the cover.
4. Enter binding mode on the Q45VA/VAC by triple-clicking the Q45VA/VAC's button. The red and green LEDs flash alternately and the sensor searches for a Gateway in binding mode. After the Q45VA/VAC is bound, the LEDs stay solid momentarily, then they flash together four times. The Q45VA/VAC exits binding mode.
5. Label the sensor with the Q45VA/VAC's Node address number for future reference.
6. Repeat steps 2 through 5 for as many Q45VA/VACs as are needed for your network.
7. On the Gateway: After binding all Q45VA/VACs, exit binding mode.
  - For housed DX80 Gateways, double-click button 2.
  - For board-level DX80 Gateways, double-click the button.

For Gateways with single-line LCDs: After binding your Q45VA/VAC to the Gateway, make note of the binding code displayed under the Gateway's \*DVCFG menu, XADR submenu on the LCD. Knowing the binding code prevents having to re-bind all Q45VA/VACs if your Gateway is ever replaced.

### Bind to a DXM and Assign the Node Address

Before beginning the binding procedure, apply power to all the devices. Separate the radios by two meters when running the binding procedure. Put only one DXM into binding mode at a time to prevent the Q45VA/VAC from binding to the wrong Gateway.

1. On the DXM: Use the arrow keys to select the **ISM Radio** menu on the LCD and click **ENTER**.
2. Highlight the **Binding** menu and click **ENTER**.
3. Use the arrow keys to select the Node address to bind the Q45VA/VAC to.
4. On the Q45VA/VAC: Loosen the top clamp plate and lift the cover.
5. Enter binding mode by triple-clicking the binding button. The red and green LEDs flash alternately and the sensor searches for a Gateway in binding mode. After the Node binds, the LEDs stay solid momentarily, then they flash together four times. The Node exits binding mode.
6. Label the sensor with the Node address number for future reference.
7. On the DXM: Click **BACK** to exit binding for that specific Node address.
8. Repeat steps 3 through 7 and change the Node address for as many Q45VA/VACs as are needed for your network.
9. On the DXM: After you have finished forming your network, click **BACK** until you reach the main menu.

### Q45VA and VAC DIP Switches

After making any changes to any DIP switch position, reboot the Q45VA/VAC by triple-clicking the button, waiting a second, then double-clicking the button.

The DIP switches are in the OFF position. To turn a DIP switch on, push the switch toward the battery pack. DIP switches one through four are numbered from left to right.

#### DIP switch settings

Description	DIP Switches							
	1	2	3	4	5	6	7	8
Transmit power: 1 Watt (default setting)	OFF*							
Transmit power: 250 mW (compatible with 150 mW radios)	ON							
Default I/O Configuration (default setting) <sup>(1)</sup>		OFF*	OFF*	OFF*				
I/O Configuration 1		OFF	OFF	ON				

Continued on page 4

<sup>(1)</sup> User configurable if switch 7 is OFF; for input serial addresses, see "[Modbus Registers and I/O Serial Addresses](#)" on page 5

Continued from page 3

Description	DIP Switches							
	1	2	3	4	5	6	7	8
I/O Configuration 2		OFF	ON	OFF				
I/O Configuration 3		OFF	ON	ON				
I/O Configuration 4		ON	OFF	OFF				
I/O Configuration 5		ON	OFF	ON				
Reserved		ON	ON	OFF				
Reserved		ON	ON	ON				
Sample/Report Rate: User configured (5 minutes by default) (default setting)					OFF*	OFF*		
Sample/Report Rate: 150 seconds					OFF	ON		
Sample/Report Rate: 60 seconds					ON	OFF		
Reserved					ON	ON		
English Units (in/s and °F) (default setting)							OFF*	
Metric Units (mm/s and °C)							ON	
Reserved (default setting)								OFF*

*I/O Configurations (Set by DIP Switches 2, 3, and 4)*

Input Register		Default I/O	I/O Configuration 1	I/O Configuration 2	I/O Configuration 3	I/O Configuration 4	I/O Configuration 5
1	Z-Axis	RMS Velocity (in/sec)	RMS Velocity (in/sec)	High-Frequency RMS Acceleration (G)	RMS Velocity (in/sec)	Full Bandwidth RMS Acceleration (G)	RMS Velocity (in/sec)
2		High-Frequency RMS Acceleration (G)	Peak Acceleration (G)	Peak Acceleration (G)	Peak Velocity Component Frequency (Hz)	Full Bandwidth Peak Acceleration (G)	Full Bandwidth RMS Acceleration (G)
3	-	Temperature (°F)	Temperature (°F)	Temperature (°F)	Temperature (°F)	Temperature (°F)	Temperature (°F)
4	-	Reserved	Reserved	Reserved	Reserved	Reserved	Reserved
5	X-Axis	RMS Velocity (in/sec)	RMS Velocity (in/sec)	High-Frequency RMS Acceleration (G)	RMS Velocity (in/sec)	Full Bandwidth RMS Acceleration (G)	RMS Velocity (in/sec)
6		High-Frequency RMS Acceleration (G)	Peak Acceleration (G)	Peak Acceleration (G)	Peak Velocity Component Frequency (Hz)	Full Bandwidth Peak Acceleration (G)	Full Bandwidth RMS Acceleration (G)

If DIP switch 7 is on, all in/s units change to mm/s. DIP switch 7 will only switch units with DIP switch I/O configurations, not with any user configuration.

## Configure the Q45 Using the Configuration Software

The DXM Performance Configuration Software offers an easy way to change sensor settings, show sensor data from different sensors, and retrieve data from the Gateway radio. The software runs on any Windows computer and uses an adapter cable to connect the Gateway to your computer.

Download the most recent version of the software from Banner Engineering's website: [www.bannerengineering.com/wireless](http://www.bannerengineering.com/wireless).

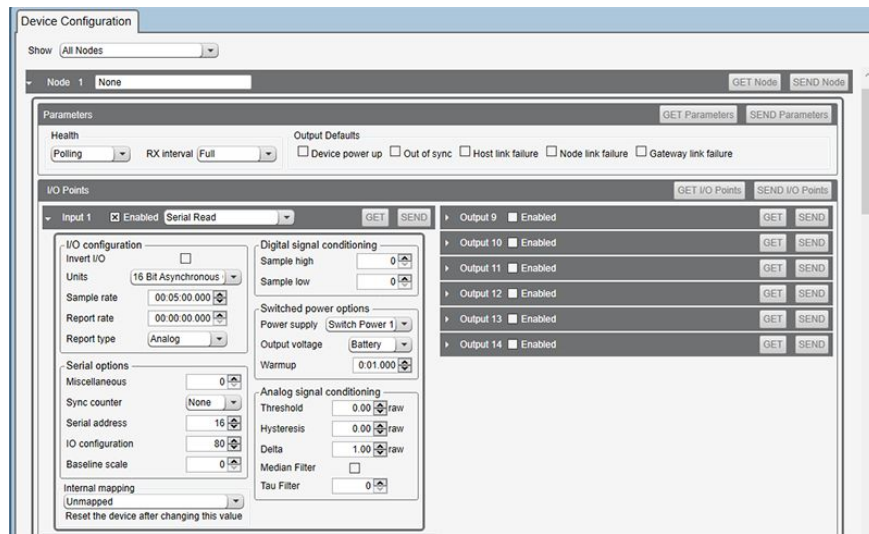

1. Go to the **Configuration > Device Configuration** screen.
2. On the top of the screen, select **Nodes Currently in the System** from the drop-down list and click **Get devices in system**.  
All Nodes bound to the Gateway connected to the computer display.
3. Click the arrow next to the Nodes to display the parameters specific to that Node.  
In this example, the parameters for Node 1 are shown.
4. Under the Node 1 I/O points section, click **GET I/O Points**.  
All I/O types for this Node are loaded onto the screen.
5. To view the parameters for an I/O point, click the arrow next to that I/O point.  
In this example, the parameters for I/O point 1 are shown.
6. To set the **Serial address**, go to the **Serial options** section of the I/O point's parameters and enter the value.  
In this example, the **Serial address** is set to 16 for output Z-Axis RMS Velocity (in/sec).
7. After making changes to the I/O point parameters, click **SEND** to send the changes to the network.
8. Repeat steps 5 and 8 for each input to manually change the configuration of the vibration parameters by changing the serial address.

For more information on using the DX80 Performance Configuration Software, refer to the instruction manual (p/n [140628](#)).

## Modbus Registers and I/O Serial Addresses

### I/O serial addresses

Serial Address	Output Type	I/O Range		Holding Register Representation	
		Min	Max	Min (Dec)	Max (Dec)
16	Z-Axis RMS Velocity (in/sec) <sup>1, 5</sup>	0	6.5535	0	65535
25	Z-Axis High-Frequency RMS Acceleration <sup>2, 6</sup>	0	65.535	0	65535
-	Reserved	-	-	-	-
64	X-Axis RMS Velocity (in/sec) <sup>1, 5</sup>	0	6.5535	0	65535
73	X-Axis High-Frequency RMS Acceleration (G) <sup>2, 6</sup>	0	65.535	0	65535
20	Z-Axis Peak Acceleration (G) <sup>2, 6</sup>	0	65.535	0	65535
68	X-Axis Peak Acceleration (G) <sup>2, 6</sup>	0	65.535	0	65535
18	Z-Axis Peak Velocity Component Frequency (Hz) <sup>4, 5</sup>	0	6553.5	0	65535
66	X-Axis Peak Velocity Component Frequency (Hz) <sup>4, 5</sup>	0	6553.5	0	65535
19	Z-Axis RMS Acceleration (G) <sup>2, 5</sup>	0	65.535	0	65535
67	X-Axis RMS Acceleration (G) <sup>2, 5</sup>	0	65.535	0	65535
24	Z-Axis Kurtosis <sup>2, 6</sup>	0	65.535	0	65535
72	X-Axis Kurtosis <sup>2, 6</sup>	0	65.535	0	65535
37	Z-Axis Crest Factor <sup>2, 6</sup>	0	65.535	0	65535

Continued on page 6

Continued from page 5

Serial Address	Output Type	I/O Range		Holding Register Representation	
		Min	Max	Min (Dec)	Max (Dec)
69	X-Axis Crest Factor <sup>2, 6</sup>	0	65.535	0	65535
17	Z-Axis Peak Velocity (in/sec) <sup>1, 5</sup>	0	6.5535	0	65535
23	Z-Axis Peak Velocity (mm/sec) <sup>2, 5</sup>	0	65.535	0	65535
65	X-Axis Peak Velocity (in/sec) <sup>1, 5</sup>	0	6.5535	0	65535
71	X-Axis Peak Velocity (mm/sec) <sup>2, 5</sup>	0	65.535	0	65535
22	Z-Axis RMS Velocity (mm/sec) <sup>2, 5</sup>	0	65.535	0	65535
70	X-Axis RMS Velocity (mm/sec) <sup>2, 5</sup>	0	65.535	0	65535
27	Full Bandwidth RMS Acceleration Z-Axis (G) <sup>2, 7</sup>	0	65.535	0	65535
75	Full Bandwidth RMS Acceleration X-Axis (G) <sup>2, 7</sup>	0	65.535	0	65535
28	Full Bandwidth Peak Acceleration Z-Axis (G) <sup>2, 7</sup>	0	65.535	0	65535
76	Full Bandwidth Peak Acceleration X-Axis (G) <sup>2, 7</sup>	0	65.535	0	65535
192	Temperature (°C) <sup>3</sup>	-1638.4	1638.4	-32768	32767
193	Temperature (°F) <sup>3</sup>	-1638.4	1638.4	-32768	32767

<sup>1</sup> Value = Register value ÷ 10000

<sup>2</sup> Value = Register value ÷ 1000

<sup>3</sup> Value = Register value ÷ 20

<sup>4</sup> Value = Register value ÷ 10

<sup>5</sup> Measurement bandwidth = 10 Hz to 1 kHz

<sup>6</sup> Measurement bandwidth = 1 kHz to 4 kHz

<sup>7</sup> Measurement Bandwidth = 10 Hz to 4 kHz

*Modbus holding registers*

I/O #	Modbus Holding Register		I/O Type	I/O Range		Holding Register Representation	
	Gateway	Any Node		Min.	Max.	Min.	Max.
1	1	1 + (Node# × 16)	Sensor Input Register 1				
2	2	2 + (Node# × 16)	Sensor Input Register 2				
3	3	3 + (Node# × 16)	Sensor Input Register 3				
4	4	4 + (Node# × 16)	Sensor Input Register 4				
5	5	5 + (Node# × 16)	Sensor Input Register 5				
6	6	6 + (Node# × 16)	Sensor Input Register 6				
7	7	7 + (Node# × 16)	Reserved				
8	8	8 + (Node# × 16)	Device Message				
		...					
15	15	15 + (Node# × 16)	Control Message				
16	16	16 + (Node# × 16)	Reserved				

By default, data is supplied to the Node every five minutes, unless the Node requests the data sooner. The default configuration is shown and all optional outputs types are listed. Use the User Configuration Software to adjust the Sensor Register output type. Temperature values outside the operating range of the device are forced to the maximum or minimum values.

## Apply Power to the Q45 AA-Cell Models

Follow these instructions to install or replace the lithium "AA" cell batteries.

**CAUTION:**

- **As with all batteries, these are fire, explosion, and severe burn hazards. There is a risk of explosion if the battery is replaced incorrectly.**
- Do not burn or expose them to high temperatures. Do not recharge, crush, disassemble, or expose the contents to water.
- Verify the battery's positive and negative terminals align to the positive and negative terminals of the battery holder mounted within the case.
- Properly dispose of used batteries according to local regulations by taking them to a hazardous waste collection site, an e-waste disposal center, or another facility qualified to accept lithium batteries.

Q45 battery board

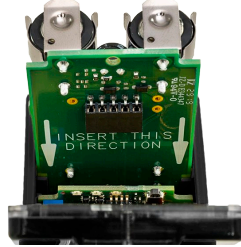

1. Loosen the clamp plate with a small Phillips screwdriver and lift the cover.
2. Slide the battery board out of the Q45 housing.
3. If applicable, remove the discharged batteries.
4. Install the new batteries.

Use Banner's **BWA-BATT-006** replacement batteries or equivalent 3.6 V AA lithium batteries, such as Xeno's XL-60F.

5. Verify the battery's positive and negative terminals align to the positive and negative terminals of the battery holder mounted within the case.
6. Slide the board containing the new batteries back into the Q45 housing.
7. Close the cover and gently tighten the clamp plate with the small Phillips screwdriver.

## Apply Power to the Q45 C-Cell Models

Follow these instructions to install or replace the lithium C cell batteries.

**CAUTION:**

- **As with all batteries, these are fire, explosion, and severe burn hazards. There is a risk of explosion if the battery is replaced incorrectly.**
- Do not burn or expose them to high temperatures. Do not recharge, crush, disassemble, or expose the contents to water.
- Verify the battery's positive and negative terminals align to the positive and negative terminals of the battery holder mounted within the case.
- Properly dispose of used batteries according to local regulations by taking them to a hazardous waste collection site, an e-waste disposal center, or another facility qualified to accept lithium batteries.

Q45 battery board for c-cell batteries



1. Lift the plastic cover.
2. Slide the board containing the batteries out of the Q45 housing.
3. Remove the discharged battery and replace with new battery.  
The replacement battery model number is **BWA-BATT-013**. For pricing and availability, contact Banner Engineering.
4. Verify the battery's positive and negative terminals align to the positive and negative terminals of the battery holder mounted within the case.
5. Slide the board containing the new batteries back into the Q45 housing.

## Specifications

---

### Radio Specifications for Performance with Internal Antenna

#### Supplied Antenna

This device includes an internal 2 dB antenna. Range depends on the environment and decreases significantly without line-of-sight. Always verify your wireless network's range by performing a Site Survey.

#### Radio Transmit Power (900 MHz, 1 Watt radios)

Conducted: 30 dBm (1 W)  
EIRP with the supplied 2 dB antenna: < 36 dBm

#### Radio Transmit Power (2.4 GHz radios)

Conducted: < 18 dBm (65 mW)  
EIRP with the supplied 2 dB antenna: < 20 dBm (100 mW)

#### Antenna Minimum Separation Distance

900 MHz (transmitting at 150 mW and 250 mW): 2 m (6 ft) with the supplied 2 dB antenna  
900 MHz (transmitting at 1 Watt): 4.57 m (15 ft) with the supplied 2 dB antenna  
2.4 GHz: 0.3 m (1 ft) with the supplied 2 dB antenna

#### Radio Range

900 MHz (in 1 Watt mode): Up to 3.2 km (2 miles) with line of sight (internal antenna)  
2.4 GHz: Up to 1000 m (3280 ft) with line of sight (internal antenna)

#### Spread Spectrum Technology

FHSS (Frequency Hopping Spread Spectrum)

#### Link Timeout (Performance)

Gateway: Configurable via User Configuration Software  
Node: Defined by Gateway

#### 900 MHz Compliance (SX7023 Radio Module)

Radio module is indicated by the product label marking  
Contains FCC ID: UE3SX7023EXT: FCC Part 15, Subpart C, 15.247  
Contains IC: 7044A-SX7023EXT

#### 900 MHz Compliance (RM1809 Radio Module)

Radio module is indicated by the product label marking  
Contains FCC ID: UE3RM1809: FCC Part 15, Subpart C, 15.247  
Contains IC: 7044A-RM1809  
IFT: RCPBARM13-2283



#### 2.4 GHz Compliance (DX80-2400 Radio Module)

Radio module is indicated by the product label marking  
Contains FCC ID: UE300DX80-2400: FCC Part 15, Subpart C, 15.247  
Radio Equipment Directive (RED) 2014/53/EU  
Contains IC: 7044A-DX8024  
ANATEL: 15966-21-04042



#### 2.4 GHz Compliance (SX243 Radio Module)

Radio module is indicated by the product label marking  
Contains FCC ID: UE3SX243: FCC Part 15, Subpart C, 15.247  
Radio Equipment Directive (RED) 2014/53/EU  
ETSI/EN: EN 300 328 V2.2.2 (2019-07) [RED HarmStds]  
Contains IC: 7044A-SX243  
ANATEL: 03737-22-04042



### Q45VA and VAC Specifications

#### Default Sensing Interval

5 minutes

#### Indicators

Red and green LEDs (radio function)

#### Construction

Molded reinforced thermoplastic polyester housing, oring-sealed transparent Lexan® cover, molded acrylic lenses, and stainless steel hardware. Designed to withstand 1200 psi washdown.

#### Shock

400G

#### Environmental Rating

NEMA 6P, IP67

#### Typical Battery Life

See chart.

#### Vibration Sensor

Measuring Range: 0 to 46 mm/sec or 0 to 1.8 in/sec RMS  
Frequency Range: 10 Hz to 4 kHz  
Accuracy: ±10% at 25 °C  
Sampling Frequency: 20 kHz (default)  
Record Length: 8192 points (default)  
Sample Duration: 0.4 s (default)

#### Temperature Sensor

Measuring Range: -40 °C to +105 °C (-40 °F to +221 °F)

#### Operating Conditions

Ambient temperature: -40 °C to +70 °C (-40 °F to +158 °F)  
Contact temperature: -40 °C to +105 °C (-40 °F to +221 °F)  
90% at +50 °C maximum relative humidity (non-condensing)  
Radiated Immunity HF: 10 V/m (EN 61000-4-3)



Certifications



Banner Engineering BV  
Park Lane, Culliganlaan 2F bus 3  
1831 Diegem, BELGIUM



Turck Banner LTD Blenheim House  
Blenheim Court  
Wickford, Essex SS11 8YT  
GREAT BRITAIN

(CE/UKCA approval only applies to 2.4 GHz models)

Dimensions

All measurements are listed in millimeters, unless noted otherwise.

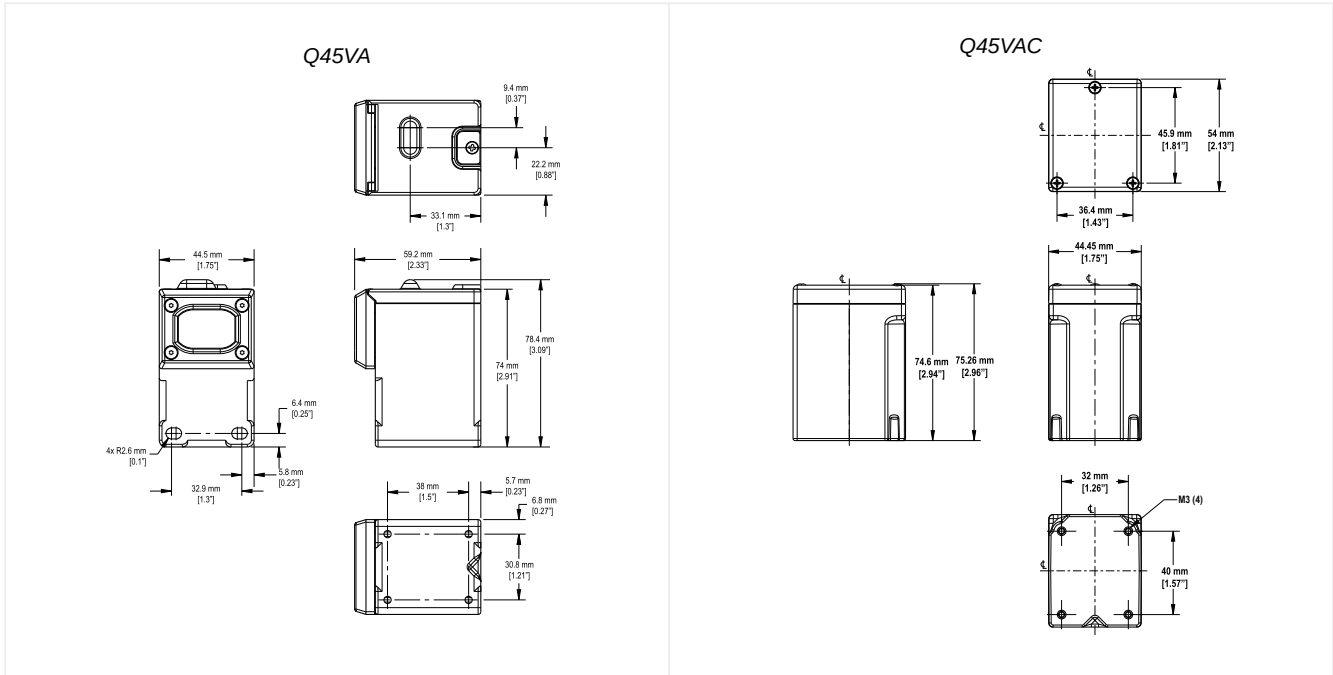

Battery Life for the Q45VA/VAC

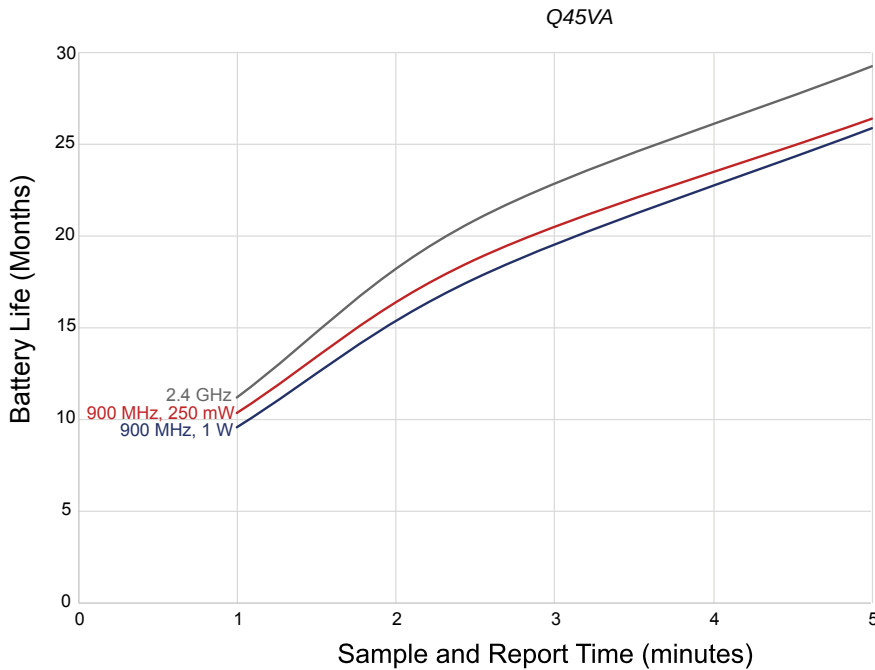

Q45VAC

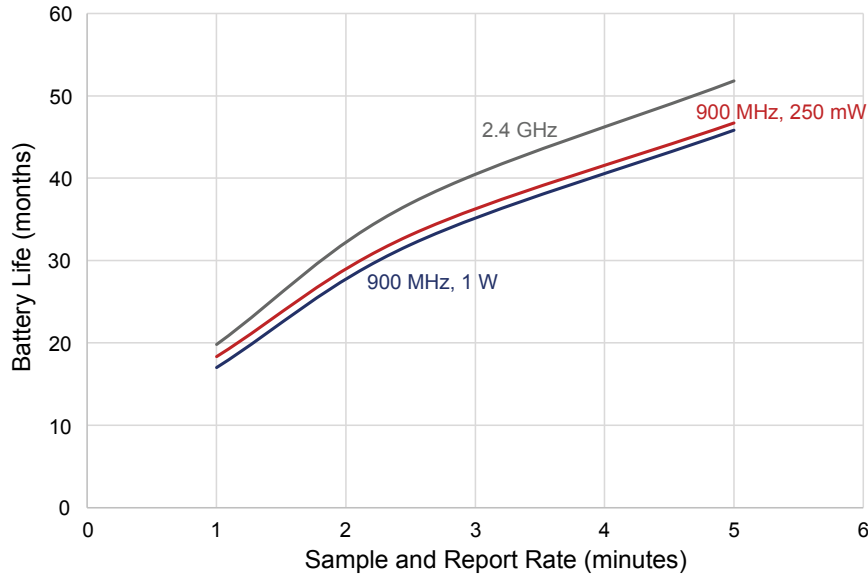

## Accessories

### Brackets/Installation for the Q45VA

**BWA-Q45VA-FESS**

- Mounts the device to a surface using two-part epoxy
- Alignment mark indicates the front of device
- Includes a base plate, two screw retainers, four mounting screws, a set screw, and a mounting disc
- 44.5 mm × 49.5 mm
- For installation instructions, see [Q45VA Bracket Assembly Quick Start Guide \(p/n 208986\)](#)

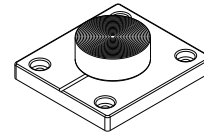

**BWA-Q45VA-CMSS**

- Includes a magnetic mounting bracket and four mounting screws
- 44.5 mm × 49.5 mm
- SmCo magnet with a 40 lb pull strength
- For use on flat or curved surfaces

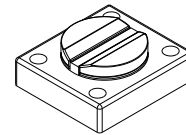

### Brackets/Installation for the Q45VAC

**BWA-Q45VAC-CMSS**

- Includes a magnetic mounting bracket and four mounting screws
- For use on flat or curved surfaces
- SmCo magnet with a 40 lb pull strength
- 44.5 mm × 54 mm; 15.6 mm thick

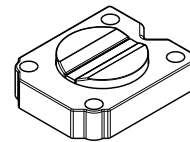

**BWA-Q45VAC-FESS**

- Includes a base plate, two screw retainers, four mounting screws, a set screw, and a mounting disc
- Mounts the device to a surface using two-part epoxy
- Alignment mark indicates the front of device
- 44.5 mm × 54 mm

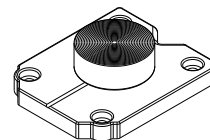

## Warnings

**Exporting Sure Cross® Radios.** It is our intent to fully comply with all national and regional regulations regarding radio frequency emissions. **Customers who want to re-export this product to a country other than that to which it was sold must ensure the device is approved in the destination country.** The Sure Cross wireless products were certified for use in these countries using the antenna that ships with the product. When using other antennas, verify you are not exceeding the transmit power levels allowed by local governing agencies. This device has been designed to operate with the antennas listed on Banner Engineering's website and having a maximum gain of 9 dBm. Antennas not included in this list or having a gain greater than 9 dBm are strictly prohibited for use with this device. The required antenna impedance is 50 ohms. To reduce potential radio interference to other users, the antenna type and its gain should be so chosen such that the equivalent isotropically radiated power (EIRP) is not more than that permitted for successful communication. Consult with Banner Engineering Corp. if the destination country is not on this list.

**IMPORTANT:** Please download the complete Wireless Q45VA/VAC All-in-One Sensor Note technical documentation, available in multiple languages, from [www.bannerengineering.com](http://www.bannerengineering.com) for details on the proper use, applications, Warnings, and installation instructions of this device.

**IMPORTANT:** Por favor descargue desde [www.bannerengineering.com](http://www.bannerengineering.com) toda la documentación técnica de los Wireless Q45VA/VAC All-in-One Sensor Note, disponibles en múltiples idiomas, para detalles del uso adecuado, aplicaciones, advertencias, y las instrucciones de instalación de estos dispositivos.

**IMPORTANT:** Veuillez télécharger la documentation technique complète des Wireless Q45VA/VAC All-in-One Sensor Note sur notre site [www.bannerengineering.com](http://www.bannerengineering.com) pour les détails sur leur utilisation correcte, les applications, les notes de sécurité et les instructions de montage.

### WARNING:



- **Do not use this device for personnel protection**
- Using this device for personnel protection could result in serious injury or death.
- This device does not include the self-checking redundant circuitry necessary to allow its use in personnel safety applications. A device failure or malfunction can cause either an energized (on) or de-energized (off) output condition.

### IMPORTANT:

- **Electrostatic discharge (ESD) sensitive device**
- ESD can damage the device. Damage from inappropriate handling is not covered by warranty.
- Use proper handling procedures to prevent ESD damage. Proper handling procedures include leaving devices in their anti-static packaging until ready for use; wearing anti-static wrist straps; and assembling units on a grounded, static-dissipative surface.

## Banner Engineering Corp Limited Warranty

Banner Engineering Corp. warrants its products to be free from defects in material and workmanship for one year following the date of shipment. Banner Engineering Corp. will repair or replace, free of charge, any product of its manufacture which, at the time it is returned to the factory, is found to have been defective during the warranty period. This warranty does not cover damage or liability for misuse, abuse, or the improper application or installation of the Banner product.

**THIS LIMITED WARRANTY IS EXCLUSIVE AND IN LIEU OF ALL OTHER WARRANTIES WHETHER EXPRESS OR IMPLIED (INCLUDING, WITHOUT LIMITATION, ANY WARRANTY OF MERCHANTABILITY OR FITNESS FOR A PARTICULAR PURPOSE), AND WHETHER ARISING UNDER COURSE OF PERFORMANCE, COURSE OF DEALING OR TRADE USAGE.**

This Warranty is exclusive and limited to repair or, at the discretion of Banner Engineering Corp., replacement. **IN NO EVENT SHALL BANNER ENGINEERING CORP. BE LIABLE TO BUYER OR ANY OTHER PERSON OR ENTITY FOR ANY EXTRA COSTS, EXPENSES, LOSSES, LOSS OF PROFITS, OR ANY INCIDENTAL, CONSEQUENTIAL OR SPECIAL DAMAGES RESULTING FROM ANY PRODUCT DEFECT OR FROM THE USE OR INABILITY TO USE THE PRODUCT, WHETHER ARISING IN CONTRACT OR WARRANTY, STATUTE, TORT, STRICT LIABILITY, NEGLIGENCE, OR OTHERWISE.**

Banner Engineering Corp. reserves the right to change, modify or improve the design of the product without assuming any obligations or liabilities relating to any product previously manufactured by Banner Engineering Corp. Any misuse, abuse, or improper application or installation of this product or use of the product for personal protection applications when the product is identified as not intended for such purposes will void the product warranty. Any modifications to this product without prior express approval by Banner Engineering Corp will void the product warranties. All specifications published in this document are subject to change; Banner reserves the right to modify product specifications or update documentation at any time. Specifications and product information in English supersede that which is provided in any other language. For the most recent version of any documentation, refer to: [www.bannerengineering.com](http://www.bannerengineering.com).

For patent information, see [www.bannerengineering.com/patents](http://www.bannerengineering.com/patents).