

Non-Ferrous Sensing Prox

E2CY

Non-Ferrous Detecting Proximity Sensor with Separate, Teaching Amplifier Features Simple Setup for Accurate, Reliable Sensing

- Detects only non-ferrous metals like aluminum, copper and brass
- Three teaching modes and one automatic mode for easy setup
- Three sensor heads to fit most mounting requirements
- Sensitivity can be easily monitored using indicators on amplifier

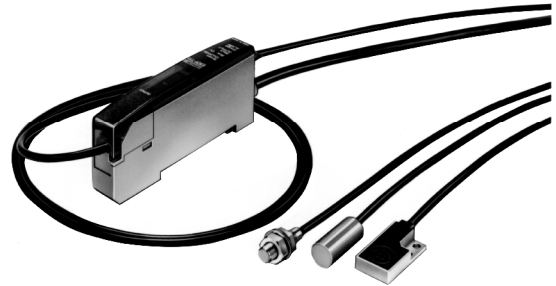

Ordering Information

■ SENSOR HEADS

Appearance	Shielded	Stable sensing distance	Part number
M5		1.5' mm	E2CY-X1R5A
8 dia.		2.0' mm	E2CY-C2A
Flat model		3.0' mm	E2CY-V3A

■ AMPLIFIER UNIT

Part number
E2CY-T11

Specifications

■ RATINGS/CHARACTERISTICS

Sensor Heads

Part number	E2CY-X1R5A	E2CY-C2A	E2CY-V3A
Target object	Non-ferrous metal		
Standard target object	Aluminum: 8 x 8 x 1 mm	Aluminum: 8 x 8 x 1 mm	Aluminum: 12 x 12 x 1 mm
Stable sensing distance	0 to 1.5 mm	0 to 2.0 mm	0 to 3.0 mm
Response frequency	40 Hz min. (with Amplifier Unit fine-tuned), 100 Hz min. (with Amplifier Unit set to NORM mode)		
Ambient temperature	Operating -10°C to 55°C (14°F to 131°F) with no icing		
Influence of temperature on sensing distance (at 23°C)	-10°C to 55°C (14°F to 131°F)	±15% max.	±10% max.
	0°C to 40°C (32°F to 104°F)	±10% max.	±15% max.

(This table continues on the next page.)

Specifications Table - continued from previous page

Part number		E2CY-X1R5A	E2CY-C2A	E2CY-V3A
Ambient humidity	Operating	35% to 95%		
Vibration resistance		Destruction: 10 to 500 Hz, 2.0-mm double amplitude or 150 m/s ² (approx. 15G) for 2 hours each in X, Y, and Z directions		
Shock resistance		Destruction: 500 m/s ² (approx. 50G) three times each in X, Y, Z directions		
Enclosure rating		IEC IP67		
Connecting cable length		Coaxial cable with a standard length of 3 m for high-frequency use		
Compensation range of cable length characteristic		0.5 to 5 m (See Note.)		
Material	Case	Stainless steel		Zinc die-cast
	Sensing surface	Heat-resistant ABS resin		
	Cable	Soft vinyl chloride		
Weight (packaged state)		Approx. 35 g (with 3 m cord)		
Accessories		M5 nut with toothed washer	---	M2 screw, hexagonal nut, spring washer, and flat washer

Note: When extending the cable, use a 1.5D-2V (equivalent to JIS C 3501) cable with characteristic impedance of 50 Ω.

Amplifier Unit

Supply voltage		12 to 24 VDC ± 10%, ripple (p-p): ±10% max.	
Current consumption		40 mA max.	
Sensing distance adjustment range		10% min. of stable sensing distance	
Adjustment method		Teaching	
Differential travel		10% max. of sensing distance in FINE mode. 15% max. of sensing distance in NORM mode.	
Response time		Refer to the response frequency of the Sensor Head in use.	
Control output		NPN open collector output of 100 mA max. with a max. residual voltage of 1 V	
Self-diagnostic output		NPN open collector output of 100 mA max. with a max. residual voltage of 1 V	
Circuit protection		Reverse polarity, surge voltage, and load short-circuit (for both control output and diagnosis output)	
Cable length		2 m, pull-out cable	
Cable length compensation		Freely cut or extended within a range between 0.5 and 5 m	
Indicators		Operation indicator (orange) Excess gain level indicators (ON in green with sensing object in proximity and ON in orange with no sensing object in proximity) Fine-tuning indicator (green)	
Ambient temperature	Operating	-10°C to 55°C (14°F to 131°F) with no icing	
Ambient humidity	Operating	35 to 85%	
Influence of temperature on sensing distance (at 23°C)		±10% max. -10°C to 55°C (14°F to 131°F)	
Insulation resistance		50 MΩ min. (at 500 VDC) between current carrying parts and case	
Dielectric strength		1,000 VAC (50/60 Hz) for 1 min between current carrying parts and case	
Vibration resistance		Destruction: 10 to 150 Hz, 1.5-mm double amplitude or 100 m/s ² (approx. 10G) for 2 hours each in X, Y, and Z directions	
Shock resistance		Destruction: 300 m/s ² (approx. 30G) for 3 hours each in X, Y, and Z directions	
Degree of protection		IEC IP50 with the sensor cable and protective cover attached	
Material	Case	PTB resin	
	Cover	Polycarbonate	
Teaching monitor function		Orange and green indicators shared by operation and excess gain indication	
Output status		Normally open or normally closed selectable	
Weight (packaged state)		Approx. 75 g (with 2-m cable)	
Accessories		Mounting brackets and instruction sheet	

Operation

■ OUTPUT CIRCUIT

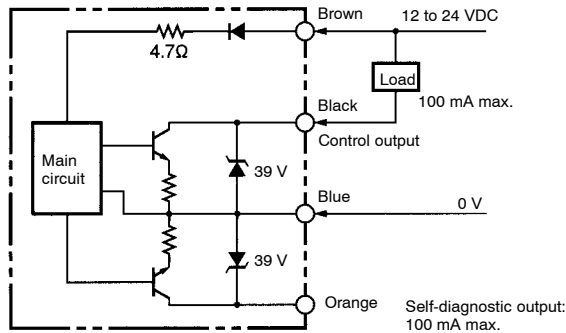

■ SENSITIVITY ADJUSTMENTS

Sensitivity adjustment is performed with or without a target object by setting the Sensor to the maximum sensing distance. The distance can be set by using any of the following four methods.

Types of Sensing Adjustments and Applications

No.	Distance adjustment method	Application	Operation mode selector
1	Teaching without sensing object	The E2CY is used as a normal proximity sensor.	T
2	Teaching with or without the sensing object	<ul style="list-style-type: none"> The E2CY is used for detecting the difference in target object level. The E2CY is used for discriminating types of target objects. The E2CY is used for discriminating the distance between the sensing surface and target objects located within a certain range. 	
3	Positioning teaching	<ul style="list-style-type: none"> Object positioning is required. The designation of sensor-ON point is required. 	
4	The distance is adjusted automatically	The E2CY is used as a normal proximity sensor.	AUTO

Note: All teaching methods can eliminate the influence of surrounding metal objects.

T Mode

Teaching Without Target Object

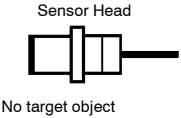
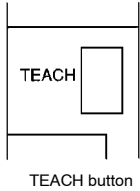
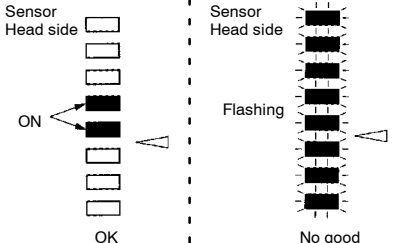
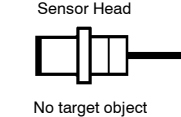
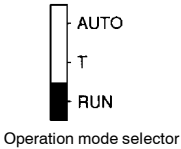
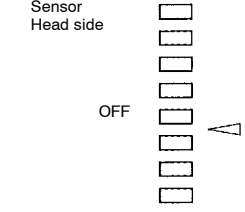
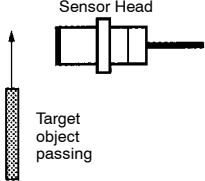
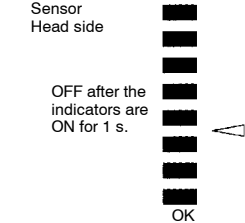
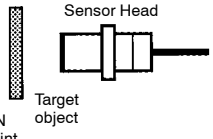
Step 1	<p>Set the operation mode selector to T.</p> <p>Press the TEACH button once with no target object located.</p> <hr/> <p>If all the indicators flash, press the TEACH button again.</p>	<p>Status of target object</p>  <p>No target object</p>	<p>Control panel</p>  <p>TEACH button</p>	<p>Indicators (Excess gain level indicators)</p> 
<p>Step 2</p> <p>Set the operation mode selector to RUN.</p>	<p>Status of target object</p>  <p>No target object</p>	<p>Control panel</p>  <p>Operation mode selector</p>	<p>Indicators (Excess gain level indicators)</p> 	
<p>Step 3</p> <p>Move the target object so that it passes through the sensing position once.</p>	<p>Status of target object</p>  <p>Target object passing</p>	<p>Control panel</p> <p>No switches are operated.</p>	<p>Indicators (Excess gain level indicators)</p> 	
<p>In Operation</p> <p>---</p>	<p>Sensitivity setting position</p>  <p>ON point</p> <p>The ON point is set to a distance that is approximately 1.2 times larger than the distance between the position where the sample sensing object passes and the sensing surface of the Sensor Head.</p>	<p>---</p>	<p>---</p>	

Note: After the E2CY is set to RUN mode, approximately 1.5 s will be required until the sensitivity is set from the moment the first target object passes the sensing position. Therefore, move the next target object so that it passes through the sensing position 1.5 s after the first target object passes the sensing position. Once the sensitivity adjustment is made, it will operate under the normal response frequency.

Teaching With and Without Target Object (Level Difference Detection)

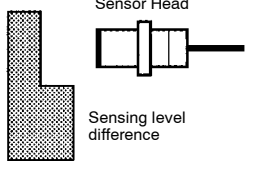
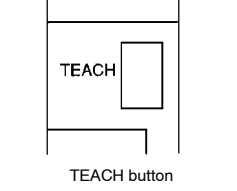
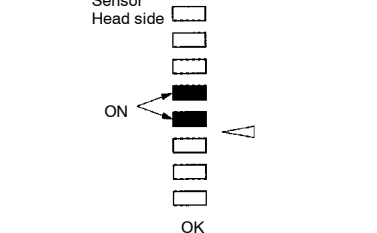
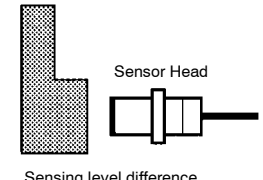
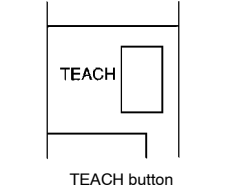
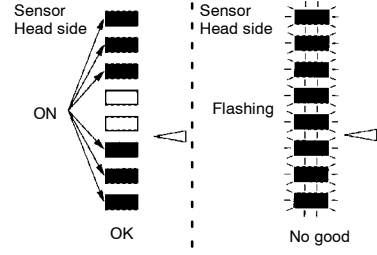
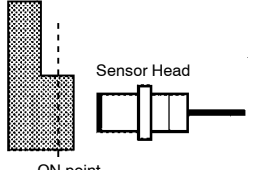
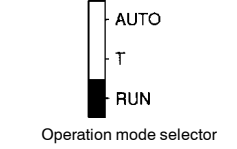
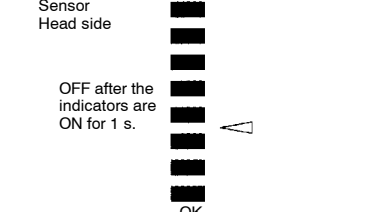
Step 1		Status of target object	Control panel	Indicators (Excess gain level indicators)
<p>Set the operation mode selector to T.</p> <p>Press the TEACH button after locating one of the sensing levels in front of the sensing surface.</p>		 <p>Sensor Head</p> <p>Sensing level difference</p>	 <p>TEACH</p> <p>TEACH button</p>	 <p>Sensor Head side</p> <p>ON</p> <p>OK</p>
<p>Press the TEACH button after locating the other sensing level in front of the sensing surface.</p> <p>If all the indicators flash, repeat from step 1. Or, change the Sensor Head position or set the resolution selector to FINE and then repeat from step 1.</p>		 <p>Sensor Head</p> <p>Sensing level difference</p>	 <p>TEACH</p> <p>TEACH button</p>	 <p>Sensor Head side</p> <p>ON</p> <p>OK</p> <p>Flashing</p> <p>No good</p>
<p>Set the operation mode selector to RUN.</p>		<p>Sensitivity setting position</p>  <p>Sensor Head</p> <p>ON point</p> <p>The ON point is set in the middle of the two levels.</p>	 <p>AUTO</p> <p>T</p> <p>RUN</p> <p>Operation mode selector</p>	<p>Indicators (Excess gain level indicators)</p>  <p>Sensor Head side</p> <p>OFF after the indicators are ON for 1 s.</p> <p>OK</p>

Note: 1. The threshold level can be set to the same position by locating the target object at either one of the edges of the sensing range when performing steps 1 and 2.

2. After setting the mode to RUN, confirm that all eight excess gain level indicators are ON.

Teaching With and Without Target Object (Located within Certain Range)

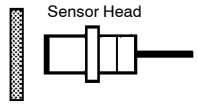
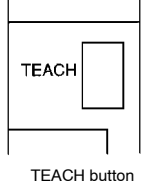
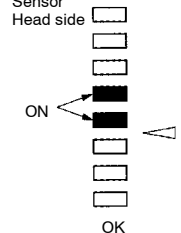
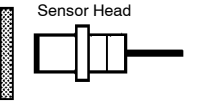
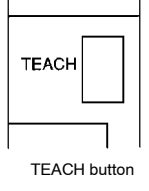
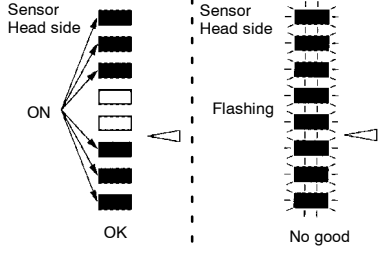
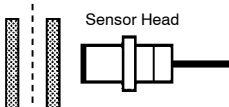
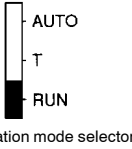
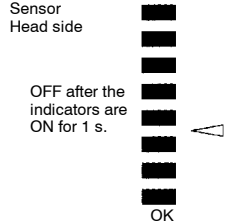
Step 1		Status of target object	Control panel	Indicators (Excess gain level indicators)
	<p>Set the operation mode selector to T.</p> <p>Press the TEACH button after locating the target object at one edge of the sensing range.</p>	 <p>Sensing object at a certain position</p>	 <p>TEACH button</p>	 <p>OK</p>
Step 2	<p>Press the TEACH button after locating the other sensing level in front of the sensing surface.</p> <p>If all the indicators flash, repeat from step 1. Or, change the Sensor Head position or set the resolution selector to FINE and then repeat from step 1.</p>	 <p>Sensing object at a certain position</p>	 <p>TEACH button</p>	 <p>OK</p> <p>No good</p>
Step 3	<p>Set the operation mode selector to RUN.</p>	<p>Sensitivity setting position</p>  <p>ON point The ON point is located in the middle of the edges.</p>	 <p>Operation mode selector</p>	<p>Indicators (Excess gain level indicators)</p>  <p>OK</p>

- Note: 1. The threshold level can be set to the same position by locating the target object at either one of the edges of the sensing range when performing steps 1 and 2.
2. After setting the mode to RUN, confirm that all eight excess gain level indicators are ON.

Positioning Teaching

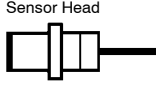
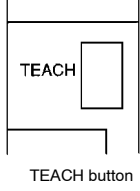
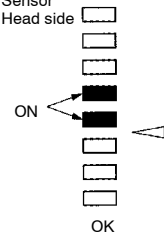
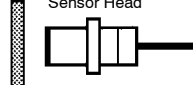
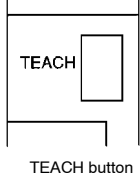
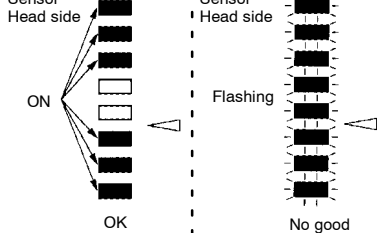
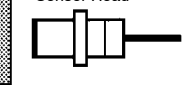
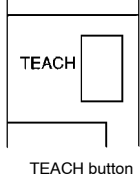
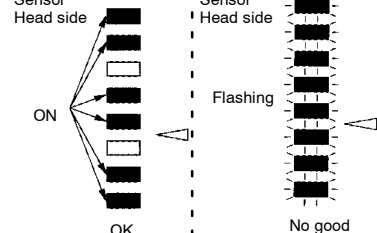
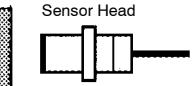
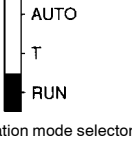
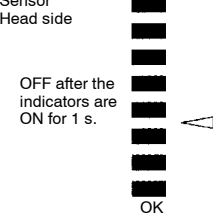
Step 1	Status of target object	Control panel	Indicators (Excess gain level indicators)
<p>Set the operation mode selector to T.</p> <p>Press the TEACH button once with no target object located.</p>	 <p>Sensor Head</p> <p>No target object</p>	 <p>TEACH button</p>	 <p>Sensor Head side</p> <p>ON</p> <p>OK</p>
<p>Press the TEACH button once after locating the target object at the desired teaching position.</p> <p>If all the indicators flash, repeat from step 1.</p>	 <p>Sensor Head</p> <p>Target object at a certain position</p>	 <p>TEACH button</p>	 <p>Sensor Head side</p> <p>ON</p> <p>Flashing</p> <p>OK</p> <p>No good</p>
<p>Press the TEACH button once with the target object located at the same position.</p> <p>If all the indicators flash, repeat from step 1.</p>	 <p>Sensor Head</p> <p>Target object at a certain position</p>	 <p>TEACH button</p>	 <p>Sensor Head side</p> <p>ON</p> <p>Flashing</p> <p>OK</p> <p>No good</p>
<p>Set the operation mode selector to RUN.</p>	 <p>Sensor Head</p> <p>ON point</p> <p>The ON-point is set at the teaching position.</p>	 <p>AUTO</p> <p>T</p> <p>RUN</p> <p>Operation mode selector</p>	 <p>Sensor Head side</p> <p>OFF after the indicators are ON for 1 s.</p> <p>OK</p>

AUTO Mode

This mode is used for adjusting the target distance to its maximum without using any target object.

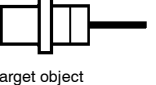
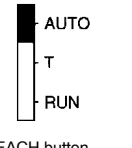
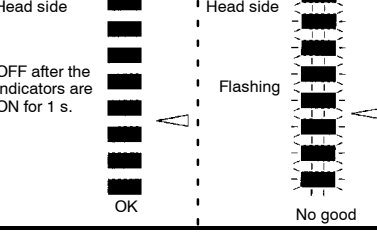
Set the operation mode selector to AUTO with no target object located at the sensing distance.	Status of target object	Control panel	Indicators (Excess gain level indicators)
	 <p>Sensor Head</p> <p>No target object</p> <p>The sensing distance is automatically set to 80% to 110% of the stable sensing distance of the E2CY.</p>	 <p>AUTO</p> <p>T</p> <p>RUN</p> <p>TEACH button</p>	 <p>Sensor Head side</p> <p>OFF after the indicators are ON for 1 s.</p> <p>OK</p> <p>No good</p>

Note: If the operation mode selector is set to AUTO when the E2CY is turned ON, the E2CY will make sensitivity adjustments automatically. To maintain the sensitivity after adjustment, be sure to set the operation mode selector to RUN.

Engineering Data

■ OPERATING RANGE (TYPICAL)

E2CY-X1R5A

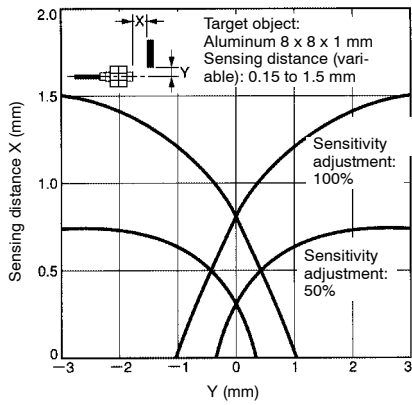

E2CY-C2A

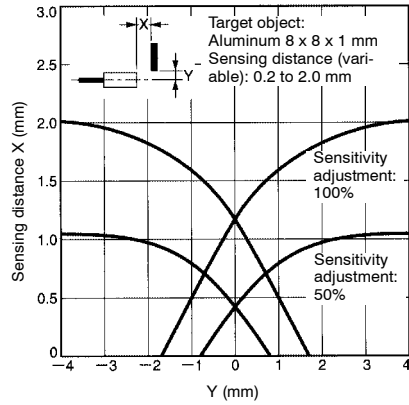

E2CY-V3A

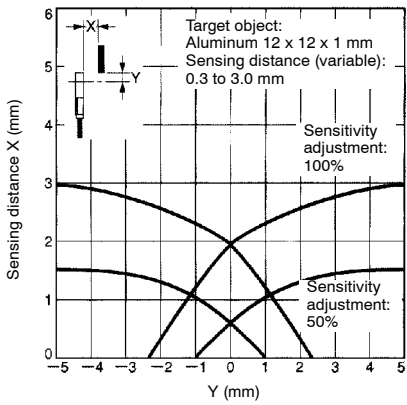

■ SENSING DISTANCE VS. SENSING OBJECT SIZE AND MATERIAL (TYPICAL)

E2CY-X1R5A

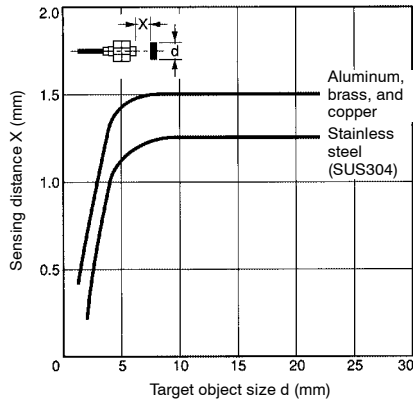

E2CY-C2A

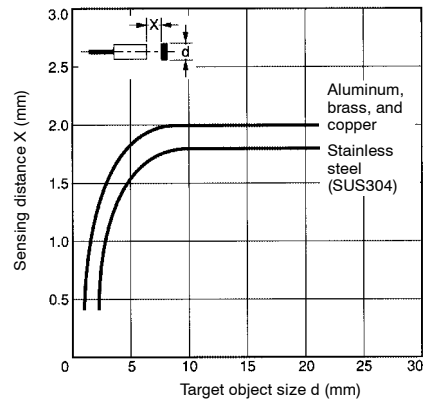

E2CY-V3A

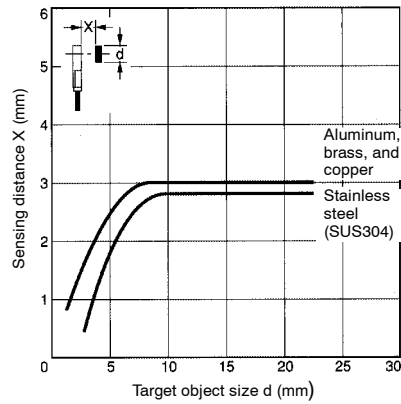

■ TEMPERATURE INFLUENCE (TYPICAL)

E2CY-X1R5A

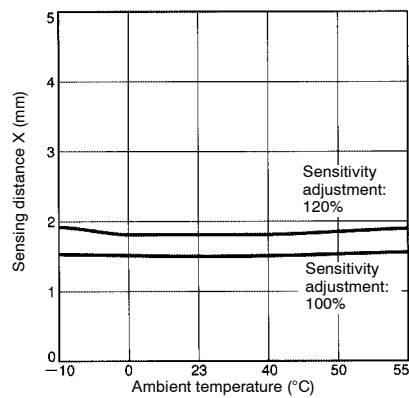

E2CY-C2A

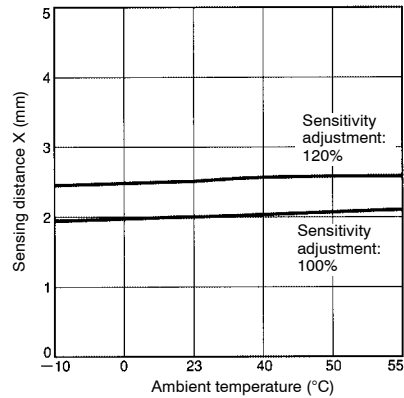

E2CY-V3A

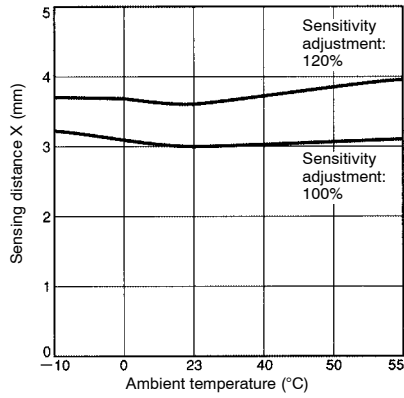

Dimensions

Unit: mm (inch)

■ SENSOR HEADS

E2CY-X1R5A

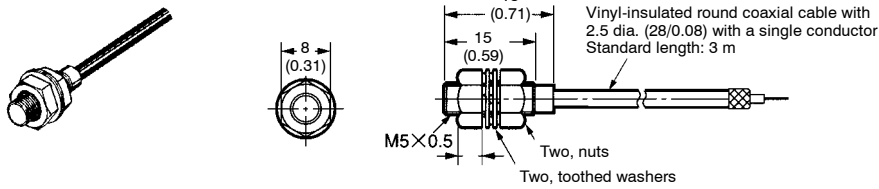

E2CY-C2A

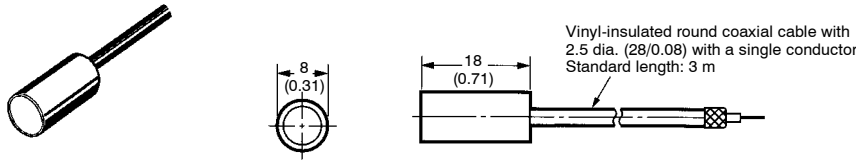

E2CY-V3A

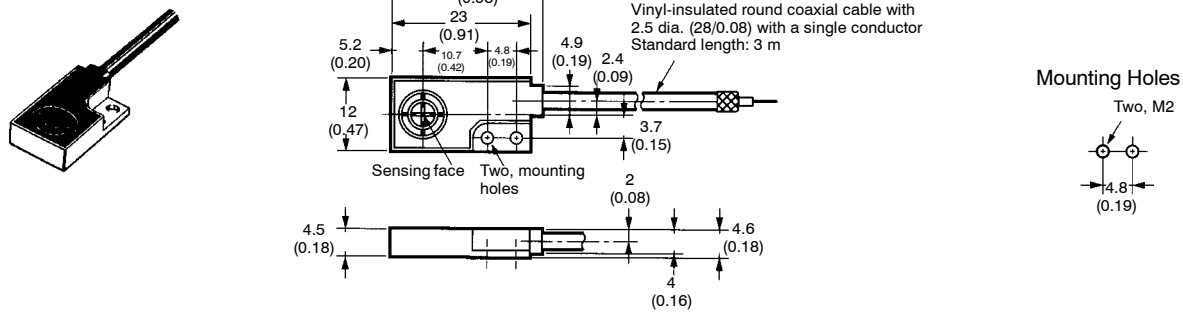

■ AMPLIFIER UNIT

E2CY-T11

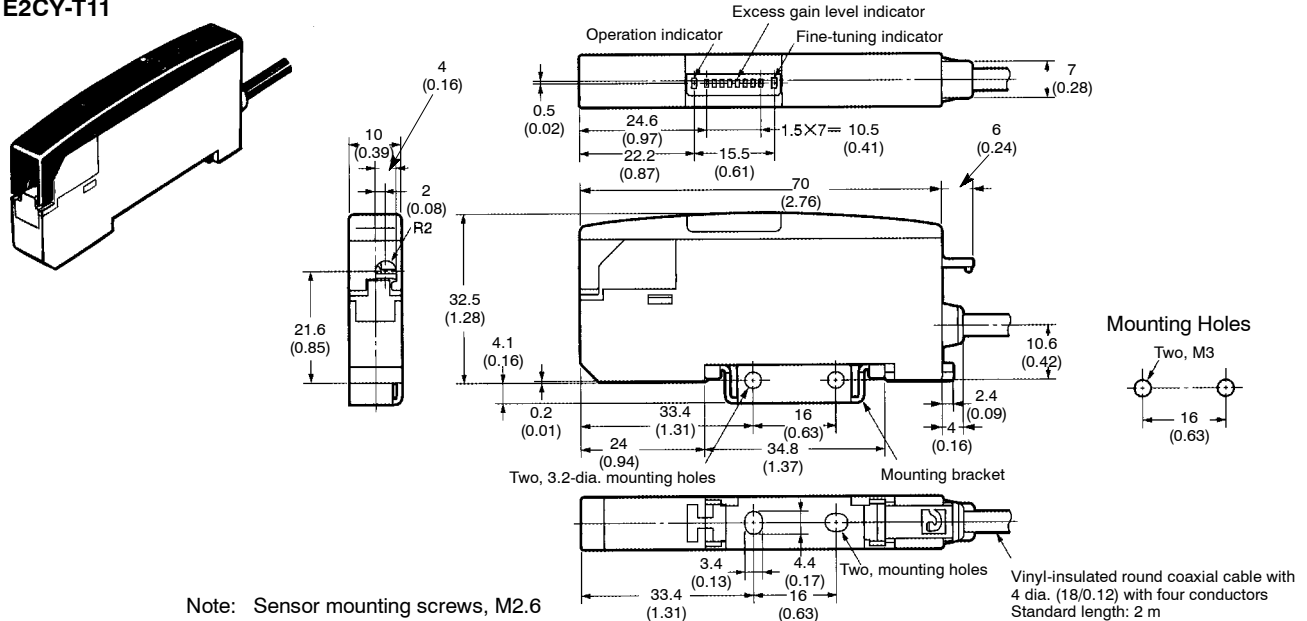

Note: Sensor mounting screws, M2.6

Nomenclature

■ CONTROL PANEL OF AMPLIFIER UNIT

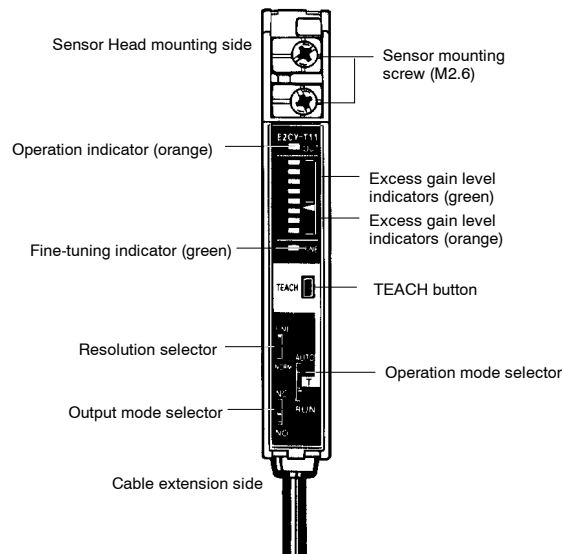

Operation Mode Selector

AUTO Mode: The sensitivity is automatically adjusted within a range of approximately 80% to 110% of the rated sensing distance.

T Mode: This mode is used when adjusting the sensitivity of the Sensor. (The output transistor does not operate in this mode.)

RUN Mode: This mode is used for the normal operation of the Sensor.

Resolution Selector

If the E2CY often has a teaching error when detecting fine-tuning differences, set the resolution selector to FINE.

The response speed will drop but improvement in the sensing accuracy of the E2CY can be expected.

Output Mode Selector

Used to select the transistor mode (NPN open collector output).

NO: Normally open output
(Output transistor will turn ON if a sensing object is present.)

NC: Normally closed output
(Output transistor will turn ON if a sensing object is not present.)

■ SELF-DIAGNOSTIC FUNCTION

The output transistor of self-diagnostic output will turn ON in the following cases.

1. **Sensor cable disconnection**

The self-diagnostic output will turn ON approximately 105 ms after the sensor cable disconnects.

2. **Sensor cable short-circuit**

The self-diagnostic output will turn ON approximately 105 ms after the sensor cable short-circuits.

3. **Control output short-circuiting**

The self-diagnostic output will turn ON if excessive current flows to the load due to load wire short-circuiting.

4. **Internal memory error**

When the E2CY is turned ON in RUN or TEACH mode, the self-diagnostic output will turn ON if the teaching status of the E2CY is not stored properly in the internal memory.

INDICATORS

Operation Indicator (Orange)

The operating indicator will turn ON when the control output is ON.

Excess Gain Level Indicators (Green and Orange)

The excess gain level indicators will be ON according to the distance of the target object as shown below.

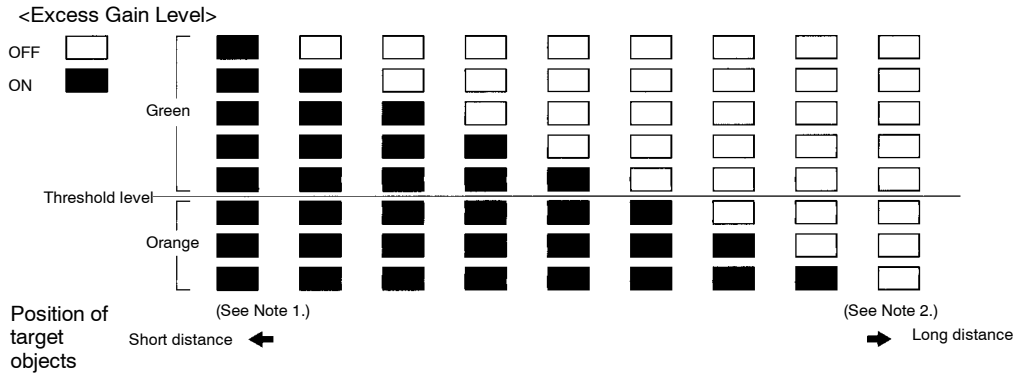

Note: 1. All indicators will be ON if the target object is at a position of approximately 80% of the preset sensing distance.

2. All indicators will be OFF at a position of approximately 110% of the preset sensing distance.

Installation

CONNECTION

Connection of Sensor Head and Amplifier Unit

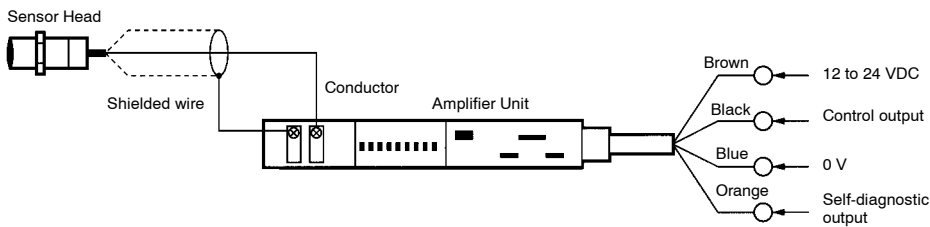

Precautions

■ AVOID DAMAGE TO THE E2CY

Power Supply Voltage

Do not impose voltage exceeding the rated voltage range or 100 VAC on the E2CY.

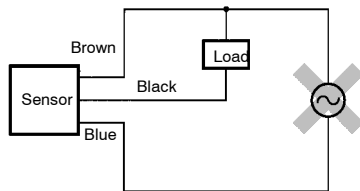

Incorrect Wiring

Be sure to observe correct polarity when connecting the power supply and load to the E2CY.

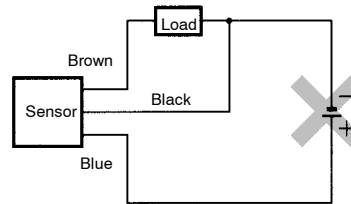

Load Short-circuit

Do not short-circuit the load.

The load short-circuit protection function is triggered provided that power within the rated voltage range is supplied to the E2CY without a mistake in polarity.

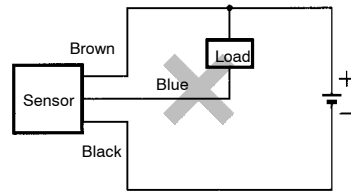
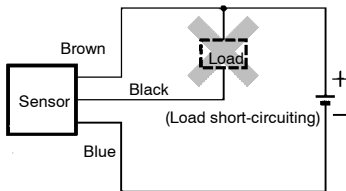

SELF-DIAGNOSTIC OUTPUT AND INDICATORS

If one of the following errors result, the user can find the errors using the self-diagnostic output and indicators of the E2CY. If the self-diagnostic output line is short-circuited, however, self-diagnostic output will not be available.

Error indication	Flashing OUT Flashing Flashing FINE	Flashing OUT Flashing FINE	OUT Flashing Flashing FINE	OUT Flashing FINE
Cause of error	<ul style="list-style-type: none"> The Sensor Head cable is disconnected. The Sensor Head cable is short-circuited. The Sensor Head is not connected properly. 	<ul style="list-style-type: none"> The load is short-circuited. 	<ul style="list-style-type: none"> The self-diagnostic output line is short-circuited. 	<ul style="list-style-type: none"> Proper teaching has not completed. The internal memory element is broken.
Remedy	<ul style="list-style-type: none"> Make sure that the Sensor Head is connected properly. If there is a Sensor Head cable disconnection, repair the disconnected cable portion or replace the Sensor Head. <p>Note: A similar problem will occur if ferrous metal, such as iron, is located close to the E2CY.</p>	<ul style="list-style-type: none"> Correctly connect the load to the control output. 	<ul style="list-style-type: none"> Correctly connect the self-diagnostic output line. 	<ul style="list-style-type: none"> Perform the teaching operation of the E2CY again. Replace the E2CY amplifier.

TIGHTENING TORQUE

Do not tighten the nut of the E2CY-□ excessively. Be sure to tighten the nut with a toothed washer to the following torque.

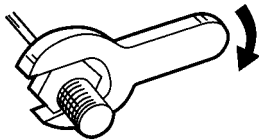

Model	Torque
E2CY-X1R5A	1.0 N • m (10 kgf • cm)

Note: The above applies to a nut used with a toothed washer.
If a set screw is used for mounting a screwless, column model, make sure that the tightening torque does not exceed 0.2 N • m (2 kgf • cm).

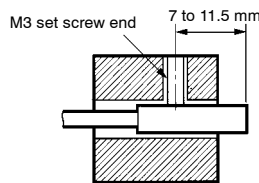

INFLUENCE OF SURROUNDING METAL

If the Sensor is embedded, be sure to separate the Sensor from surrounding metal objects as shown in the following illustration.

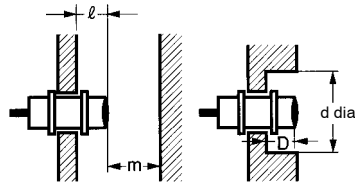

Model	Distance (mm)			
	ℓ	d	D	m
E2CY-X1R5A	0	5	0	9
E2CY-C2A	0	8	0	15
E2CY-V3A	0	12	0	18

The E2CY-V3A can be embedded in metal with the sensing surface at the same level as the metal surface.

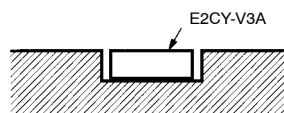

MUTUAL INTERFERENCE

If more than one Sensor is positioned face-to-face or in parallel, be sure to maintain enough space, as provided in the following table, between adjacent Sensors to suppress mutual interference.

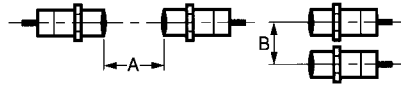

Model	Distance (mm)	
	A	B
E2CY-X1R5A	20	15
E2CY-C2A	20	15
E2CY-V3A	30	12

AMPLIFIER UNIT MOUNTING AND REMOVAL

Mounting

- Place the front part of the Amplifier Unit on the mounting bracket provided with the E2CY or the DIN track so that the front part will engage with the mounting bracket or DIN track.
- Press the rear part of the Amplifier Unit onto the mounting bracket or DIN track.

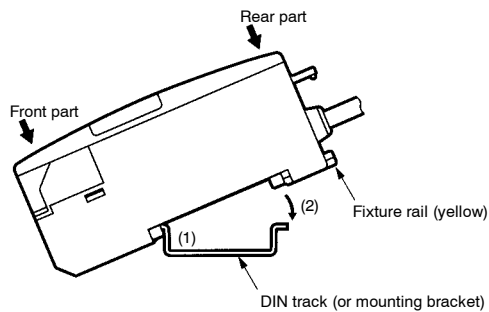

If the Amplifier Unit is side-mounted to the bracket provided, secure it using M3 screws with flat washers (6 mm in dia., or less).

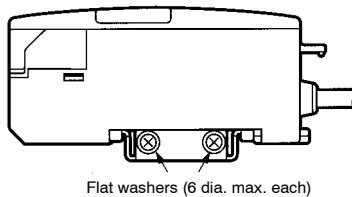

Removal

Press the Amplifier Unit in the direction shown by arrow (3) in the following illustration and lift up the fiber insertion part of the Amplifier Unit in the direction shown by arrow (4), so the Amplifier Unit can be removed easily. No screwdriver is required to remove the Amplifier Unit.

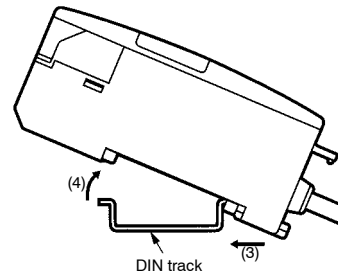

TEACHING

Make sure that the Sensor is in operating condition before making sensitivity adjustments.

PROCESSING THE SENSOR CABLE ENDS

When cutting or extending the cable, the end of the sensor cable connected to the E2CY-□ must be processed as shown in the following illustration.

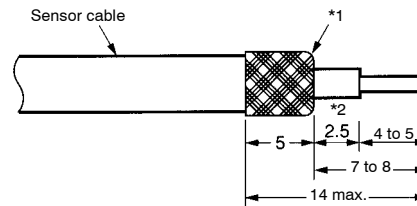

Note:*1. Be sure to turn over the braided shield so that none of its thin wires are left.

*2. Make sure that a minimum of 2.5 mm of cable insulation is maintained.

POWER ON OPERATION

- The E2CY will be ready for sensing within 50 ms after the power is turned ON.
- When the E2CY and load are connected to different power supplies, you must turn ON the power supply to the E2CY first.

EFFECT OF HIGH-FREQUENCY ELECTRO-MAGNETIC FIELD

If the E2CY is located near a high-frequency generation unit or transceiver, it may be affected by such a unit and result in malfunction.