

1A, 200V - 600V Super Fast Bridge Rectifier

FEATURES

- AEC-Q101 qualified available
- Ideal for automated placement, for compact PCB design
- High surge current capability
- Super fast reverse recovery time for high frequency
- Negligible leakage current
- Moisture sensitivity level: level 1, per J-STD-020
- RoHS Compliant
- Halogen-free according to IEC 61249-2-21

APPLICATIONS

- Switching mode power supply (SMPS)
- Adapters
- Lighting application

MECHANICAL DATA

- Case: ABS
- Molding compound meets UL 94V-0 flammability rating
- Terminal: Matte tin plated leads, solderable per J-STD-002
- Meet JESD 201 class 2 whisker test
- Polarity: As marked
- Weight: 0.090g (approximately)

KEY PARAMETERS		
PARAMETER	VALUE	UNIT
I_F	1	A
V_{RRM}	200 - 600	V
I_{FSM}	40	A
$T_{J\ MAX}$	150	°C
Package	ABS	
Configuration	Quad	

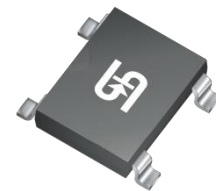

ABS

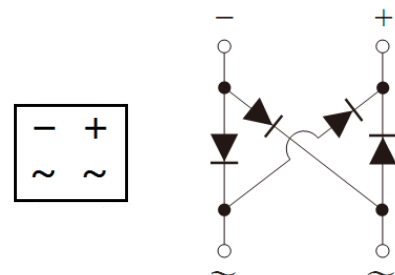

ABSOLUTE MAXIMUM RATINGS ($T_A = 25^\circ\text{C}$ unless otherwise noted)					
PARAMETER	SYMBOL	EABS1D	EABS1G	EABS1J	UNIT
Marking code on the device		EABS1D	EABS1G	EABS1J	
Repetitive peak reverse voltage	V_{RRM}	200	400	600	V
Reverse voltage, total rms value	$V_{R(RMS)}$	140	280	420	V
Forward current	I_F	1			A
Peak forward surge current, 8.3ms single half sine-wave superimposed on rated load	I_{FSM}	40			A
Rating for fusing ($t < 8.3\text{ms}$)	I^2t	6.64			A^2s
Junction temperature	T_J	- 55 to +150			°C
Storage temperature	T_{STG}	- 55 to +150			°C

THERMAL PERFORMANCE			
PARAMETER	SYMBOL	TYP	UNIT
Junction-to-lead thermal resistance	$R_{\theta JL}$	25	°C/W
Junction-to-ambient thermal resistance	$R_{\theta JA}$	80	°C/W

ELECTRICAL SPECIFICATIONS ($T_A = 25^\circ\text{C}$ unless otherwise noted)						
PARAMETER		CONDITIONS	SYMBOL	TYP	MAX	UNIT
Forward voltage per diode ⁽¹⁾	EABS1D	$I_F = 1\text{A}, T_J = 25^\circ\text{C}$	V_F	-	0.95	V
	EABS1G			-	1.20	V
	EABS1J			-	1.70	V
Reverse current @ rated V_R per diode ⁽²⁾	$T_J = 25^\circ\text{C}$		I_R	-	1	μA
	$T_J = 125^\circ\text{C}$			-	200	μA
Reverse recovery time	$I_F = 0.5\text{A}, I_R = 1.0\text{A}$ $I_{rr} = 0.25\text{A}$		t_{rr}	-	35	ns

Notes:

1. Pulse test with $PW = 0.3\text{ms}$
2. Pulse test with $PW = 30\text{ms}$

ORDERING INFORMATION		
ORDERING CODE ⁽¹⁾⁽²⁾	PACKAGE	PACKING
EABS1x	ABS	5,000 / Tape & Reel
EABS1xH	ABS	5,000 / Tape & Reel

Notes:

1. "x" defines voltage from 200V(EABS1D) to 600V(EABS1J)
2. "H" means AEC-Q101 qualified

CHARACTERISTICS CURVES

($T_A = 25^\circ\text{C}$ unless otherwise noted)

Fig.1 Forward Current Derating Curve

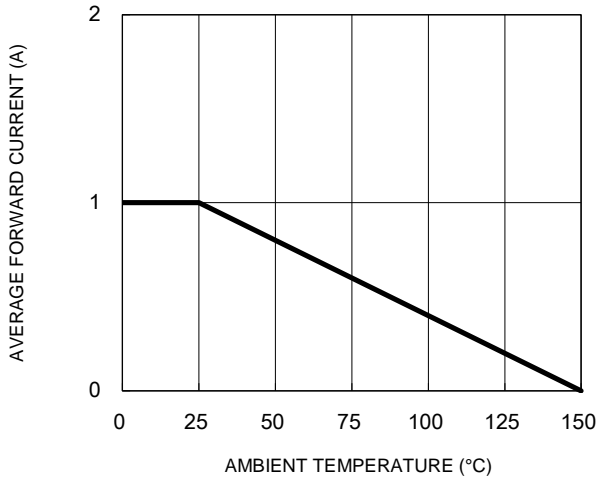

Fig.2 Typical Junction Capacitance

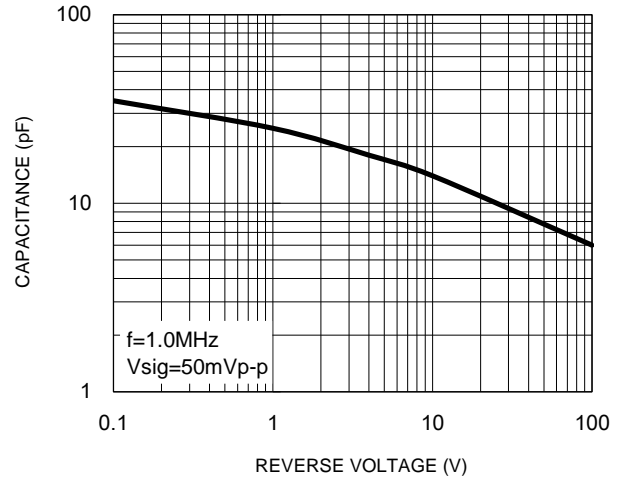

Fig.3 Typical Reverse Characteristics

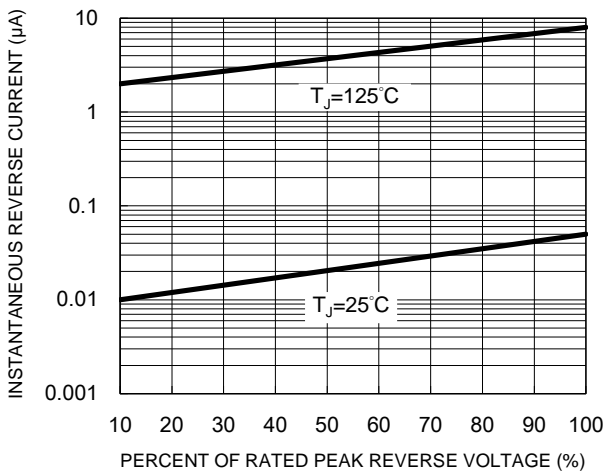

Fig.4 Typical Forward Characteristics

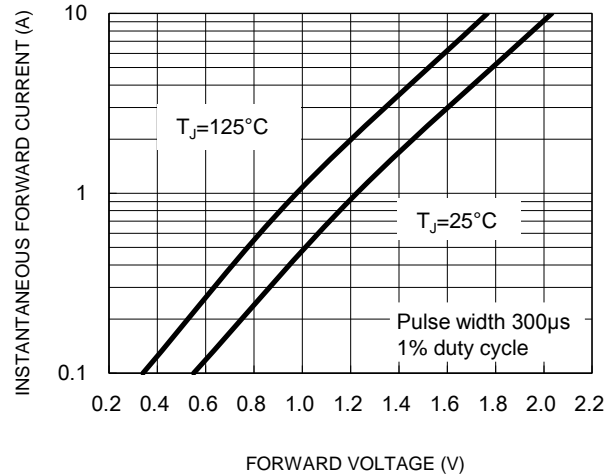
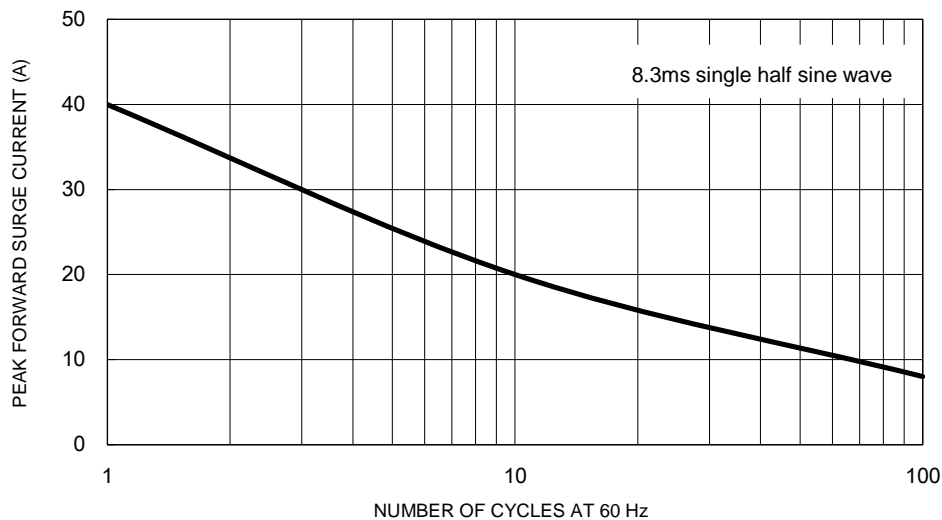
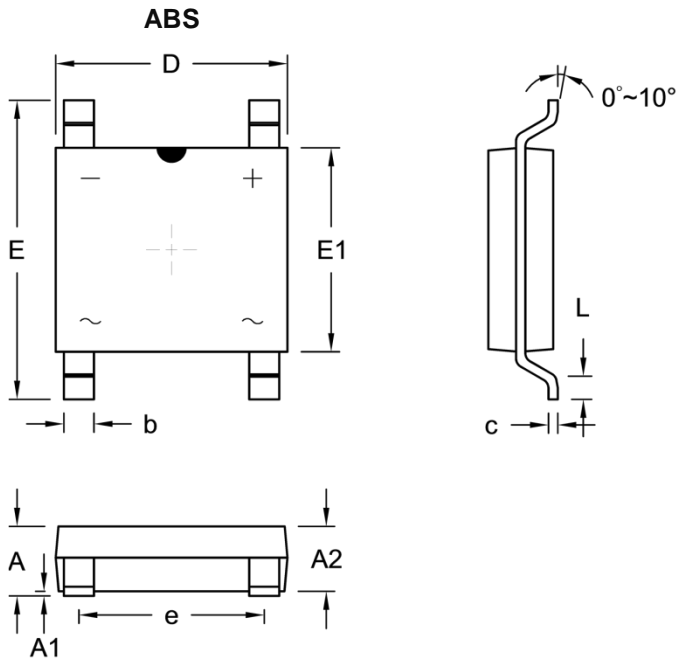

Fig.5 Maximum Non-Repetitive Forward Surge Current



PACKAGE OUTLINE DIMENSIONS



DIM.	Unit (mm)		Unit (inch)	
	Min.	Max.	Min.	Max.
A	1.40	1.60	0.055	0.063
A1	0.05	0.15	0.002	0.006
A2	1.35	1.45	0.053	0.057
b	0.60	0.70	0.024	0.028
c	0.15	0.25	0.006	0.010
D	4.90	5.10	0.193	0.201
E	6.25	6.65	0.246	0.262
E1	4.30	4.50	0.169	0.177
e	3.90	4.10	0.154	0.161
L	0.30	0.70	0.012	0.028

SUGGESTED PAD LAYOUT

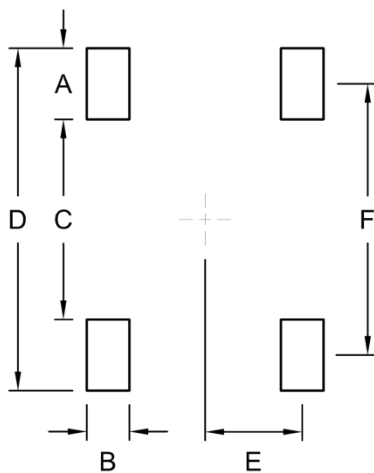

Symbol	Unit (mm)	Unit (inch)
A	1.50	0.059
B	0.90	0.035
C	4.22	0.166
D	7.22	0.284
E	2.05	0.081
F	5.72	0.225

MARKING DIAGRAM

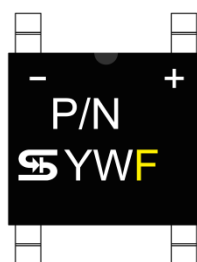

P/N = Marking Code
 YW = Date Code
 F = Factory Code