



EAR-001 & EAR-002 MODELS

SIL3 PLe SAFETY ENCODER SIGNAL SPLITTERS

Introduction

The Functional Safety splitter is a certified data interface that is designed to integrate into a safety loop.

Its construction allows it to easily integrate an encoder with safety motion controllers, while also providing a secondary set of data outputs for a standard motion controller. The primary signal from the splitter is 100% compatible with BEI Sensors/Sensata Safety motion controllers and safety relays. While the secondary signal (or repeater) provides encoder signals for an additional industrial grade (non-Functional Safety) motion controller (drive, display, PLC, etc.)



Features

- Usable with standard and Safety encoders
- Suitable for simultaneous safe and non-safe motor feedback connections
- TTL/RS422, HTL or sine 1Vpp encoder interfaces
- Safe output: same as connected encoder interface
- Non-safe output: TTL/RS422 or HTL user selectable
- Power supply for encoders: 5Vdc or 11-30Vdc user selectable

Applications

- Automated machine tools
- Safety lock-out systems
- Robotic assembly
- Conveyor and web-based systems (packaging, inspection, cartonizing)

SPECIFICATIONS

Mechanical

	EAR-001	EAR-002
Housing Material	Polyamid, red color	
Dimensions (W x H x D)	22.5 x 108 x 114.5mm	
Fixing mode	DIN rail	
Weight	140g	

Electrical

	EAR-001	EAR-002
Splitter power supply +Vin	11-30Vdc  250mA (*)	
Encoder power supply	Selectable : +Vin or 5Vdc, 200mA max.	+Vin, 200mA max.
Max encoder frequency	300kHz	
Encoder input	TTL/RS422 or sine 1Vpp	HTL
Safe output (Direct encoder signals transmission)	Same as interfaced encoder	HTL
Secondary output (Not safety rated)	Selectable: TTL/RS422 or HTL	
Encoder input connection	Terminal blocks	

Secondary output connection	Terminal blocks
Safe output connection	RJ45 connector

(*) Device must be supplied by a Class 2 LPS or SELV/PELV limited energy source ≤60V.

Functional Safety Parameters

The splitter does not contribute to the overall failure rate (safety chain) since it has no known failure modes or diagnostics. The safety-related parameters are dependent on the connected encoder and safety controller and can reach up to SIL 3 / PLe Cat 4.

Environmental & Standards Conformity

Protection (EN 60529)	IP20
Humidity (EN 60068-2-38)	93% @ 65°C for electronics (Housing may show mechanical deformations when cumulating high humidity with high temperature cycles)
Shock (EN60068-2-27)	300m.s ⁻² (during 11 ms)
Vibration (EN60068-2-6)	Amplitude 3.5 mm or acceleration 50 m.s ⁻² (10 ... 200 Hz)
Operating temperature	-20°C to +65°C
Storage temperature	-20°C to +70°C
EMC Immunity Test	EN 61000-6-2:2016, increased levels in accordance with IEC 62061
EMC Emission Test	EN 61000-6-4:2018, increased levels in accordance with IEC 62061
Isolation	500 Veff
Functional safety	IEC 61508
	IEC 62061
	ISO 13849-1
	IEC 61800-5-2
Splitters usable up to SIL3 / PLe with specific requirements, see safety user manual for details.	

Electrical Connections

RJ45 Wiring (SAFE output)		
PIN	SIGNAL	EAR-001 & EAR-002 FUNCTION
1	+V ENCODER	Encoder power supply +V output for monitoring purpose
2	0V	Encoder power supply 0V
3	N/C	Reserved
4	A ENCODER	A signal - SAFE output
5	A/ ENCODER	A/ signal - SAFE output
6	N/C	Reserved
7	B ENCODER	B signal - SAFE output
8	B/ ENCODER	B/ signal - SAFE output

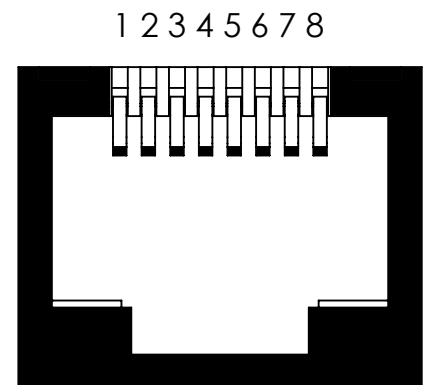

Terminal blocks wiring			
PIN	SIGNAL	EAR-001 FUNCTION	EAR-002 FUNCTION
1	+Vin		Splitter power supply : +24Vdc
2	Z SECONDARY		Z signal - SECONDARY output
3	Z/ SECONDARY		Z/ signal - SECONDARY output
4	0V		Splitter power supply ground
5	+V ENCODER		Encoder power supply output
6	Z ENCODER		Z signal - ENCODER input
7	Z/ ENCODER		Z/ signal - ENCODER input
8	0V ENCODER		Encoder power supply: 0V (internally connected to PIN 4)
9	A SECONDARY		A signal - SECONDARY output
10	A/ SECONDARY		A/ signal - SECONDARY output
11	B SECONDARY		B signal - SECONDARY output
12	B/ SECONDARY		B/ signal - SECONDARY output
13	A ENCODER		A signal - ENCODER input
14	A/ ENCODER		A/ signal - ENCODER input
15	B ENCODER		B signal - ENCODER input
16	B/ ENCODER		B/ signal - ENCODER input
17 18 19	SECONDARY output selection		Pin 18 connected to 17 = TTL/RS422 (factory jumper preconfiguration) Pin 18 connected to 19 = HTL
20	SHIELD		SECONDARY output cable shield connection
21 22 23	ENCODER power supply selection		Pin 22 connected to 21 = +5Vdc (factory jumper preconfiguration) Pin 22 connected to 23 = +24Vdc
24	SHIELD		Encoder cable shield connection

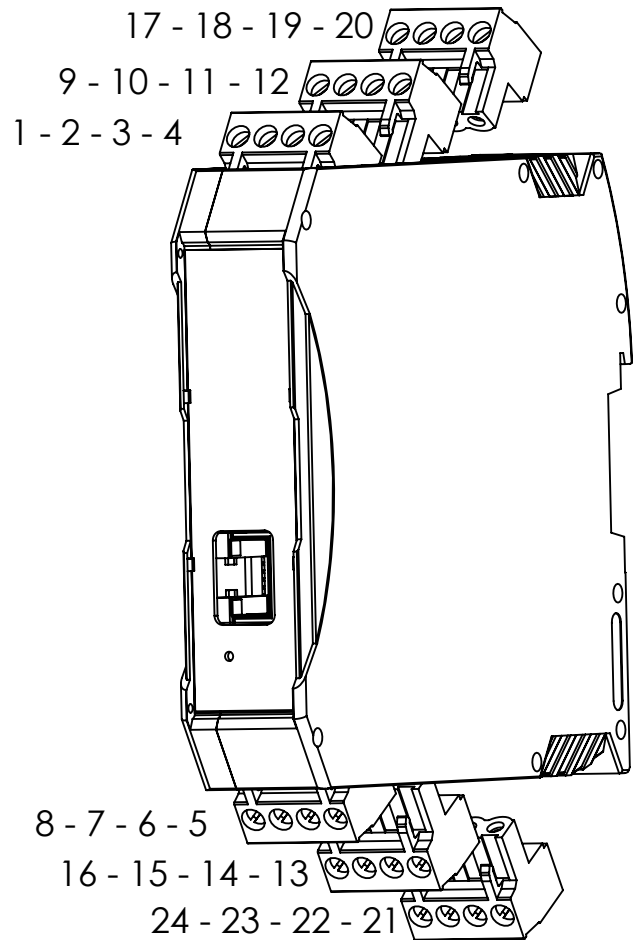

DIMENSIONS

Dimensions are in millimeters

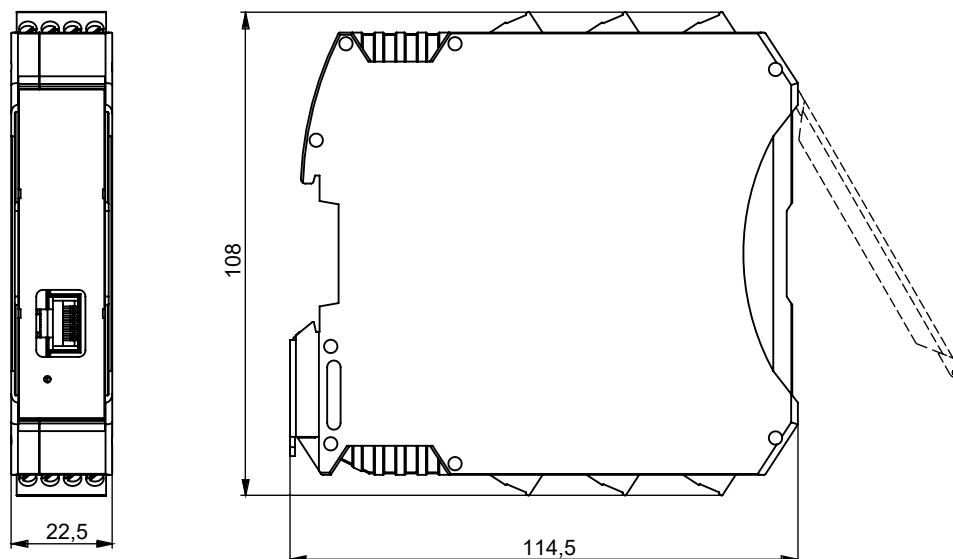



INSTALLATION

1. Clip the splitter on the DIN rail.
2. Check the power supply is switched off and make the terminal blocks electrical connections per wiring table printed on the product.
3. Check or configure the jumpers' positions.
4. Plug the RJ45 cord from the splitter to the safety motion controller.
5. Power on the devices.

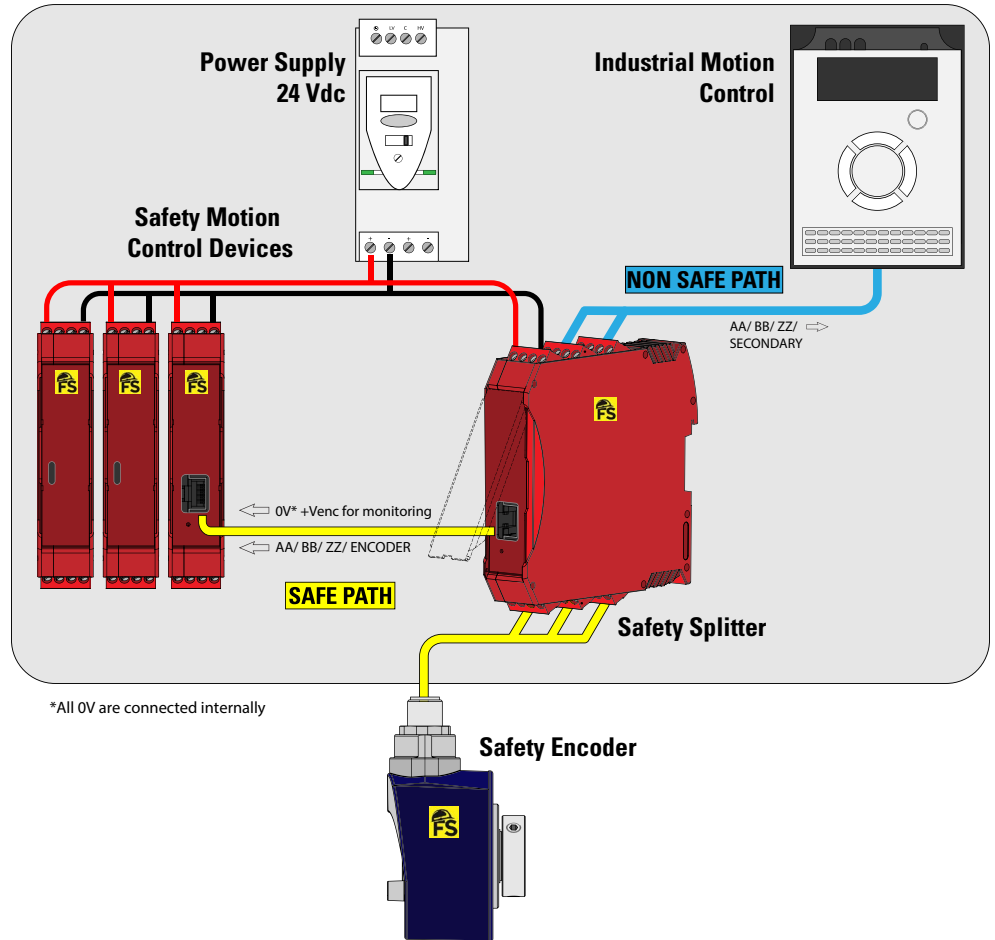

Splitters in association with RJ45 cables (see accessories section) are compatible with safety motion controllers from BEI Sensors partners:

- EAR-001 can be connected to NEG0003001 and NEG0003002. Safety module Interface sine/cosine and TTL respectively - consult factory
- EAR-002 can be connected to NEG0003003. Safety module interface HTL - consult factory
- Other safety motion controllers with adapted RJ45 cable assemblies



GENERAL NOTES

For a safe installation according to the required safety level needed in the application, refer to the user safety User Manual. The safety User Manual provides the technical information (drawings, electrical data, etc...) for a safe integration.



ORDERING OPTIONS

Example : EAR-001



001: Splitter for TTL/RS422 or sine 1Vpp encoder interface
002: Splitter for HTL encoder interface