

CP Series

Dual Low Pressure Sensor CPAP, BiPAP, APAP Applications

- Highly integrated dual sensors with ADC and DSP
- Combined Differential and Gage Sensors in one device
- 4 Differential Pressure Ranges per device (± 250 Pa to ± 2.5 k Pa)
- 4 Gage Pressure Ranges per device (± 2 k Pa to ± 6 k Pa)
- 16-bit resolution each channel range
- Ultra low noise, 17.5-bit Effective Resolution
- Selectable Bandwidth Filter from 25Hz to 250Hz
- Very High Accuracy $\pm 0.05\%$ of Selected Range
- Excellent Long Term Stability
- Output Update Rate up to 500Hz
- Temperature Compensated 5°C to 50°C
- Supply Voltage Compensation
- Standard I²C and SPI Interface
- Available in 3-port and 4-port configurations



Product Summary

Superior's CP Series sensor module for PAP applications employ *NimbleSense™*, a proprietary architecture achieving very high dynamic range to create the industry's best performing pressure sensing for CPAP, BiPAP and APAP devices. Incorporating both differential and gage pressure sensors in the same package, the CP Series supports four programmable pressure ranges for each embedded sensor. The differential pressure sensor can be user programmed from ± 250 to 2.5 k Pa (± 1 to 10 inH₂O) full scale ranges while the gage pressure sensor is programmable from ± 2 , to 6 k Pa (± 8 to 24 inH₂O) full scale ranges.

The CP Series provides a new level of sensor integration into the PAP market by combining two advanced piezoresistive sensing elements with integrated amplification, ADC, DSP and processor intelligence to greatly simplify integration efforts. The CP Series leverages floating point technology to provide a highly precise digital output. Advanced

digital processing enables new functionality thus simplifying system development, adding manufacturing ease and increasing reliability. Available in 3-port and 4-port configurations for maximum design flexibility, the CP Series optimizes performance, reliability and system cost for the challenging PAP market.

Industry leading accuracy – The CP Series measures dry air and non-aggressive gas pressure with very high accuracy typically within 0.05% of the selected range and Total Error Band that is typically within 0.15% FSS.

Constructed with a high reliability plastic enclosure, the CP201 provides the ideal combination of very high performance and reliability while ensuring customers have a high-volume, cost-effective solution optimized for a wide array of PAP devices.

Table of Contents

- 1 Maximum Ratings..... 2
- 2 Suggested Operating Conditions 2
- 3 Environmental 2
- 4 Equivalent Circuit..... 2
- 5 Feature List 3
- 6 Performance Characteristics 3
- 7 Electrical Characteristics..... 4
 - 7.1 Supply Characteristics..... 4
 - 7.2 Reset Characteristics 4
 - 7.3 DAV Characteristics 4
 - 7.4 SPI Characteristics 5
 - 7.5 I²C Characteristics 5
- 8 Materials..... 5
 - 8.1 Wetted Materials..... 5
 - 8.2 Material Compliance 6
- 9 System Overview 6
- 10 Interface 7
 - 10.1 Reset 7
 - 10.2 Communication Interface Selection 7
 - 10.3 SPI Interface..... 7
 - 10.4 I²C Interface 8
 - 10.4.1 I²C Address 8
 - 10.4.2 I²C Communications Model 8
 - 10.4.3 I²C Clock Stretching 9
 - 10.4.4 I²C Bus Compatibility..... 9
 - 10.5 Extended Data Acquisition 9
 - 10.5.1 Available Extended Data 9
 - 10.5.2 SPI Extended Data Read 9
 - 10.5.3 I²C Extended Data Read 10
 - 10.6 Control Registers 10
 - 10.6.1 Mode Control Register 10
 - 10.6.2 Rate Control Register 11
 - 10.7 Computing Pressure 11
- 11 Mechanical and Manufacturing..... 12
 - 11.1 Package Dimensions (CP201-SM04) 12
 - 11.2 Package Dimensions (CP301-SM06) 13
 - 11.3 Suggested Pad Layout (CP201/CP301) 13
 - 11.4 Pinout (CP201/CP301) 14
 - 11.5 Reflow Soldering and Handling Conditions 14
 - 11.6 Packaging Options 15
 - 11.6.1 Tray Packaging 15
 - 11.6.2 Tape and Reel 16
 - 11.7 Part Identification 16
- 12 Ordering Information 17
- 13 Packaging Labeling..... 17
- 14 Revisions..... 18
- 15 Warranty..... 18

1 Maximum Ratings

Parameter	Sym	Min	Max	Units
Supply Voltage	V _{DDM}	Gnd-0.3	4.0	V
Voltage on I/O Pins	V _{DD} > 3.3V	Gnd-0.3	5.8	V
	V _{DD} ≤ 3.3V	Gnd-0.3	V _{DD} +2.5	V
I/O Current	I _{IOM}	-25	25	mA

2 Suggested Operating Conditions

Parameter	Sym	Min	Max	Units
Supply Voltage	V _{DDOP}	2.8	3.5	V
Temperature	T _A	0	50	°C

3 Environmental

Parameter	Sym	Min	Max	Units	
Temperature Range	Compensated	T _{COMP}	5	50	°C
	Operating	T _{OP}	-20	85	°C
	Storage	T _{STG}	-40	85	°C
Humidity (Non-condensing)	RH _{OP}	0	95	% RH	
Vibration (10Hz-2kHz)	G _{VIBE}	-	15	g	
Shock (6 ms)	G _{SHOCK}	-	100	g	
Life	CY _{LIFE}	100M	-	Pressure Cycles	

4 Equivalent Circuit

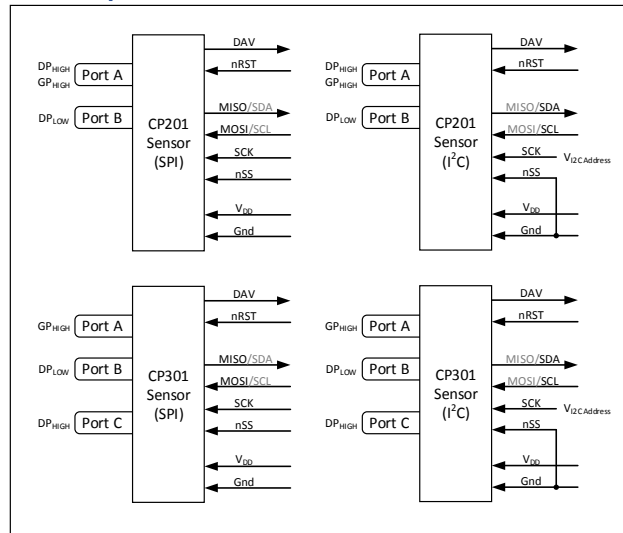

5 Feature List

Parameter	Sym	DP Sensor	GP Sensor	Units	Notes
Programmable FS Pressure Ranges	P _{NUM}	4		Each	
Programmable FS Range Extents	P _{EXT}	±250 to ±2.5k (±1.0 to ±10)	±2.0 to ±6.0k (±8.0 to ±24)	Pa (inH ₂ O)	4
Programmable BW Filter Corners	BW _{NUM}	4		Each	
BW Corner Frequency Extents	f _{BWEXT}	25 to 250		Hz	
Common Mode Pressure	P _{CM}	125	125	kPa	1
Proof Pressure	P _{PROOF}	10	250	kPa	2
Burst Pressure	P _{BURST}	30	750	kPa	3

- 1) Pressure applied to both ports simultaneously without incurring part damage.
- 2) Pressure at which the sensor will not suffer permanent damage.
- 3) Pressure if exceeded could cause permanent damage to the sensor.
- 4) Full scale units are in Pa. Units of inH₂O are approximate and for reference only.

6 Performance Characteristics

Note: Unless otherwise specified, characteristics specified with V_{DD} = 3.3V, T_A = 25C

Parameter	Sym	DP Sensor			GP Sensor			Units	Notes
		Min	Typ	Max	Min	Typ	Max		
Accuracy	P _{ACC}	-	0.05	0.1	-	0.05	0.1	% RNG	1
Total Error Band	TEB	-	0.1	0.3	-	0.15	0.5	% FSS	2
Long Term Stability	LTS _{YR1}	-	0.1	0.25	-	0.15	0.4	% FSS/YR1	6
Thermal Hysteresis	T _{HYS}	-	0.05	-	-	0.15	-	% FSS	
Pressure Hysteresis	P _{HYS}	-	0.05	-	-	0.05	-	% RNG	1
Position Sensitivity	P _{PS}	-	2.0	-	-	2.0	-	Pa	
Supply Rejection	P _{SR}	-	0.0005	-	-	0.005	-	Pa/mV	
Resolution	RES	-	16	-	-	16	-	bit	3
System ENOB	ENOB	-	15.7	-	-	15.7	-	Bit	4
Data Update Rate	f _{UPDATE}	485	498	512	485	498	512	Hz	5

- 1) Percentage of selected range.
- 2) Includes errors of offset, span and thermal effects.
- 3) Each of programmable range has the specified resolution.
- 4) ENOB stated for f_{BW} set to 25 Hz.
- 5) The internal update rate is fixed and does not change with range or filter settings. Sampling at lower data rates are possible provided the Nyquist frequency is observed. It is suggested to sample at least 2x the set f_{BW} frequency.
- 6) YR1 is the first year. The most significant drift occurs during the first year and is lessened for each subsequent year. For each subsequent year, use 25% of the prior years' drift figure to estimate the drift for that specific year.

7 Electrical Characteristics

7.1 Supply Characteristics

Parameter	Sym	CP201/CP301			Units	Notes
		Min	Typ	Max		
Supply Current	I_{DD}	-	6.5	7.0	mA	
Supply Capacitance	C_{DD}	-	10	-	uF	1

1) Supply capacitance is provided within the part however it is recommended to include a 0.1 uF decoupling cap near the supply pads.

7.2 Reset Characteristics

Parameter	Sym	Condition	CP201/CP301			Units	Notes
			Min	Typ	Max		
Power-On Reset Threshold	V_{PORR} V_{PORF}	Rising Voltage on V_{DD} Falling Voltage on V_{DD}	-	1.4	-	V	
			0.75	-	1.36	V	
Interface Detect Delay	t_{IOD}	From POR or External Reset	-	-	40	ms	
First Response Settling Time	t_{FRD}	From POR or External Reset	-	-	60	ms	1
External Reset Low	t_{RSTL}		15	-	-	us	
Input High Voltage	V_{IH}		$V_{DD}-0.6$	-	-		2
Input Low Voltage	V_{IL}		-	-	0.6		2
Internal Pull-Up Current	I_{PU}	$V_{IN} = 0V$	-	-10	-30	uA	2
Input Capacitance	C_{IN}		-	7	-	pF	2

1) The filter settling time to ensure the first reading is completely settled.

2) Input nRST

7.3 DAV Characteristics

Parameter	Sym	Condition	CP201/CP301			Units	Notes
			Min	Typ	Max		
Output High Voltage	V_{OH}	$I_O = -3 \text{ mA}$	$V_{DD}-0.7$	-	-	V	
Output Low Voltage	V_{OL}	$I_O = 8 \text{ mA}$	-	-	0.6	V	

7.4 SPI Characteristics

Parameter	Sym	Condition	CP201/CP301			Units	Notes
			Min	Typ	Max		
Output High Voltage	V_{OH}	$I_O = -3 \text{ mA}$	$V_{DD}-0.7$	-	-	V	1
Output Low Voltage	V_{OL}	$I_O = 8 \text{ mA}$	-	-	0.6	V	1
Input High Voltage	V_{IH}		$V_{DD}-0.6$	-	-		2, 3
Input Low Voltage	V_{IL}		-	-	0.6		2, 3
Internal Pull-Up Current	I_{PU}	$V_{IN} = 0V$	-	-10	-30	uA	2, 3
Time nSS to First SCK Edge	t_{SC}		100	-	-	us	
Clock Cycle Time	t_{CC}		8	-	-	us	
Byte to Byte Cycle Time	t_{BC}		100	-	-	us	
Time Last Clock to nSS High	t_{CN}		20	-	-	us	
Cycle Time nSS	t_{CS}		8	-	-	us	
Input Capacitance	C_{IN}		-	7	-	pF	2

- 1) Output MOSI
- 2) Inputs MISO, SCK, nSS
- 3) Inputs are 5V compliant.

7.5 I²C Characteristics

Parameter	Sym	Condition	CP201/CP301			Units	Notes
			Min	Typ	Max		
SCL Clock Frequency	f_{SCL}		100	-	400	kHz	
Clock Stretch Time	t_{CKSTR}		-	15	100	us	
Input High Voltage	V_{IH}		$V_{DD}-0.6$	-	-		
Input Low Voltage	V_{IL}		-	-	0.6		
Output Low Voltage	V_{OL}	$I_O = 8 \text{ mA}$	-	-	0.6	V	
Input Capacitance	C_{IO}		-	7	-	pF	

8 Materials

8.1 Wetted Materials

Parameter	Sym	CP201	CP301		Units	Notes
		DP _{HIGH} /DP _{LOW} /GP _{HIGH}	GP _{HIGH} /DP _{LOW}	DP _{HIGH}		
Wetted Materials	MAT _{WET}	Epoxy Nylon RTV Silicon Gold Aluminum	Epoxy Nylon RTV Silicon Gold Aluminum	Epoxy Nylon RTV Silicon		

8.2 Material Compliance

Parameter	Sym	CP201/CP301	Units	Notes
RoHS	REG _{RoHS}	RoHS Compliant		
REACH	REG _{REAC}	REACH Compliant		

9 System Overview

The CP Series pressure sensor is a fully integrated pressure acquisition system in a sensor module. The acquisition system includes anti-alias filters, data acquisition, sensor(s) compensation, bandwidth limiting and I/O functions. Refer to the figure below for the CP Series block diagram.

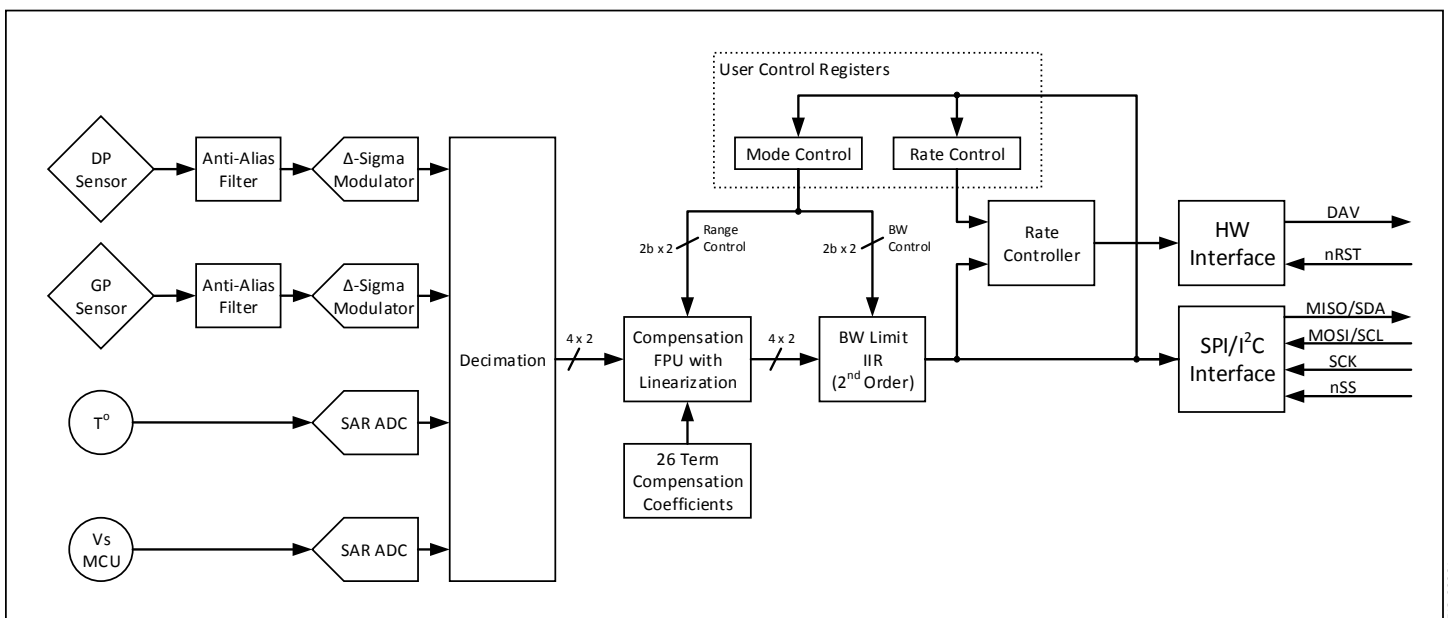

FIG-0096A

There are also two user controlled registers that tune the sensor to the specific user requirements. The first register is the Mode Control register that determines the output pressure range, the corner frequency of the bandwidth limiting filter.

The second register is the Rate Control register which controls the rate at which the Data Available (DAV) pin is asserted. The internal sensor data update rate is 498 Hz. The Rate Control register will throttle down the rate at which the Data Available pin (DAV) is asserted by counting down from the value set in the Rate Control Register and setting the DAV pin upon reaching zero in the down counter. The DAV is reset upon each read of the pressure sensor. An internal model of the Rate Controller is illustrated in the figure to the right. In the event the Rate Control Register is set to zero, the sensor will automatically select a Rate Control Register value that is determined by the currently selected bandwidth. Refer to Section 10.6.2 for details on the rate control register functionality.

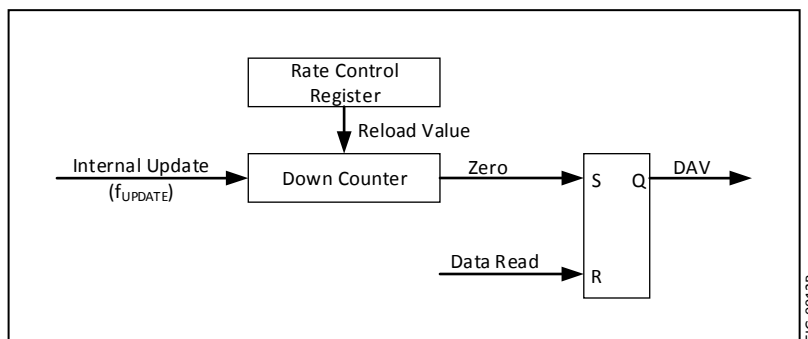

FIG-0012B

CP Series

Dual Low Pressure Sensor

10 Interface

10.1 Reset

Reset timing is shown in the diagram below.

The communications method (SPI or I²C) is established during the time just after rest. During this time (t_{IOD}), no communications should take place.

Also, the internal filters are settling during the time t_{FRD} and data acquired during this time may not be fully settled.

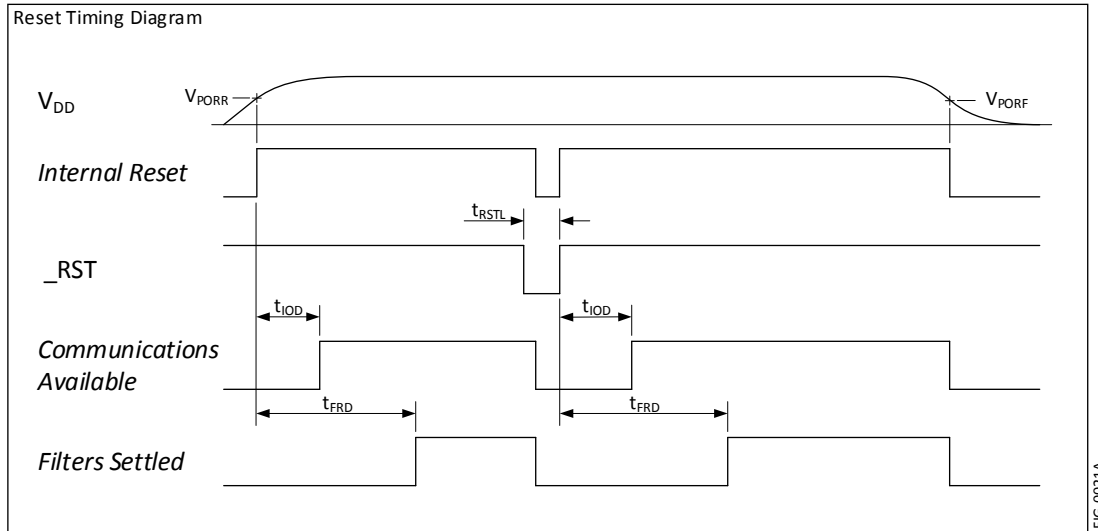

10.2 Communication Interface Selection

The communications interface is selected by interrogating the nSS pin after the internal power on reset delay. If nSS is high, the SPI interface will be selected otherwise (if low) the I²C interface will be selected. Grounding the nSS pin is an acceptable method for selecting the I²C interface.

10.3 SPI Interface

The SPI interface uses a minimum of 16-bit transfer for all communications. Data is MSB first for both MOSI and MISO data transfers. Refer to the figure below for specific timing requirements.

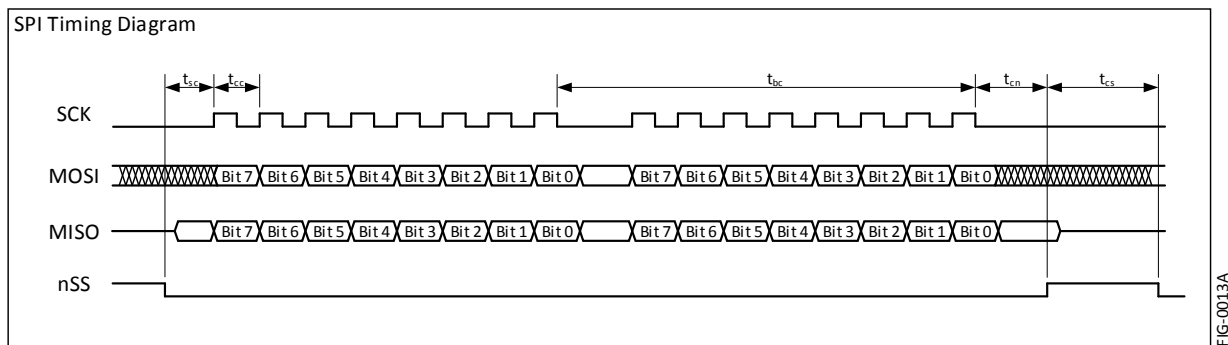

The data communications has been reduced to a simple 16 bit transfer model for reading the DP pressure output. The GP pressure sensor can be read via the extended data acquisition (Section 10.5). Each communication cycle consists of master sending the Mode and Rate data to be placed into the sensor Mode Register and Rate Registers respectively. Simultaneously, the sensor sends the pressure data for the master to receive. Refer to the figure below for the data communication model of the sensor.

The requirement to send the Mode and Rate bytes on each data read cycle is intentional. The purpose is to force the master to send specific data for each communication and prevent inadvertent data from being sent to the sensor. Since a SPI interface will generally re-circulate data through its shift register, the intention is to prevent the pressure output from the sensor from being re-circulated back to the sensor and potentially causing unintended corruption of manufacturing data. Note: The first two bytes out are the DP pressure sensor. To receive the data from the GP and extended data, continue to read bytes from the sensor (see Section 10.5). Data sent to the sensor (MOSI), after the first two bytes of the transaction, is ignored.

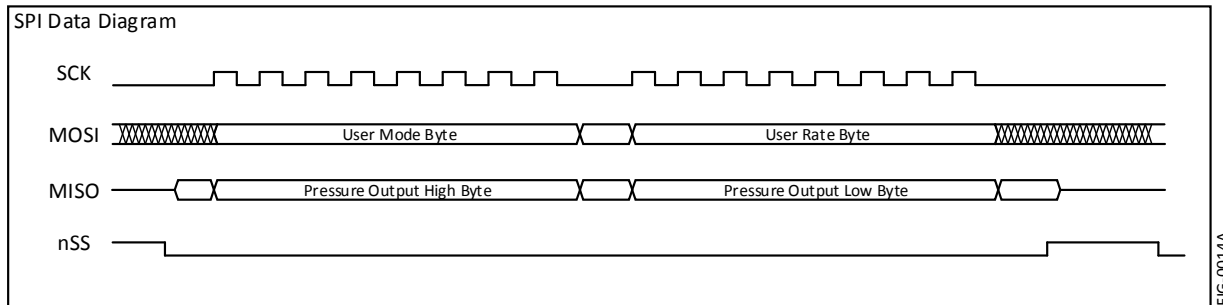

10.4 I²C Interface

The CP Series is compatible with the I²C protocol. For detailed information regarding the I²C protocol, please refer to the Philips I²C Bus Specification, Version 2.

10.4.1 I²C Address

I2C Address Selection Table			
R1 (kΩ)	R2 (kΩ)	Address (decimal)	Address (hex)
120	5.6	49	0x31
120	12	48	0x30
120	27	47	0x2F
120	51	46	0x2E
120	100	45	0x2D
56	100	44	0x2C
30	100	43	0x2B
15	100	42	0x2A
5.6	100	41	0x29
0	NoPop	40	0x28

The I²C address is set to 0x28 by grounding the SCK line. Other I²C addresses can be established by applying a voltage to the SCK line by use of a resistor divider across the sensor supply voltage. The suggested resistor values and the respective I²C address are shown in the table to the left.

Note: R1 is the lower resistor of the divider where R2 is the upper resistor of the divider.

10.4.2 I²C Communications Model

The sensor is configured as a slave device and as such, the communicating host must be configured as a master. There are two types of possible data transfers, data transfers from the master transmitter to an addressed sensor (WRITE), and data transfers from an addressed sensor to a master receiver (READ). The master device initiates both types of data transfers and provides the serial clock pulses on SCL.

The communications model for I²C is similar to that of SPI however, since I²C is a half-duplex protocol, the transfer of information to and from the sensor is separated into two separate communications. This is in contrast to the SPI interface where the transmitted and received data occurs simultaneously to and from the host. Refer to the figure to the right for the data communication model for the CP Series sensor.

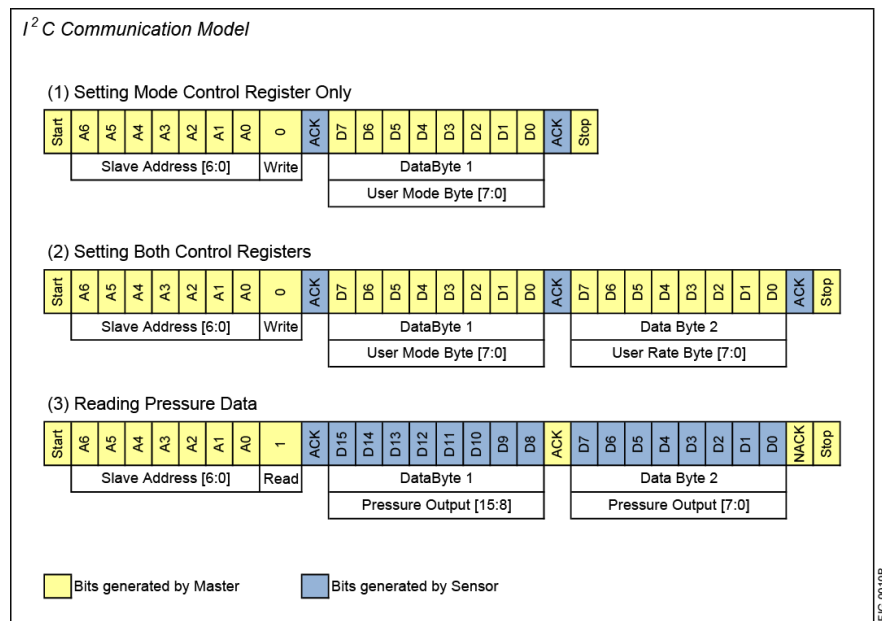

10.5.3 I²C Extended Data Read

Reading the extended data via the I²C interface is similar to using the SPI interface where the master can simply continue reading the sensor during the pressure reading transfer. The master continues Ack'ing until the number of desired bytes are read.

10.6 Control Registers

10.6.1 Mode Control Register

Default Value: 0xBB

Details of the Mode Control register are illustrated in the figure to the right.

Bits 0-1 control the DP output pressure range.

Bits 2-3 control the DP BW Limit Filter.

Bits 4-5 control the GP output pressure range.

Bits 6-7 control the GP BW Limit Filter.

It should also be noted that upon changing the Mode Control value, there is a one cycle latency before the new Mode Control value becomes valid. That is, the data of the communication cycle following a change to the Mode Control register will not reflect the change. It is not until the second communication cycle that the change in the Mode Control register will be reflected in the output data.

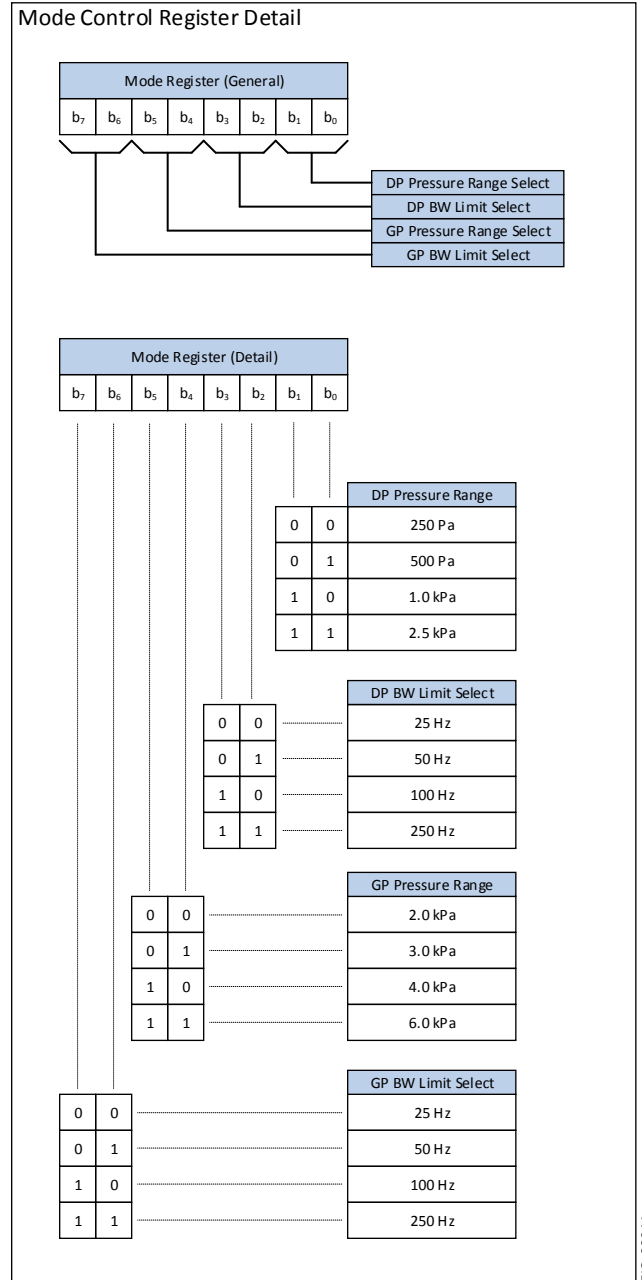

CP Series

Dual Low Pressure Sensor

10.6.2 Rate Control Register

Default Value: 0x00

The Rate Control Register controls the rate at which the DAV pin is asserted indicating new data is available. This register is primarily used to throttle down the actual data transfer rate (when using the DAV as the trigger to sample data).

The function of this register is that it is the reload value of a data rate down-counter. The value of the Rate Control Register is the divisor of the 498 Hz internal data rate. Since a divisor of zero is not possible, a zero value will select the auto-select rate mode. In this mode, the rate is selected based on the selected DP bandwidth limit. The auto rate value is roughly two times the corner frequency of the currently selected bandwidth limit in all auto selected rates.

Note: Start-up time for the sensor is approximately 60ms for the first sample to be settled. Requesting data during this time will result in invalid information. However, this start-up time can be used for configuring the Mode and Rate registers by performing a transfer with the desired Mode and Rate register values and discarding the received pressure data. After waiting the required start-up time, the sensor will respond with desired data since the Mode and Rate registers have been pre-established.

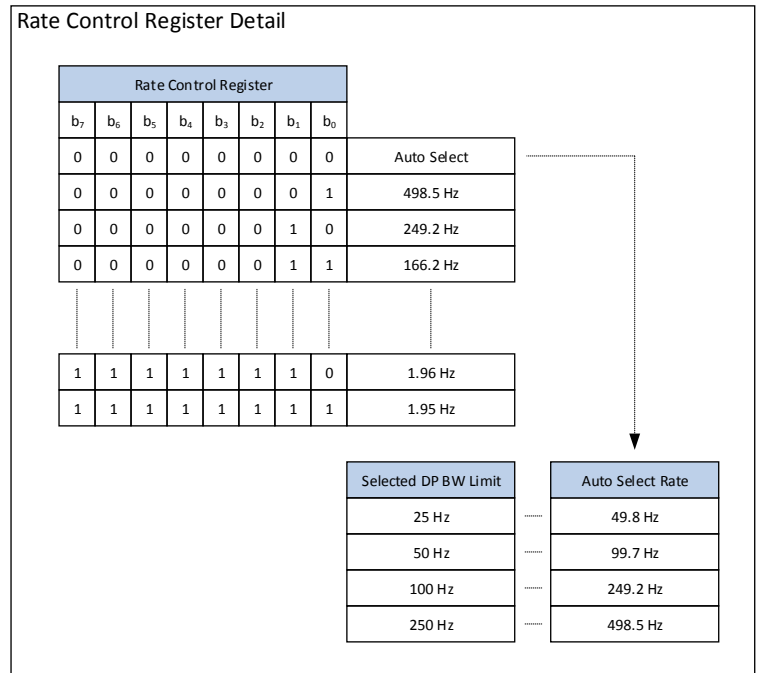

FIG-0097A

10.7 Computing Pressure

The pressure data is in the form of 16-bit signed integer sent in high byte then low byte order. This is a differential output by definition and the data range is $\pm 2^{15}$. There is a 10% margin in the output scaling and the selected full scale will reside in the 90% band of the total available output data range. Refer to Equation 1 (below) for the general model for computing the output pressure. As an example, if the sensor output is 3,647 counts and the selected pressure range is 500 Pa, then the output pressure is 61.832 Pa. Conversely, for a -3,647 count with the selected pressure range of 500 Pa, the computed output pressure is -61.832 Pa. Refer to Example 1 (below) for the specific example computation.

$$Eq\ 1: P_{Pa} = \frac{Out_{DIGITAL}}{90\% * 2^{15}} * Range_{SELECTED}$$

$$Example\ 1: P_{Pa} = \frac{3,647}{90\% * 2^{15}} * 500\ Pa = 61.832\ Pa$$

11 Mechanical and Manufacturing

11.1 Package Dimensions (CP201-SM04)

SM04 Package Dimensions

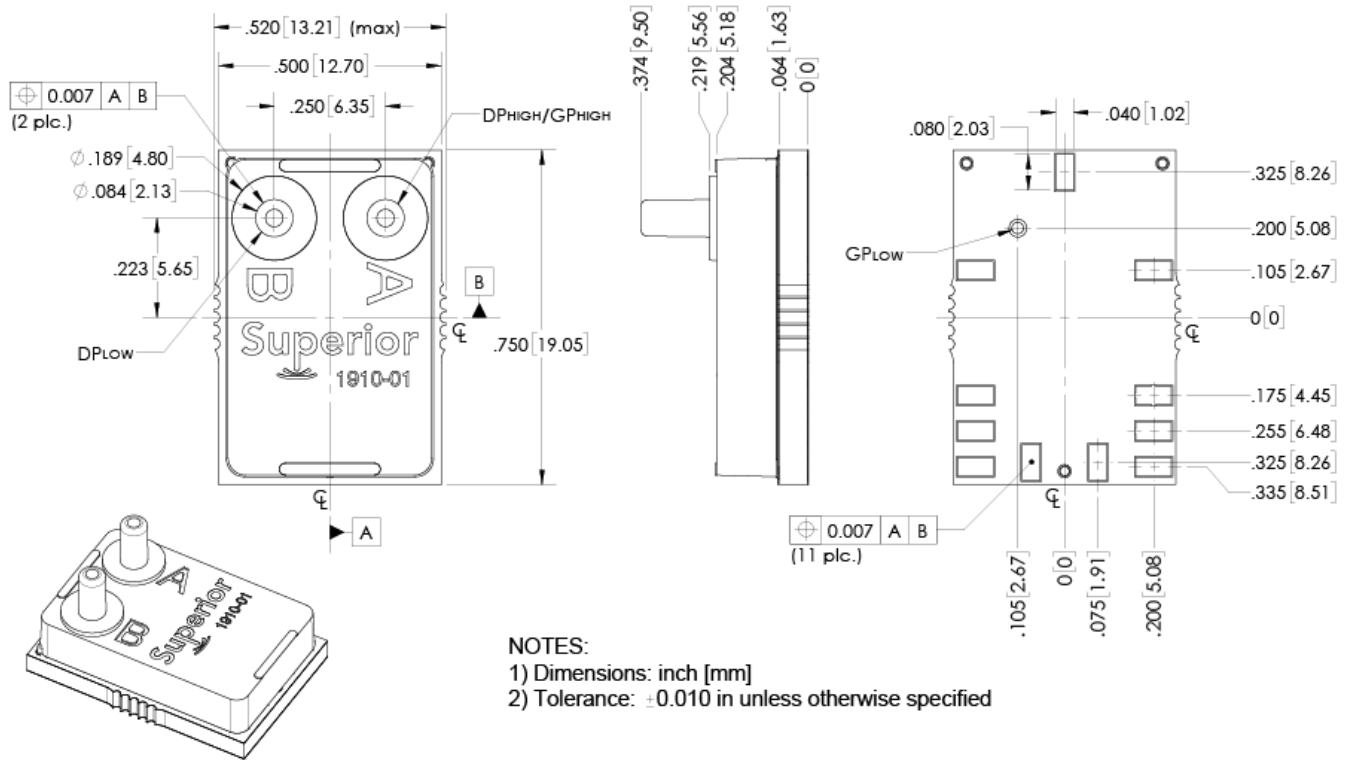
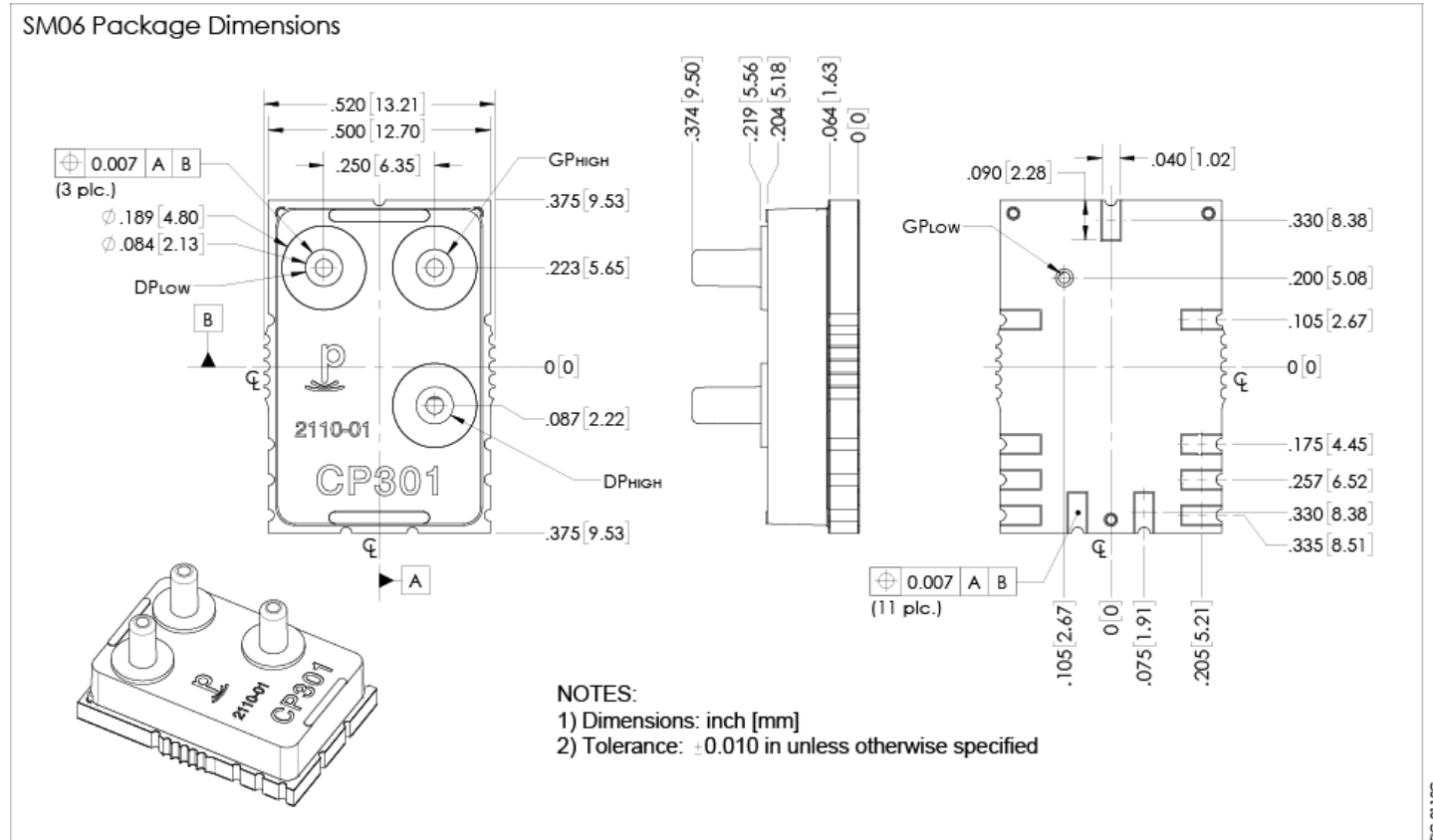

FIG-0110C

CP Series

Dual Low Pressure Sensor

11.2 Package Dimensions (CP301-SM06)



11.3 Suggested Pad Layout (CP201/CP301)

The suggested pad layout is shown in the figure below. An Eagle PCB symbol library is available with the shown pad dimensions. Please consult the factory to obtain the library.

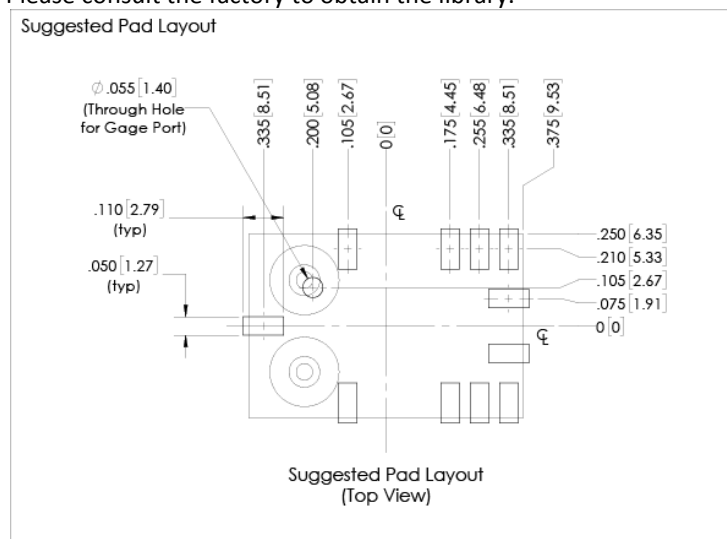

11.4 Pinout (CP201/CP301)

Pin	Sym	SPI	I ² C
1	nSS	Slave Select (active low)	Tie to Ground
2	MOSI/SCL	MOSI	SCL
3	MISO/SDA	MISO	SDA
4	SCK	Serial Clock	See Section 10.4.1
5	DNC	Do Not Connect	
6	DNC	Do Not Connect	
7	DNC	Do Not Connect	
8	Gnd	Ground	
9	V _{DD}	Sensor Supply	
10	nRST	Reset (active low)	
11	DAV	Data Available	

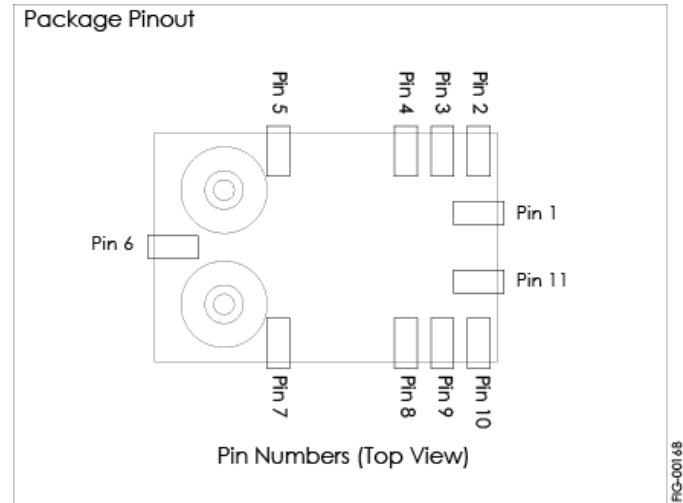

11.5 Reflow Soldering and Handling Conditions

Parameter	Sym	Val	Units
Soldering Specifications (Max)			
Preheat Ramp Rate	t _{PHRR}	3	°C/s
Soak Time	t _{SOAK}	3	min
Time Above 217C	t _{GT217}	50	s
Time Above 230C	t _{GT230}	40	s
Time Above 250C	t _{GT250}	15	s
Peak Temperature	t _{PT}	255	°C
Cooling Ramp Rate	t _{CRR}	-4	°C/s
Weight	W _{PRT}	3.5	gm
Moisture Sensitivity	MSL	3	
ESD (Human Body Model)	ESD	2	kV

11.6 Packaging Options

11.6.1 Tray Packaging

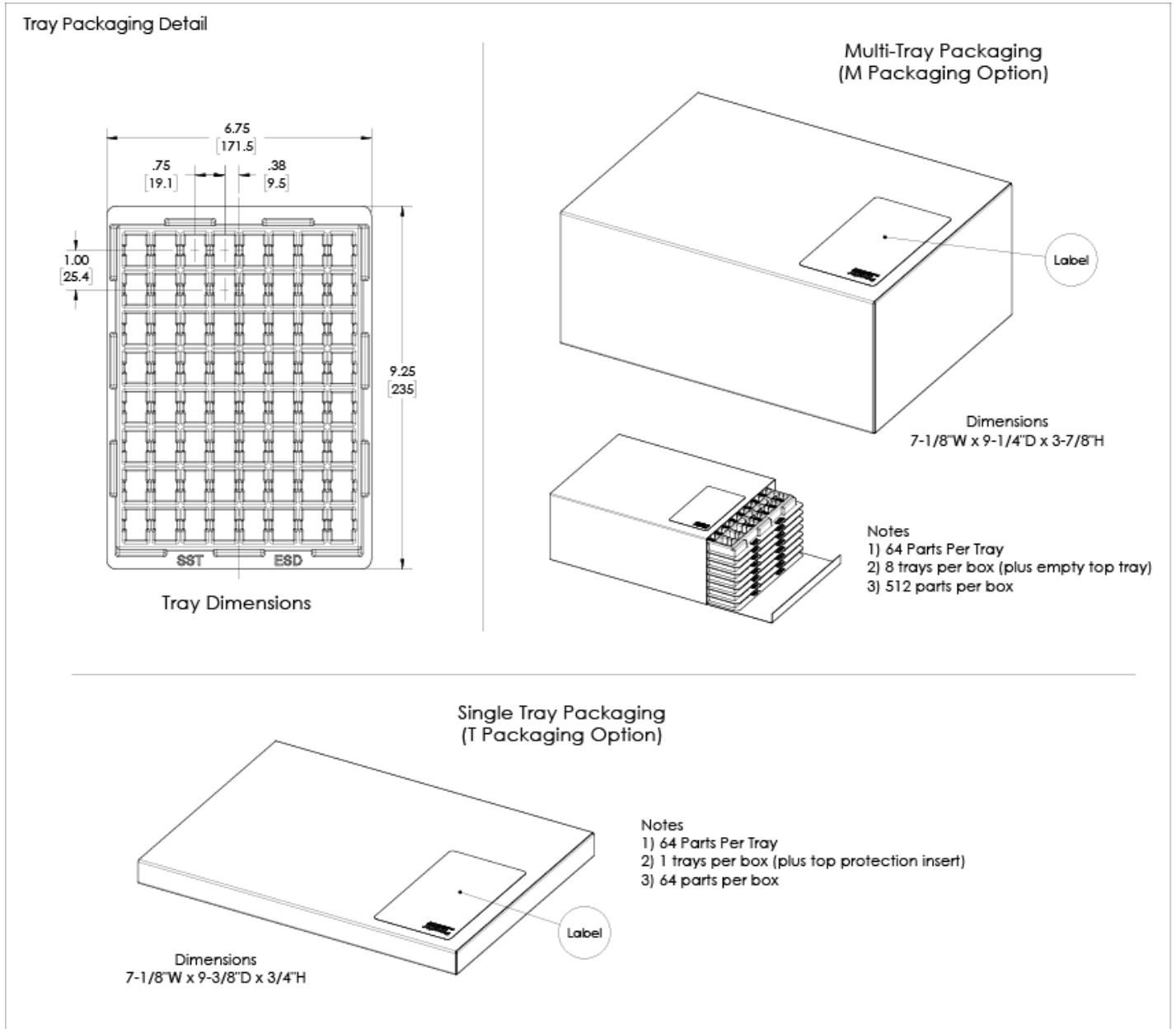

11.6.2 Tape and Reel

Tape and Reel Detail

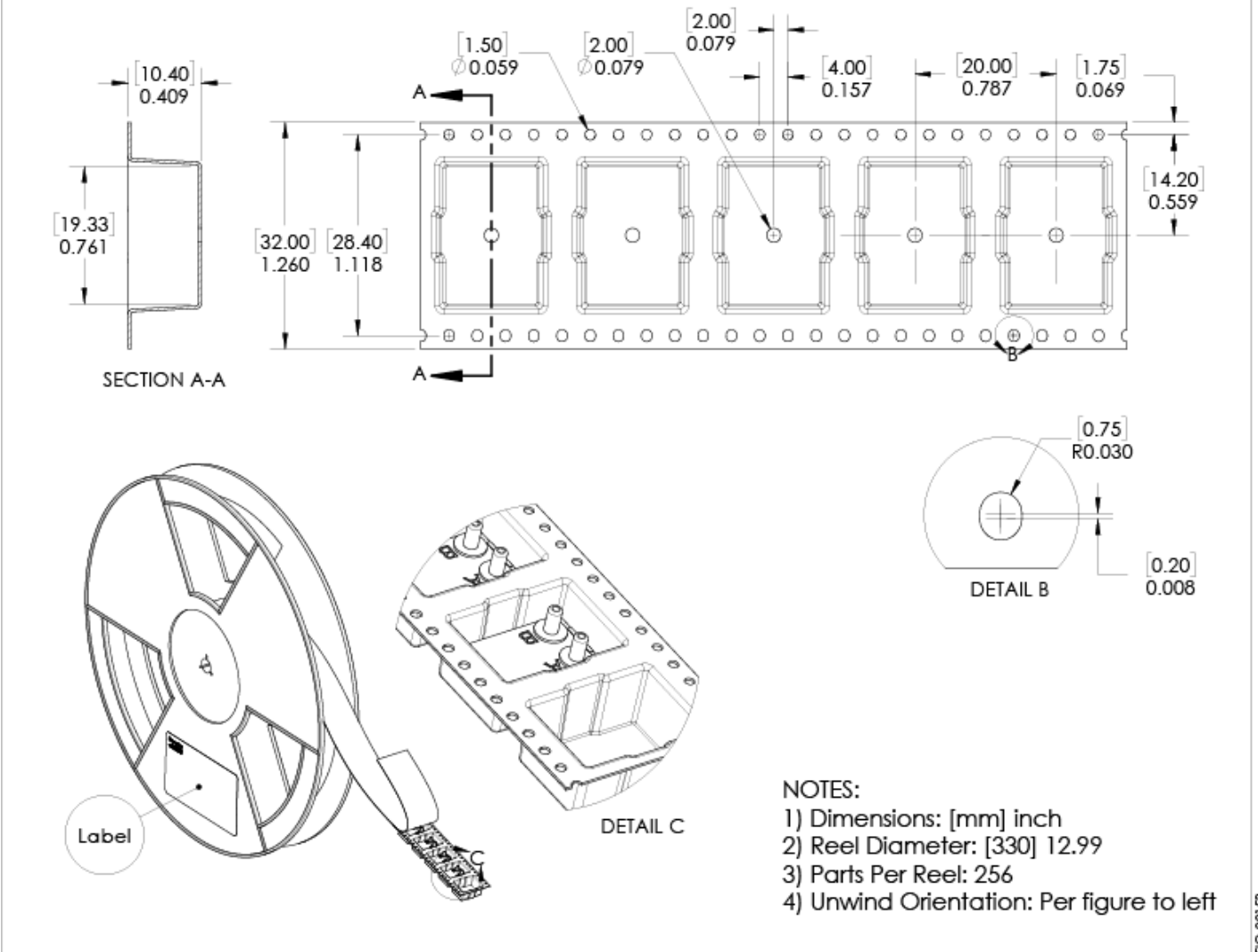

11.7 Part Identification

Part Marking

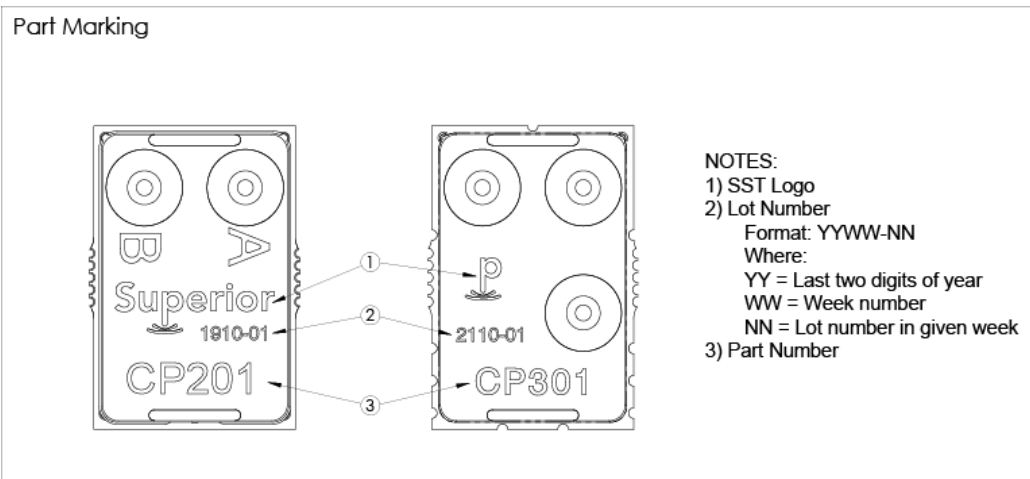

12 Ordering Information

Part Number	Part Package	Packaging	Packaging Qty	Order Number
CP201-SM04	SM04	Tape and Reel	256	CP201-SM04-R
		Multi-Tray	512	CP201-SM04-M
		Single Tray	64	CP201-SM04-T
		Quarter Reel	64	CP201-SM04-Q
		Cut Tape	1-63	CP201-SM04-C
CP301-SM06	SM06	Tape and Reel	256	CP201-SM06-R
		Multi-Tray	512	CP201-SM06-M
		Single Tray	64	CP201-SM06-T
		Quarter Reel	64	CP201-SM06-Q
		Cut Tape	1-63	CP201-SM06-C

13 Packaging Labeling

Packaging labels are provided with barcode Code 128 symbology. The provided fields are Company Name, Part Number, Packaging ID, Quantity and Country of Origin. The Packaging ID traces back to the Lot Number (or Lot Numbers) contained in the package. The purpose is to eliminate multiple labels (one for each included Lot Number) in the event of multiple Lot Numbers within a single package. This is for ease of customer tracking and maintenance. The Packaging ID is a 24-bit value printed in hexadecimal format.



FIG-0046