



21mm Size Ring Type EC21A/EC21C Series

Part number	EC21A1520407		
Actuator length	15mm		
Detent torque	16±7mN·m		
Number of detent	30		
Number of pulse	15		
Operating temperature range	-40°C to +85°C		
Electrical performance	Ratings	10mA 5V DC	
	Output signal	Two phase A and B	
	Max./min. operating current(Resistive load)	10mA/1mA	
	Insulation resistance	100MΩ min. 250V DC	
	Voltage proof	300V AC for 1 minute or 360V AC for 2s	
Mechanical performance	Actuator strength	Pushing direction	100N
		Pulling direction	100N
Durability	Operating life	50,000 cycles	

Minimum order unit (pcs.)

Japan

600

Export

1,200

Photo

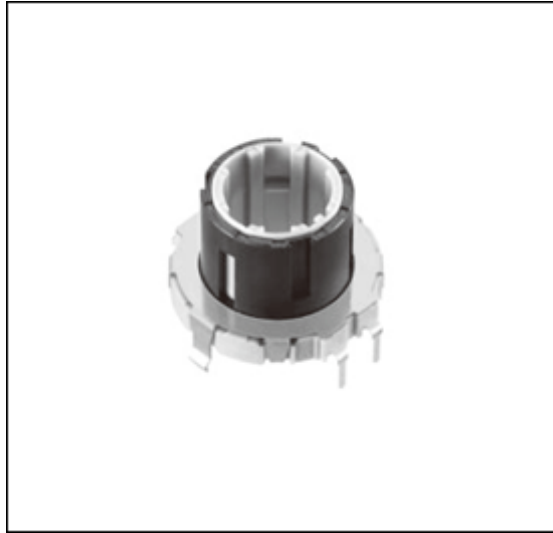

Dimensions

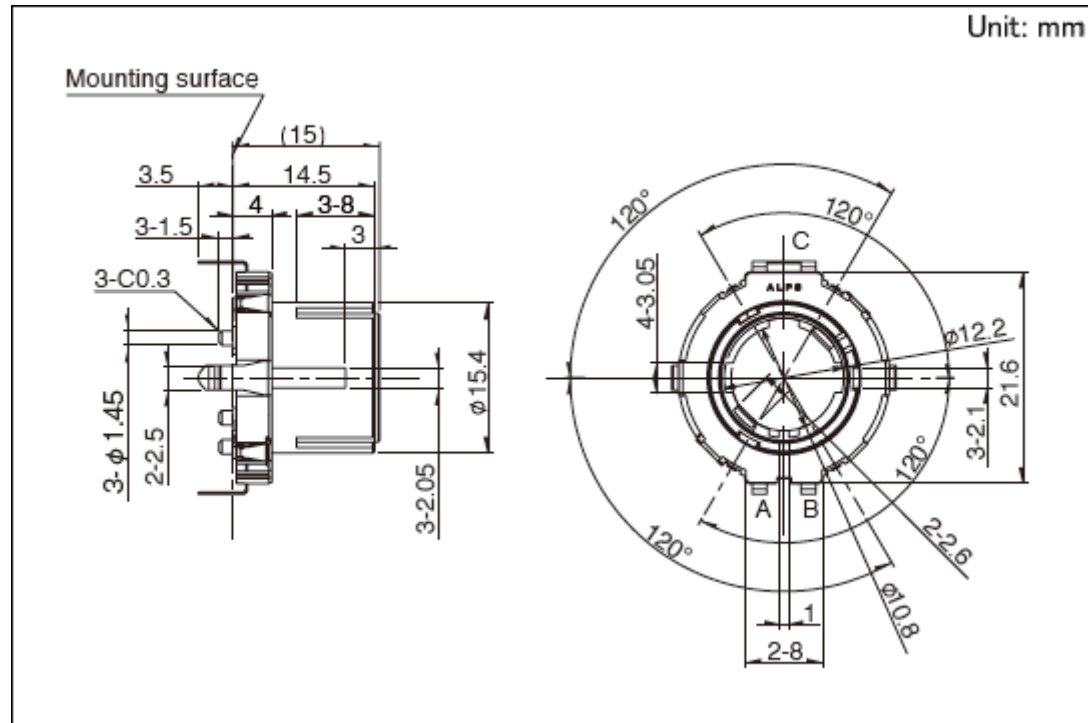

Mounting Hole Dimensions

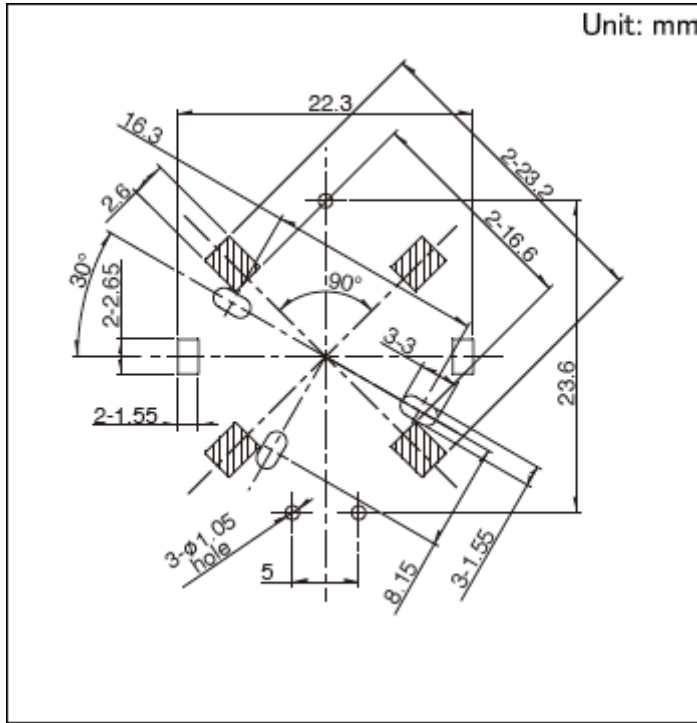

Do not wire the shaded area

Output Wave

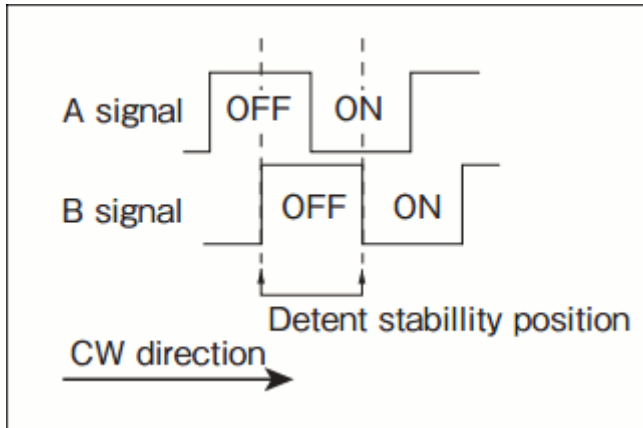

Sliding Noise

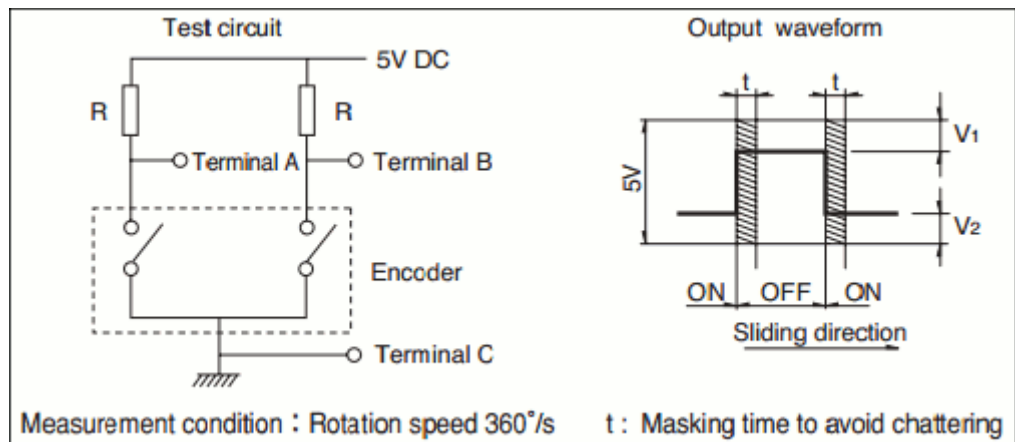

V1=V2=2.5V max.

At R = 5kΩ Chattering : 5ms max. Bounce : 5ms max.

Packing Specifications

Tray

Number of packages (pcs.)	1 case / Japan	600
	1 case / export packing	1,200
Export package measurements (mm)	360×540×290	

Soldering Conditions

Reference for Dip Soldering

Preheating	Soldering surfacetemperature	100°C max.
	Heating time	2 min. max.
Dip soldering	Soldering temperature	260±5°C
	Soldering time	5±1s