

ECSW SERIES

Current Sensors

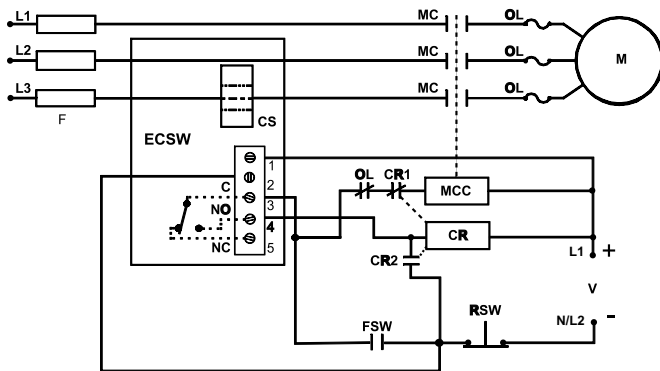

Wiring Diagram



MC = Motor Contactor
M = Motor
F = Fuses
OL = Overload

RSW = Reset Switch
FSW = Fan or Float Contacts
CR = Control Relay
CS = Current Sensor
MCC = Motor Contactor Coil

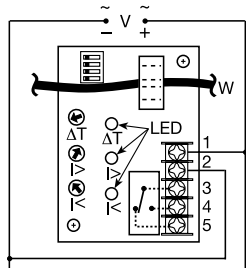

V = Voltage
I> = Adjustable Overcurrent
I< = Adjustable Undercurrent
W = Monitored Wire
ΔT - Adjustable Trip Delay

Description

The ECSW Series of single-phase, AC window, current sensors includes adjustable overcurrent and undercurrent trip points. Detects locked rotor, jam, loss of load, an open heater or lamp load, a broken belt, or loss of suction. LED's aid in trip point adjustment and provide fault indication. The built-in toroidal sensor eliminates the need for an external current transformer. The output can be electrically latched after a fault, or automatically reset. Remote resetting of a latched output by removing input voltage. The unit includes switch selectable zero current detection, latched, normally de-energized or energized output operation. Time delays are included to improve operation and eliminate nuisance tripping.

Features & Benefits

FEATURES	BENEFITS
Built-in toroidal current sensing	Eliminates need to install stand alone current transformer and provides isolation from monitored circuit
Encapsulated	Protects against shock, vibration, and humidity
LED indication	Visual indication for trip point adjustment and fault indication
Multiple switch selectable features	User selectable zero current detection, latched, normally de-energized, or energized output adds application flexibility
Adjustable trip delay	Eliminates nuisance tripping and prevents rapid cycling
Isolated 10A, SPDT output contacts	Allows control of loads for AC or DC voltages

Operation

When the input voltage is applied, sensing delay on startup begins and the output transfers (if normally energized is selected). Upon completion of the startup delay, sensing of the monitored current begins. As long as current is above undercurrent trip point and below the overcurrent trip point (inside the window), the output relay remains in its normal operating condition and both red LED's are OFF. The green LED glows when the output is energized. If current varies outside the window, the associated red LED glows, and the trip delay begins. If the current remains outside the window for the full

Ordering Information

MODEL	INPUT VOLTAGE	TRIP POINT ADJUST.	TRIP DELAY	SENSING DELAY ON STARTUP	CONNECT.
ECSW3LABT	24VDC	0.5 - 5A	0.150 - 7s	0.1s	Terminal blocks
ECSW4HBHT	120VAC	5 - 50A	0.5 - 50s	6s	Terminal blocks
ECSW4LADT	120VAC	0.5 - 5A	0.150 - 7s	2s	Terminal blocks
ECSW4LBHT	120VAC	0.5 - 5A	0.5 - 50s	6s	Terminal blocks
ECSW4MACT	120VAC	2 - 20A	0.150 - 7s	1s	Terminal blocks
ECSW4MBHT	120VAC	2 - 20A	0.5 - 50s	6s	Terminal blocks
ECSW4MBGT	120VAC	2 - 20A	0.5 - 50s	5s	Terminal blocks
ECSW6MBHT	230VAC	2 - 20A	0.5 - 50s	6s	Terminal blocks

If you don't find the part you need, call us for a custom product 800-843-8848

ECSW SERIES

trip delay, the relay transfers to fault condition state. If the current returns to normal levels (inside the window) during the trip delay, the red LED goes OFF, the trip delay is reset, and the output remains in the normal condition.

Reset: Remove input voltage or open latch switch. If zero current detection is selected, the unit will reset as soon as zero current is detected.

Operation With Zero Current Detection Enabled: If the current decreases to zero within the trip delay period, then zero current is viewed as an acceptable current level. The unit's output remains in its normal operating state. This allows the monitored load to cycle ON and OFF without nuisance tripping the ECSW. Zero current is defined as current flow of less than 250 milliamp-turns.

Note: When zero current detect is selected, the latching operation of switch SW2 is canceled; the output will not latch after a fault trip.

Notes on Operation

1. There is no hysteresis on the trip points. The overcurrent and undercurrent trip points should be adjusted to provide adequate protection against short cycling.
2. If the upper setpoint is set below the lower setpoint, both red LED's will glow indicating a setting error.
3. If zero current detection is selected (SW2 ON), and the system is wired to disconnect the monitored load, the system may short cycle. After the unit trips, the load de-energizes, and zero current is detected. The ECSW resets, and the load energizes again immediately and may be short cycled.
4. The sensing delay on start up only occurs when input voltage is applied. When zero current detection is selected, the trip delay must be longer than the duration of the inrush current or the unit will trip on the inrush current.

Typical Pump or Fan Protection Circuit Operation

Window Current Sensing: With the ECSW connected as shown in the diagram, a load may be monitored and controlled for over and undercurrent. The ECSW Series' on board CT (CS) may be placed on the line or load side of the contactor. The ECSW selection switches are set for zero current sensing (see Selector Switch SW2) and the output selection is normally de-energized (see Selector Switch SW3). The input voltage (V) is applied to the ECSW continually. As the control switch (FSW) is closed, the input voltage (V) is applied to the motor contactor coil (MCC), and the motor (M) energizes. As long as the current remains below the overcurrent and above the undercurrent trip points, the ECSW's output contacts remain de-energized. If the load current should rise above or fall below a trip point,

for the full trip delay, the normally open (NO) contact will close, energizing the control relay (CR) coil. The CR normally closed contact (CR1) opens and the MCC de-energizes and CR latches on through its normally open contacts (CR2). Reset is accomplished by momentarily opening the normally closed reset switch (RSW).

Note: If the current falls to zero within the trip delay, the ECSW remains de-energized. The sensing delay on startup occurs when input voltage is applied therefore trip delay must be longer than the duration of the motor's inrush current. The external latching relay CR2 is required in this system to prevent rapid cycling. A timer can be added to provide an automatic reset.

Selector Switch

ON ↔ OFF

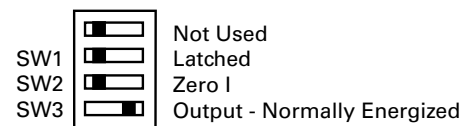

Mode Selection Switches

- SW1 = Latched or Auto reset selector**
OFF - Automatic reset after a fault
ON - Output relay latches after a fault trips the unit
- SW2 = Zero current detection (below 250 mA)**
OFF - Zero current detection disabled
ON - Zero current detection enabled
- SW3 = Output during normal operation**
OFF - Output relay de-energized
ON - Output relay energized