

ED-29768-000
SHT 1.1

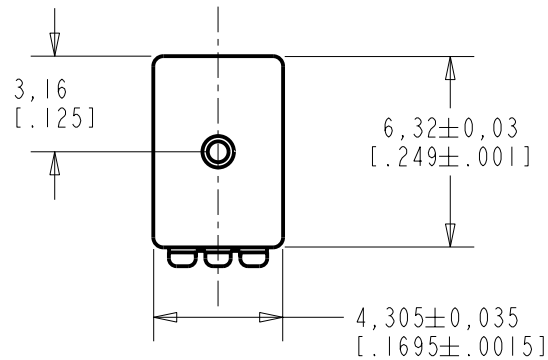

NOTE:

- 1 A POSITIVE GOING VOLTAGE AT TERMINAL 2, RELATIVE TO THE CENTER TAP TERMINAL, OR A NEGATIVE GOING VOLTAGE AT TERMINAL 1, RELATIVE TO THE CENTER TAP TERMINAL, CAUSES A DECREASE IN PRESSURE AT THE SOUND OUTLET.
- 2 LOCATED FROM TWO SURFACES FOR CUSTOMER CONVENIENCE. ONLY APPLICABLE FROM ONE SURFACE, NOT TO BE USED TOGETHER. HORIZONTAL LOCATION FOR TERMINAL CENTERED TO ±0,17 [0.007].

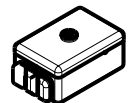
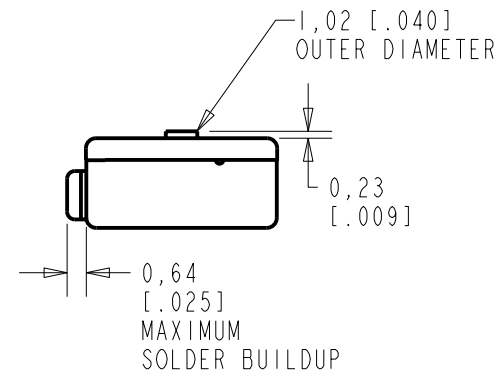
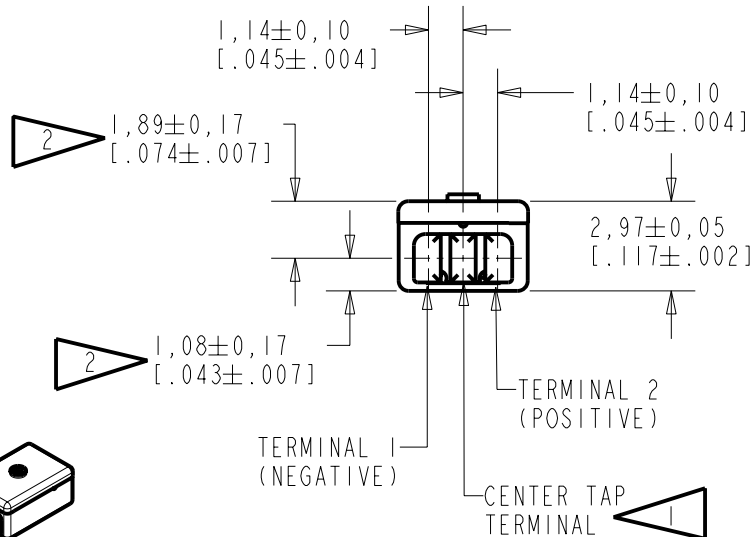

SCALE 2:1

NOMINAL WEIGHT
.31 GRAM

DIMENSIONS IN MILLIMETERS [INCHES]

KNOWLES ELECTRONICS
ITASCA, ILLINOIS U.S.A.

Revision	C.O. #	Implementation Date	RELEASE LEVEL	REVISION
			Released	A
A	CI0103510	12-28-05		
SCALE: 4:1				
TITLE: RECEIVER			DR. BY DATE	
OUTLINE DRAWING			CRG 12-28-05	
ED-29768-000			CK. BY DATE	
SHT 1.1			GJP 1-2-06	
			APP. BY DATE	
			GJP 1-2-06	

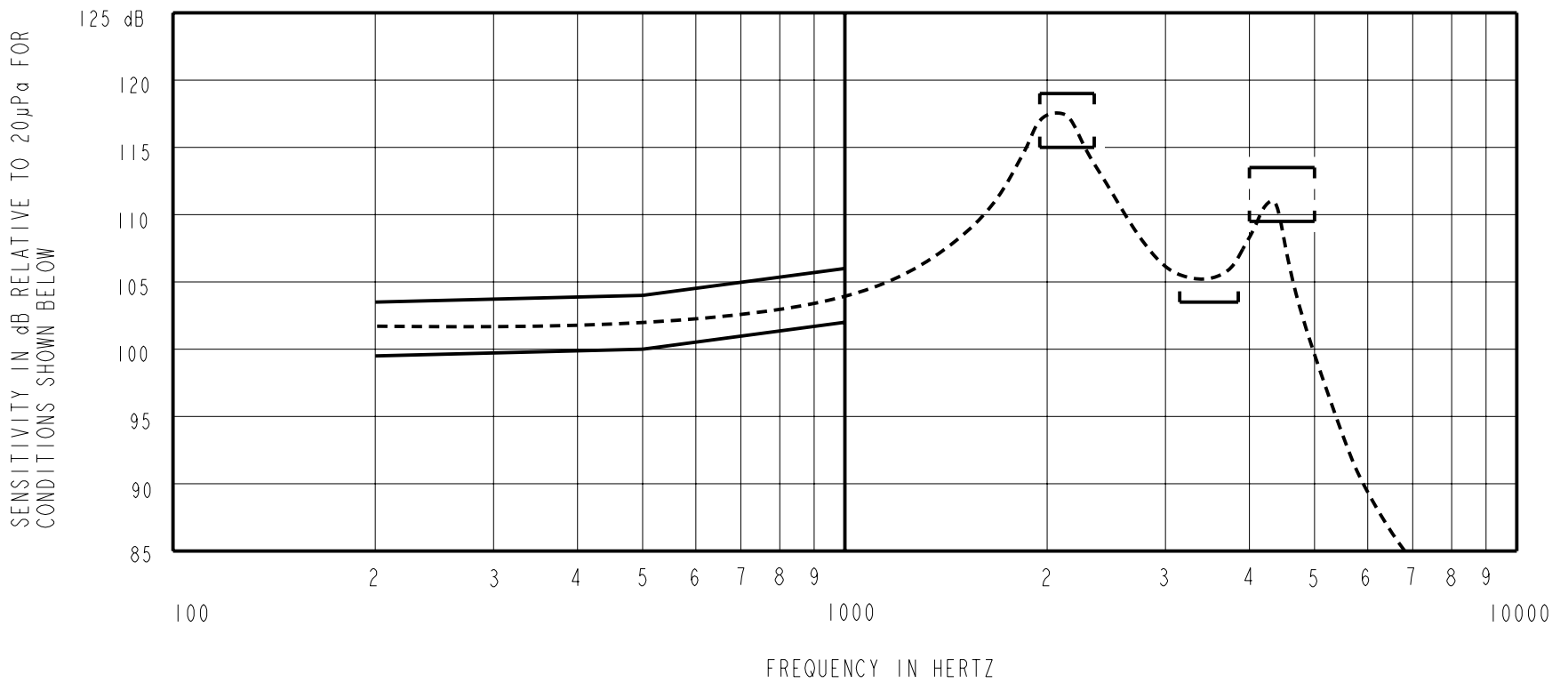

NOTES:

1. MEASUREMENTS MADE USING 10m (.394") X 1mm (.039") ID TUBE CONNECTED TO A SIMULATED ANSI S3.7-1973 TYPE HA-3 COUPLER. (IEC 126).

2. SENSITIVITY

FREQUENCY	MIN.	MAX.
200	99.5	103.5
500	100.0	104.0
1000	102.0	106.0
1950-2350	115.0	119.0
3150-3850	103.5	---
4000-5000	109.5	113.5

3. RESPONSE, IMPEDANCE, AND DISTORTION MEASUREMENTS MADE USING THE ELECTRICAL TEST CONDITIONS SHOWN BELOW.
4. ELECTRICAL SOURCE IMPEDANCE MUST BE GREATER THAN 20 TIMES 1KHz IMPEDANCE FOR TEST CONDITIONS SHOWN BELOW.
5. INDIVIDUAL SPECIFICATIONS.

PORT LOCATION	IMPEDANCE OHMS ±15%		DCR @20°C OHMS ±10%	DISTORTION		ELECTRICAL TEST CONDITIONS	
	1KHz	500Hz		MAX. %	FREQ Hz	AC mA RMS	DC mA
0JM	1450	780	376	5	800	0.50	0.00

Revision	C.O. #	Implementation Date	RELEASE LEVEL	REVISION
			Released	A
A	C10103510	12-28-05		
WHEN TEST LIMITS ARE USED TO ESTABLISH INCOMING INSPECTION ACCEPTANCE/REJECTION CRITERIA, CORRELATION OF TEST EQUIPMENT WITH KNOWLES IS ALSO REQUIRED FOR ELIMINATION OF EQUIPMENT AND TEST METHOD VARIATION			DR. BY	DATE
TITLE: RECEIVER PERFORMANCE SPECIFICATION			ED-29768-000	GJP
			SHT 2.1	1-2-06
			APP. BY	DATE
			GJP	1-2-06

KNOWLES ELECTRONICS
ITASCA, ILLINOIS U.S.A.