

Type EDS, 85 °C Long Life Electric Double Layer Supercapacitor



Type EDS, 85 °C electric double layer supercapacitors offer high capacitance values in a thru hole stacked coin type package. Primarily designed for integrated circuit voltage backup, the capacitors can also be used to deliver the initial power from batteries.

Highlights

- Long life
- High discharge current
- 85 °C Operating temperature

Specifications

Operating Temperature Range	-25 °C to +85 °C
Rated Voltage Range	3.6 Vdc to 5.5 Vdc
Capacitance Range	0.047 F to 1.5 F
Life, Moisture and Temperature Characteristics	After the following procedures have been performed, measure the capacitance and ESR at +20 °C.
Life Test:	Apply the max. operating voltage for 1000 h at +85 °C
Capacitance Change	±30% of the initial measured value
ESR	≤ 4 times the initial specified value
Shelf Life:	Subject the capacitor to 1000 hours without voltage at +85 °C.
Capacitance Change	±30% of the initial measured value
ESR	≤ 4 times the initial specified value
Moisture Resistance:	Subject the capacitor to 240 hours at +40 °C at 90 to 95% RH without voltage.
Capacitance Change	±10% of the initial measured value
ESR	meets the initial specified value
Temperature Cycling	Stabilize the capacitor at each of the following temperatures for 1 hour in sequence, and then measure the capacitance and ESR at that temperature.
	1. +20 °C 2. -25 °C 3. +20 °C 4. +85 °C 5. +20 °C
Capacitance Change (at -25 °C)	±30% of the initial measured value
ESR (at -25 °C)	≤ 5 times the initial measured value
Capacitance Change (at +85 °C)	±30% of the initial measured value
ESR (at +85 °C)	≤ 4 times the initial measured value
Capacitance Change (Step 5 at +20 °C)	±10% of the initial measured value
ESR (Step 5 at +20 °C)	meets the initial specified value
RoHS Compliant without Exemptions	

Type EDS, 85 °C Long Life Electric Double Layer Supercapacitor

3.6 VDC					
CDE Part Number	Cap F	ESR 1 kHz Ω	Case Code		
			V Type	H Type	C Type
EDS473Z3R6*	0.047	120	V1	H1	C1
EDS104Z3R6*	0.1	75	V1	H1	C1
EDS224Z3R6*	0.22	75	V1	H1	C1
EDS334Z3R6*	0.33	75	V1	H1	C1
EDS474Z3R6*	0.47	50	V1	H1	C1
EDS105Z3R6*	1	30	V2	H2	C2
EDS155Z3R6*	1.5	30	V2	H2	C2

*V, H, or C

5.5 VDC			
CDE Part Number	Cap F	ESR 1 kHz Ω	Case Code
EDS104Z5R5C	0.1	120	C3
EDS224Z5R5C	0.22	75	C3
EDS334Z5R5C	0.33	75	C3
EDS474Z5R5C	0.47	50	C4
EDS684Z5R5C	0.68	50	C4
EDS105Z5R5C	1	30	C4

Part Numbering System

EDS

Series

224

Capacitance

224 = 0.22 F
473 = 0.047 F
105 = 1.0 F

Z

Tolerance

-20/+80%

5R5

Voltage

5R5 = 5.5 Vdc

C

Case Style

C = Radial
H = Horizontal Style
V = Vertical Style

EDS Outline Drawing

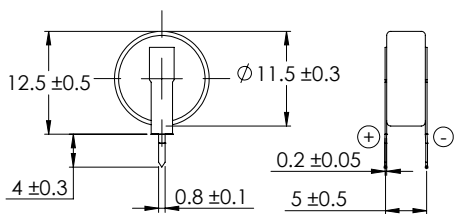

V1

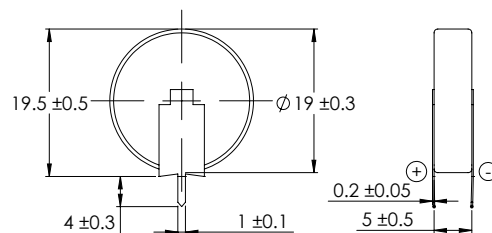

V2

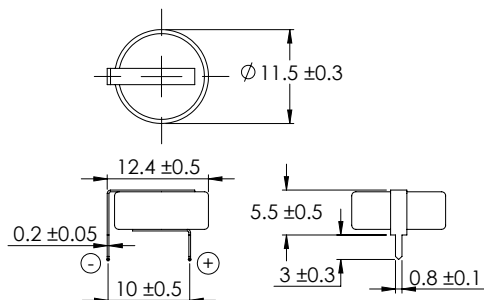

H1

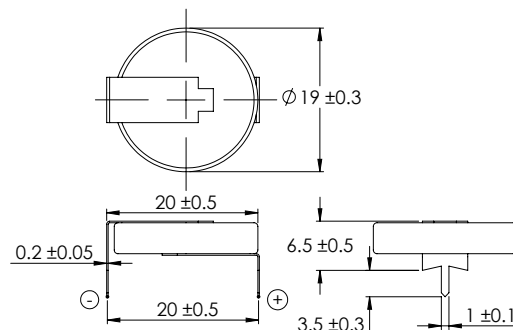

H2

Type EDS, 85 °C Long Life Electric Double Layer Supercapacitor

EDS Outline Drawing

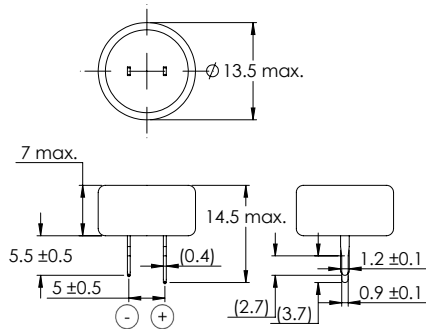

C1

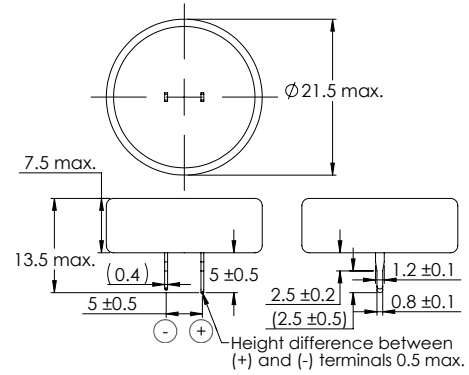

C2

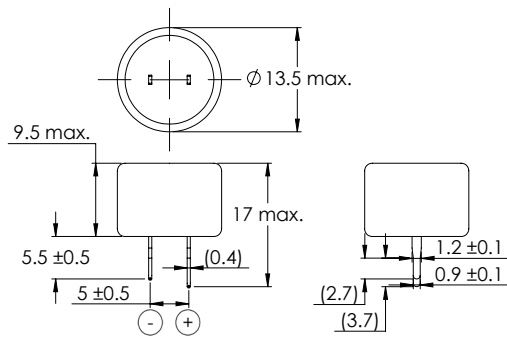

C3

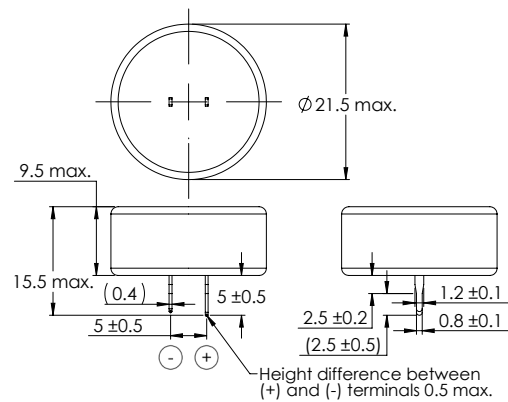

C4

Recommended Soldering Procedures

Hand Soldering	Use a 30W iron with a max. temperature of 350 °C for 3 seconds.
Wave Soldering	Pre-heat circuit board to a surface temp of 110 °C for a max. of 60 seconds, with a max. component temperature of 100 °C. Min. printed circuit board thickness of 0.8 mm. Recommended solder bath temperature of 240 °C with a max. dipping time of 5 seconds.