

# Type EDS, 85 °C Long Life Electric Double Layer Supercapacitor



Type EDS, 85 °C electric double layer supercapacitors offer high capacitance values in a thru hole stacked coin type package. Primarily designed for integrated circuit voltage backup, the capacitors can also be used to deliver the initial power from batteries.

## Highlights

- Long life
- High discharge current
- 85 °C Operating temperature

## Specifications

<b>Operating Temperature Range</b>	-25 °C to +85 °C
<b>Rated Voltage Range</b>	3.6 Vdc to 5.5 Vdc
<b>Capacitance Range</b>	0.047 F to 1.5 F
<b>Life, Moisture and Temperature Characteristics</b>	After the following procedures have been performed, measure the capacitance and ESR at +20 °C.
<b>Life Test:</b>	Apply the max. operating voltage for 1000 h at +85 °C
<b>Capacitance Change</b>	±30% of the initial measured value
<b>ESR</b>	≤ 4 times the initial specified value
<b>Shelf Life:</b>	Subject the capacitor to 1000 hours without voltage at +85 °C.
<b>Capacitance Change</b>	±30% of the initial measured value
<b>ESR</b>	≤ 4 times the initial specified value
<b>Moisture Resistance:</b>	Subject the capacitor to 240 hours at +40 °C at 90 to 95% RH without voltage.
<b>Capacitance Change</b>	±10% of the initial measured value
<b>ESR</b>	meets the initial specified value
<b>Temperature Cycling</b>	Stabilize the capacitor at each of the following temperatures for 1 hour in sequence, and then measure the capacitance and ESR at that temperature.
	1. +20 °C 2. -25 °C 3. +20 °C 4. +85 °C 5. +20 °C
<b>Capacitance Change (at -25 °C)</b>	±30% of the initial measured value
<b>ESR (at -25 °C)</b>	≤ 5 times the initial measured value
<b>Capacitance Change (at +85 °C)</b>	±30% of the initial measured value
<b>ESR (at +85 °C)</b>	≤ 4 times the initial measured value
<b>Capacitance Change (Step 5 at +20 °C)</b>	±10% of the initial measured value
<b>ESR (Step 5 at +20 °C)</b>	meets the initial specified value
<b>RoHS Compliant without Exemptions</b>	

# Type EDS, 85 °C Long Life Electric Double Layer Supercapacitor

3.6 VDC					
CDE Part Number	Cap F	ESR 1 kHz $\Omega$	Case Code		
			V Type	H Type	C Type
EDS473Z3R6*	0.047	120	V1	H1	C1
EDS104Z3R6*	0.1	75	V1	H1	C1
EDS224Z3R6*	0.22	75	V1	H1	C1
EDS334Z3R6*	0.33	75	V1	H1	C1
EDS474Z3R6*	0.47	50	V1	H1	C1
EDS105Z3R6*	1	30	V2	H2	C2
EDS155Z3R6*	1.5	30	V2	H2	C2

\*V, H, or C

5.5 VDC			
CDE Part Number	Cap F	ESR 1 kHz $\Omega$	Case Code
EDS104Z5R5C	0.1	120	C3
EDS224Z5R5C	0.22	75	C3
EDS334Z5R5C	0.33	75	C3
EDS474Z5R5C	0.47	50	C4
EDS684Z5R5C	0.68	50	C4
EDS105Z5R5C	1	30	C4

## Part Numbering System

**EDS**

Series

**224**

Capacitance

224 = 0.22 F  
473 = 0.047 F  
105 = 1.0 F

**Z**

Tolerance

-20/+80%

**5R5**

Voltage

5R5 = 5.5 Vdc

**C**

Case Style

C = Radial  
H = Horizontal Style  
V = Vertical Style

## EDS Outline Drawing

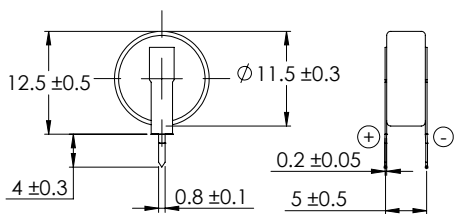

V1

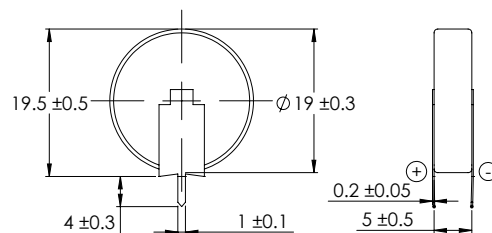

V2

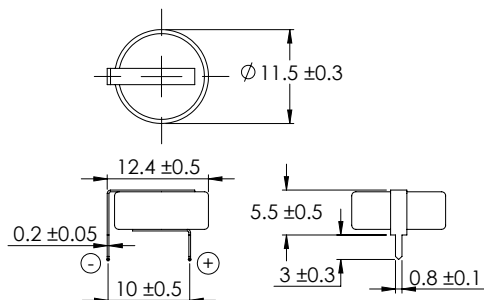

H1

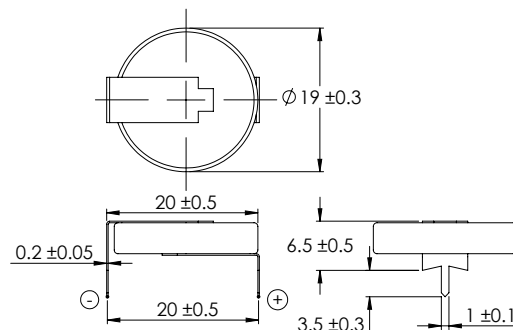

H2

