

Accessories

EFCT SERIES CURRENT TRANSFORMER



Current Sensor



Description

The EFCT series is a sensitive nickel-core current transformer used with Littelfuse relays to detect low levels of earth-leakage current.

Accessories



EFCT-1FC Flux Conditioner

used with the EFCT-1 to reduce saturation and prevent false operation due to large surge currents.

Ordering Information

ORDERING NUMBER	WINDOW SIZE, ID	WEIGHT
EFCT-26	26 mm (1.0")	0.4 kg (1 lb)
EFCT-1	82 mm (3.2")	0.9 kg (2 lb)
EFCT-2	139 mm (5.5")	2.7 kg (6 lb)

Specifications

Turns Ratio	100:1
Current Rating	5:0.05 A
Accuracy	3% @ 0.01 VA
Frequency	50 to 400 Hz ¹ 0 to 6 kHz for EL731
Insulation Level	600 V
Operating Temperature	-55 to 60°C (-67 to 140°F)
Application	EL731, FPU-32, FPS, MPU-32, MPS, SE-330, SE-701, SE-703
Certification	CSA, UL, CE
Compliance	RoHS, IEC 60044-1

Note: ¹ Frequency response may be extended for specific product families.

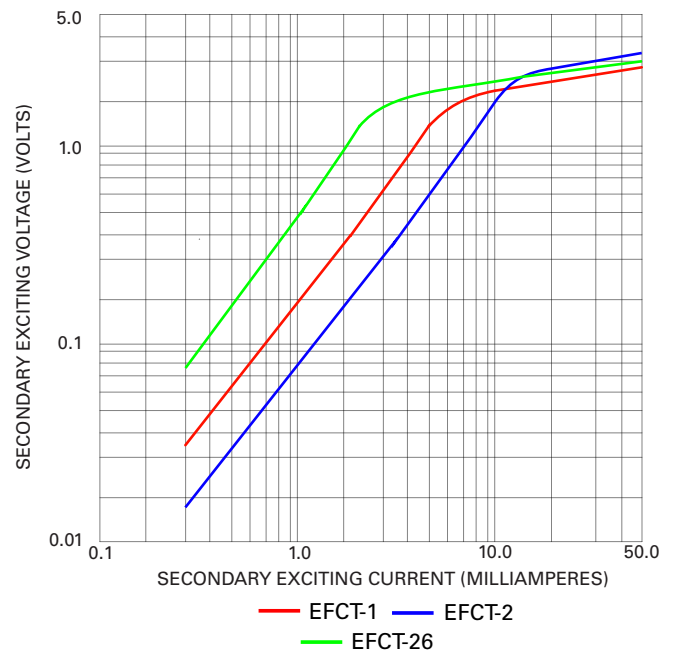

Accessories

EFCT SERIES CURRENT TRANSFORMER

Dimensions and Mounting Diagram

EFCT-1

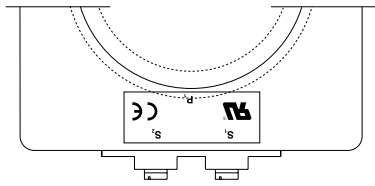

NOTES:

1. DIMENSIONS IN MILLIMETRES (INCHES).
2. MOUNTING SCREWS: M4 OR 8-32.
3. PRESS MOUNTING FEET IN PLACE USING INSTALLATION TOOL PROVIDED.
4. RoHS COMPLIANT.
5. EN 60044-1 COMPLIANT.

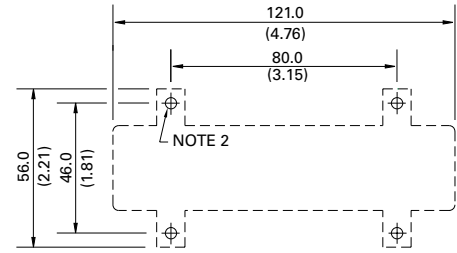

MOUNTING DETAIL

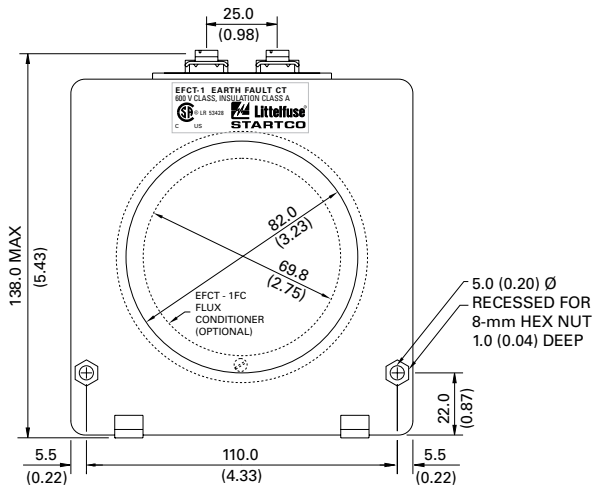

FRONT

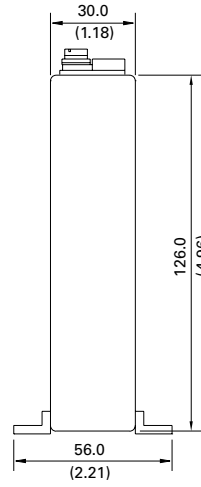

SIDE

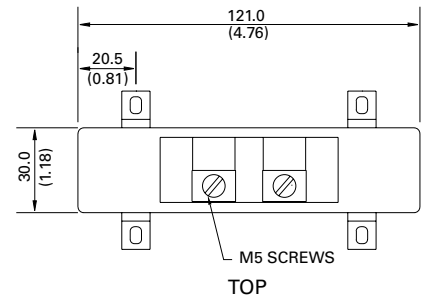

TOP

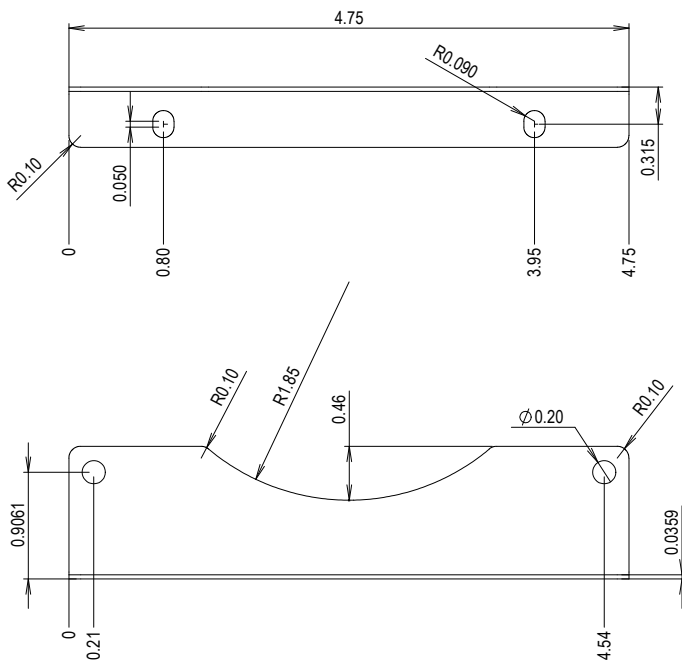

MOUNTING FEET

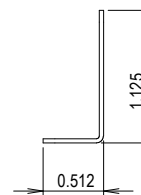
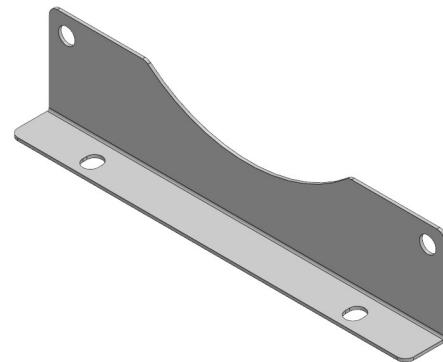

Dimensions and Mounting Diagram
EFCT-2

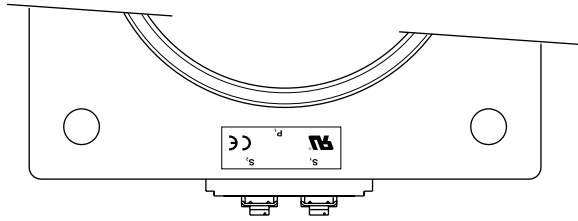

NOTES:

1. DIMENSIONS IN MILLIMETRES (INCHES).
2. MOUNTING SCREWS: M5 OR 10-32.
3. RoHS COMPLIANT.
4. EN 60044-1 COMPLIANT.

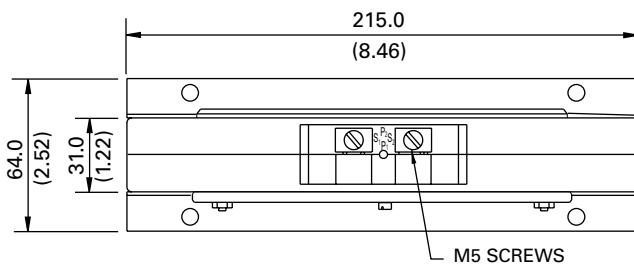

TOP

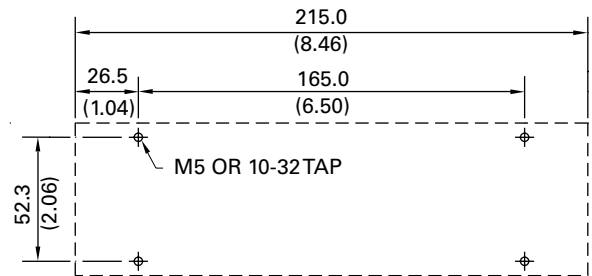

MOUNTING DETAIL

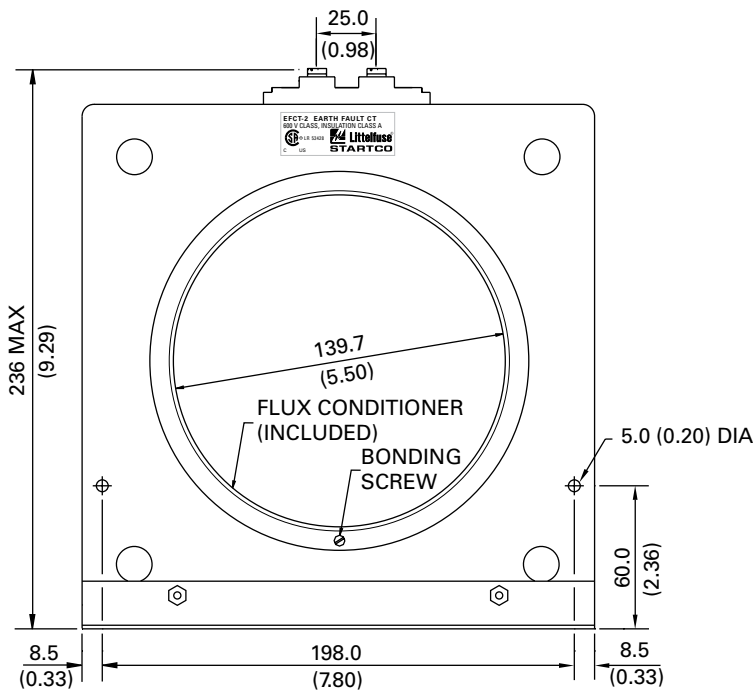

FRONT

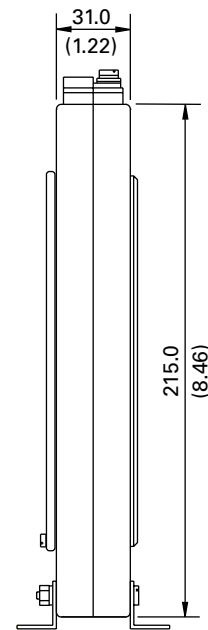

SIDE