

**SURFACE MOUNT GLASS PASSIVATED
SUPER FAST SILICON RECTIFIER
VOLTAGE RANGE 50 to 600 Volts CURRENT 1.0 Ampere**

FEATURES

- * Glass passivated device
- * Ideal for surface mounted applications
- * Low leakage current
- * Metallurgically bonded construction
- * P/N suffix V means AEC-Q101 qualified
- * P/N suffix V means Halogen-free

MECHANICAL DATA

- * Epoxy : Device has UL flammability classification 94V-0
- * Mounting position: Any
- * Weight: 0.057 gram

MAXIMUM RATINGS AND ELECTRICAL CHARACTERISTICS

Ratings at 25 °C ambient temperature unless otherwise specified.
Resistive or inductive load.

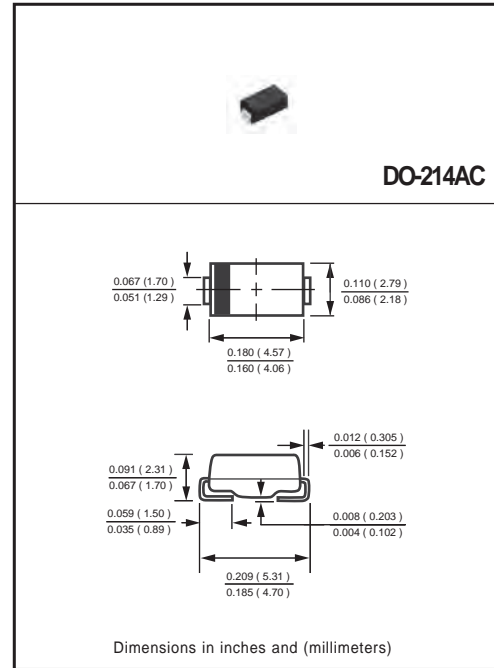

MAXIMUM RATINGS (@ TA=25 °C unless otherwise noted)

RATINGS	SYMBOL	EFM101	EFM102	EFM103	EFM104	EFM105	EFM106	EFM107	UNITS
Maximum Recurrent Peak Reverse Voltage	V _{RRM}	50	100	150	200	300	400	600	Volts
Maximum RMS Voltage	V _{RMS}	35	70	105	140	210	280	420	Volts
Maximum DC Blocking Voltage	V _{DC}	50	100	150	200	300	400	600	Volts
Maximum Average Forward Rectified Current at T _A = 55°C	I _O	1.0							Amps
Peak Forward Surge Current 8.3 ms single half sine-wave superimposed on rated load (JEDEC method)	I _{FSM}	30							Amps
Typical Current Square Time	I ² T	3.7							A ² S
Typical Thermal Resistance (Note 4)	R _{θJA}	85							°C/W
	R _{θJL}	35							
Typical Junction Capacitance (Note 2)	C _J	10							pF
Operating and Storage Temperature Range	T _J , T _{STG}	-55 to + 150							°C

ELECTRICAL CHARACTERISTICS(@TA=25 °C unless otherwise noted)

CHARACTERISTICS	SYMBOL	EFM101	EFM102	EFM103	EFM104	EFM105	EFM106	EFM107	UNITS	
Maximum Instantaneous Forward Voltage at 1.0A DC	V _F	0.95			1.25		1.50		Volts	
Maximum DC Reverse Current at Rated DC Blocking Voltage	I _R	@T _A = 25°C							5.0	μAmps
		@T _A = 150°C							2.0	mAmps
Maximum Reverse Recovery Time (Note 1)	t _{rr}	35						50	nSec	

- NOTES : 1. Reverse Recovery Test Conditions: I_F = 0.5A, I_R = -1.0A, I_{RR} = -0.25A
 2. Measured at 1 MHz and applied reverse voltage of 4.0 volts
 3. "Fully ROHS compliant", "100% Sn plating (Pb-free)".
 4. Thermal Resistance : Mounted on PCB.

RATING AND CHARACTERISTICS CURVES (EFM101 THRU EFM107)

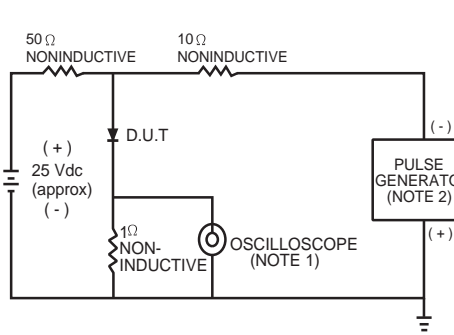

- NOTES: 1 Rise Time = 7ns max. Input Impedance = 1 megohm. 22pF.
 2. Rise Time = 10ns max. Source Impedance = 50 ohms.

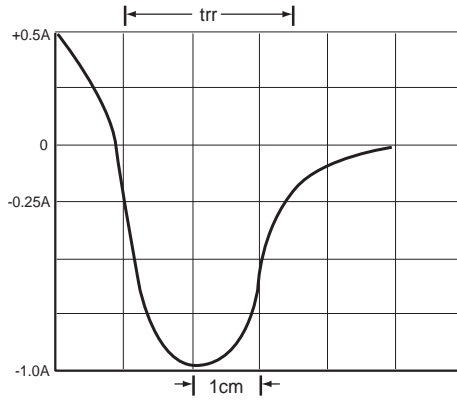

SET TIME BASE FOR 10/1 ns/cm

FIG.1 TEST CIRCUIT DIAGRAM AND REVERSE RECOVERY TIME CHARACTERISTIC

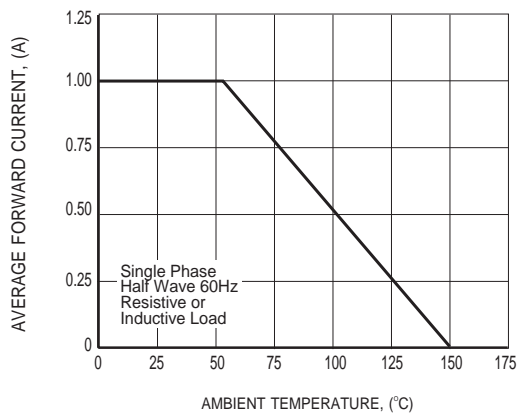

FIG.2 TYPICAL FORWARD CURRENT DERATING CURVE

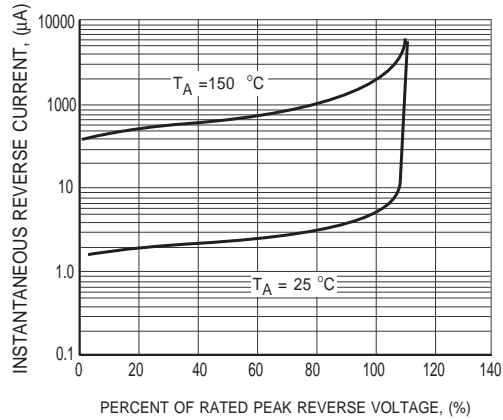

FIG.3 MAXIMUM REVERSE CHARACTERISTICS

RATING AND CHARACTERISTICS CURVES (EFM101 THRU EFM107)

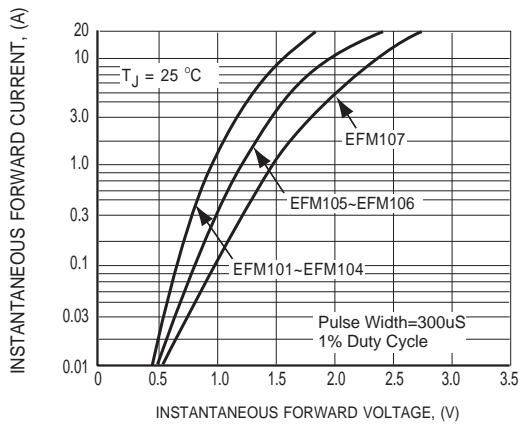

FIG.4 MAXIMUM INSTANTANEOUS FORWARD CHARACTERISTICS

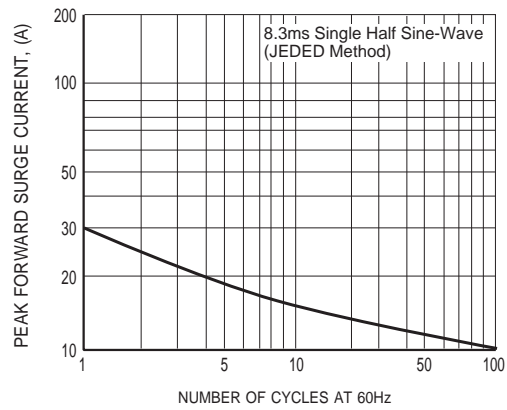

FIG.5 MAXIMUM NON-REPETITIVE FORWARD SURGE CURRENT

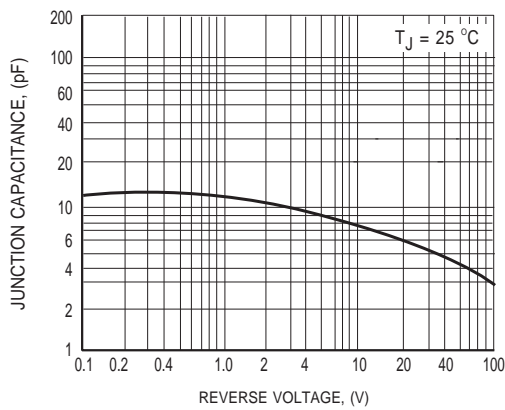
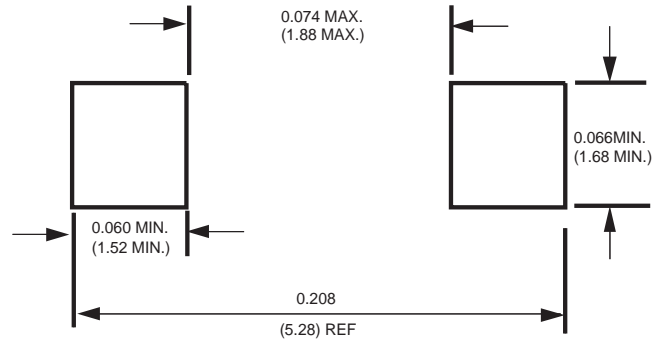

FIG.6 TYPICAL JUNCTION CAPACITANCE

Mounting Pad Layout



Dimensions in inches and (millimeters)



Attachment information about EFM10X

1. Internal Circuit



2. Marking on the body

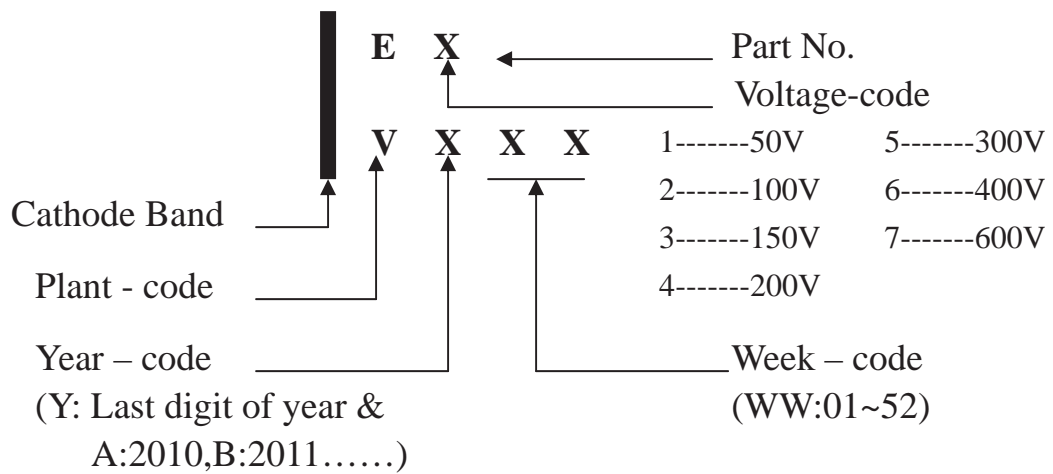



Attachment information about EFM10X

4. Items marked on the reel box and carton

4.1 On the reel (for -T & -W)

CUSTOMER

TYPE

QUANTITY

LOT NO.

Q.A.

REMARK

4.2 On the box (for -T & -W)

TYPE

QUANTITY

LOT NO.

Q.A.

4.3 On the carton

CUSTOMER

TYPE

QUANTITY

LOT NO.

REMARK

PACKAGING OF DIODE AND BRIDGE RECTIFIERS

REEL PACK

PACKAGE	PACKING CODE	EA PER REEL	EA PER INNER BOX	COMPONENT SPACE (mm)	TAPE SPACE (mm)	REEL DIA (mm)	CARTON SIZE (mm)	EA PER CARTON	GROSS WEIGHT(Kg)
SMA	-T	1,500	6,000	---	---	178	390*205*310	48,000	8.40
SMA	-W	5,000	10,000	---	---	330	360*355*360	80,000	14.20