

EFM8 Universal Bee Family

EFM8UB2 Data Sheet



The EFM8UB2, part of the Universal Bee family of MCUs, is a multi-purpose line of 8-bit microcontrollers with USB feature set.

These devices offer high value by integrating a USB peripheral interface with a high precision oscillator, clock recovery circuit, and integrated transceiver, making them ideal for any full speed USB applications with no external components required. With an efficient 8051 core and precision analog, the EFM8UB2 family is also optimal for embedded applications.

EFM8UB2 applications include the following:

- USB I/O controls, dongles
- High-speed communication bridge
- Consumer electronics
- Medical equipment

KEY FEATURES

- Pipelined 8-bit 8051 MCU Core with 48 MHz maximum operating frequency
- Up to 40 multifunction I/O pins
- Crystal-less full speed/low speed USB 2.0 compliant controller with 1 KB buffer memory
- One differential 10-bit ADC and two analog comparators
- Internal 48 MHz oscillator with $\pm 0.25\%$ accuracy with USB clock recovery supports crystal-free USB and UART operation
- 2 UARTs, SPI, 2 SMBus/I2C serial communications

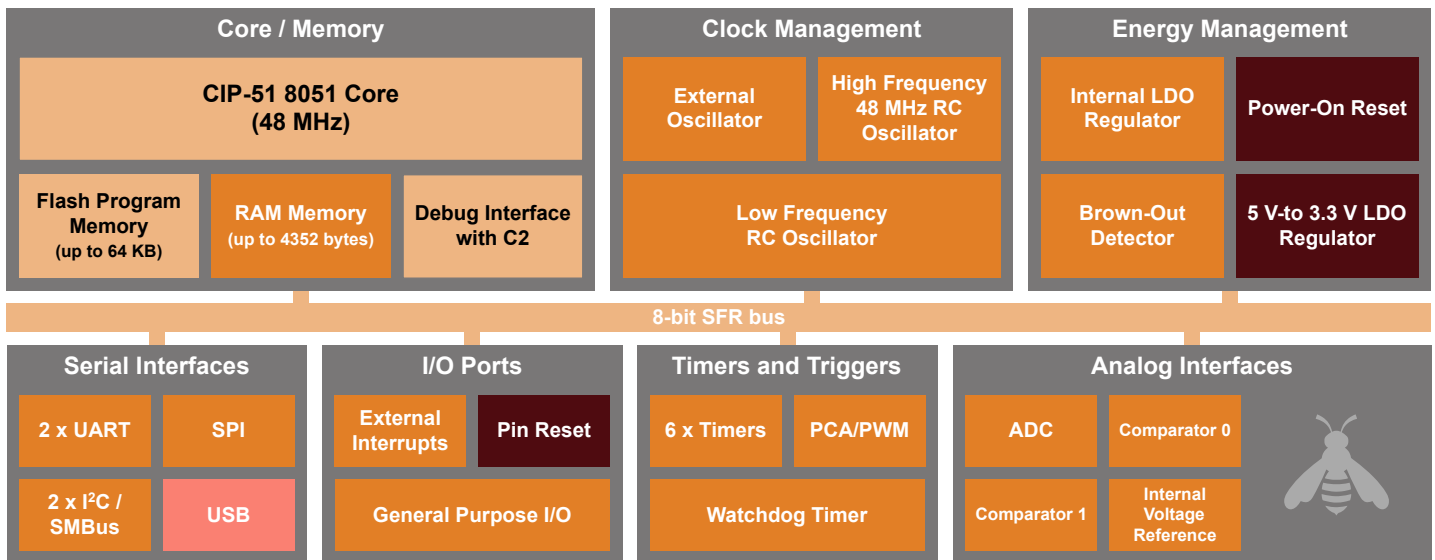

Lowest power mode with peripheral operational:

- Normal
- Idle
- Suspend
- Shutdown

1. Feature List

The EFM8UB2 highlighted features are listed below.

- Core:
 - Pipelined CIP-51 Core
 - Fully compatible with standard 8051 instruction set
 - 70% of instructions execute in 1-2 clock cycles
 - 48 MHz maximum operating frequency
- Memory:
 - Up to 64 KB flash memory, in-system re-programmable from firmware.
 - Up to 4352 bytes RAM (including 256 bytes standard 8051 RAM and 4096 bytes on-chip XRAM)
- Power:
 - Internal LDO regulator for CPU core voltage
 - Internal 5-to-3.3 V LDO allows direct connection to USB supply net
 - Power-on reset circuit and brownout detectors
- I/O: Up to 40 total multifunction I/O pins:
 - Flexible peripheral crossbar for peripheral routing
 - 10 mA source, 25 mA sink allows direct drive of LEDs
- Clock Sources:
 - Internal 48 MHz precision oscillator ($\pm 1.5\%$ accuracy without USB clock recovery, $\pm 0.25\%$ accuracy with USB clock recovery)
 - Internal 80 kHz low-frequency oscillator
 - External crystal, RC, C, and CMOS clock options
- Timers/Counters and PWM:
 - 5-channel Programmable Counter Array (PCA) supporting PWM, capture/compare, and frequency output modes with watchdog timer function
 - 6 x 16-bit general-purpose timers
- Communications and Digital Peripherals:
 - Universal Serial Bus (USB) Function Controller with eight flexible endpoint pipes, integrated transceiver, and 1 KB FIFO RAM
 - 2 x UART
 - SPI™ Master / Slave
 - 2 x SMBus™/I2C™ Master / Slave
 - External Memory Interface (EMIF)
- Analog:
 - 10-Bit Analog-to-Digital Converter (ADC0)
 - 2 x Low-current analog comparators
- On-Chip, Non-Intrusive Debugging
 - Full memory and register inspection
 - Four hardware breakpoints, single-stepping
- Pre-loaded USB bootloader
- Temperature range -40 to 85 °C
- Single power supply 2.65 to 3.6 V
- QFP48, QFP32, and QFN32 packages

With on-chip power-on reset, voltage supply monitor, watchdog timer, and clock oscillator, the EFM8UB2 devices are truly standalone system-on-a-chip solutions. The flash memory is reprogrammable in-circuit, providing non-volatile data storage and allowing field upgrades of the firmware. The on-chip debugging interface (C2) allows non-intrusive (uses no on-chip resources), full speed, in-circuit debugging using the production MCU installed in the final application. This debug logic supports inspection and modification of memory and registers, setting breakpoints, single stepping, and run and halt commands. All analog and digital peripherals are fully functional while debugging. Each device is specified for 2.65 to 3.6 V operation and is available in 32-pin QFN, 32-pin QFP, or 48-pin QFP packages. All package options are lead-free and RoHS compliant.

2. Ordering Information

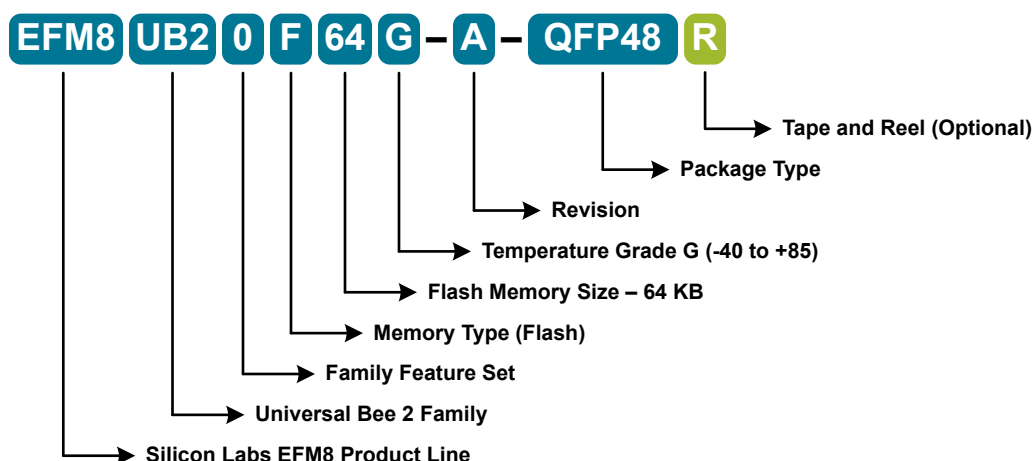

Figure 2.1. EFM8UB2 Part Numbering

All EFM8UB2 family members have the following features:

- CIP-51 Core running up to 48 MHz
- Two Internal Oscillators (48 MHz and 80 kHz)
- USB Full/Low speed Function Controller
- 5 V-In, 3.3 V-Out Regulator
- 2 SMBus/I2C Interfaces
- SPI
- 2 UARTs
- 5-Channel Programmable Counter Array (PWM, Clock Generation, Capture/Compare)
- 6 16-bit Timers
- 2 Analog Comparators
- 10-bit Differential Analog-to-Digital Converter with integrated multiplexer and temperature sensor
- Pre-loaded USB bootloader

In addition to these features, each part number in the EFM8UB2 family has a set of features that vary across the product line. The product selection guide shows the features available on each family member.

Table 2.1. Product Selection Guide

Ordering Part Number	Flash Memory (kB)	RAM (Bytes)	Digital Port I/Os (Total)	ADC0 Channels	Comparator 0 Inputs	Comparator 1 Inputs	Crystal Oscillator	External Memory Interface	Pb-free (RoHS Compliant)	Temperature Range	Package
EFM8UB20F64G-B-QFP48	64	4352	40	32	5	5	Yes	Yes	Yes	-40 to +85 °C	QFP48
EFM8UB20F64G-B-QFP32	64	4352	25	20	5	4	—	—	Yes	-40 to +85 °C	QFP32
EFM8UB20F64G-B-QFN32	64	4352	25	20	5	4	—	—	Yes	-40 to +85 °C	QFN32
EFM8UB20F32G-B-QFP48	32	2304	40	32	5	5	Yes	Yes	Yes	-40 to +85 °C	QFP48
EFM8UB20F32G-B-QFP32	32	2304	25	20	5	4	—	—	Yes	-40 to +85 °C	QFP32
EFM8UB20F32G-B-QFN32	32	2304	25	20	5	4	—	—	Yes	-40 to +85 °C	QFN32

3. System Overview

3.1 Introduction

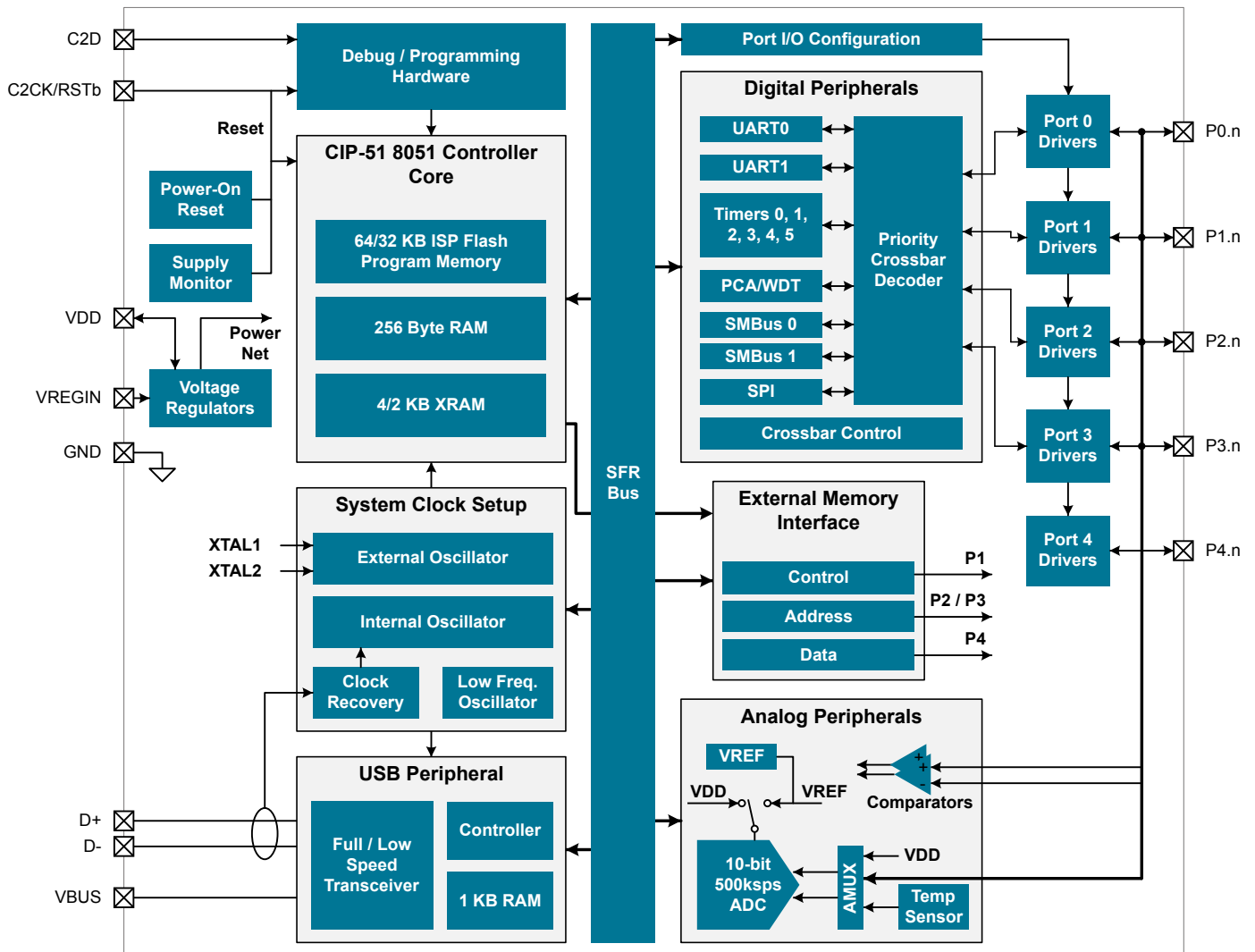

Figure 3.1. Detailed EFM8UB2 Block Diagram

This section describes the EFM8UB2 family at a high level. For more information on each module including register definitions, see the EFM8UB2 Reference Manual.

3.2 Power

All internal circuitry draws power from the VDD supply pin. External I/O pins are powered from the VIO supply voltage (or VDD on devices without a separate VIO connection), while most of the internal circuitry is supplied by an on-chip LDO regulator. Control over the device power can be achieved by enabling/disabling individual peripherals as needed. Each analog peripheral can be disabled when not in use and placed in low power mode. Digital peripherals, such as timers and serial buses, have their clocks gated off and draw little power when they are not in use.

Table 3.1. Power Modes

Power Mode	Details	Mode Entry	Wake-Up Sources
Normal	Core and all peripherals clocked and fully operational	—	—
Idle	<ul style="list-style-type: none"> Core halted All peripherals clocked and fully operational Code resumes execution on wake event 	Set IDLE bit in PCON0	Any interrupt
Suspend	<ul style="list-style-type: none"> Core and peripheral clocks halted Code resumes execution on wake event 	<ol style="list-style-type: none"> Switch SYSCLK to HFOSC0 Set SUSPEND bit in HFO0CN 	USB0 Bus Activity
Stop	<ul style="list-style-type: none"> All internal power nets shut down Pins retain state Exit on any reset source 	Set STOP bit in PCON0	Any reset source
Shutdown	<ul style="list-style-type: none"> All internal power nets shut down 5V regulator remains active (if enabled) Pins retain state Exit on pin or power-on reset 	<ol style="list-style-type: none"> Set STOPCF bit in REG01CN Set STOP bit in PCON0 	<ul style="list-style-type: none"> RSTb pin reset Power-on reset

3.3 I/O

Digital and analog resources are externally available on the device's multi-purpose I/O pins. Port pins P0.0-P3.7 can be defined as general-purpose I/O (GPIO), assigned to one of the internal digital resources through the crossbar or dedicated channels, or assigned to an analog function. Port pins P4.0-P4.7 can be used as GPIO. Additionally, the C2 Interface Data signal (C2D) is shared with P3.0 on some packages.

- Up to 40 multi-functions I/O pins, supporting digital and analog functions.
- Flexible priority crossbar decoder for digital peripheral assignment.
- Two direct-pin interrupt sources with dedicated interrupt vectors (INT0 and INT1) available on P0 pins.

3.4 Clocking

The CPU core and peripheral subsystem may be clocked by both internal and external oscillator resources. By default, the system clock comes up running from the 48 MHz oscillator divided by 4, then divided by 8 (1.5 MHz).

- Provides clock to core and peripherals.
- 48 MHz internal oscillator (HFOSC0), accurate to $\pm 1.5\%$ over supply and temperature corners: accurate to $\pm 0.25\%$ when using USB clock recovery.
- 80 kHz low-frequency oscillator (LFOSC0).
- External RC, C, CMOS, and high-frequency crystal clock options (EXTCLK) for QFP48 packages.
- External CMOS clock option (EXTCLK) for QFP32 and QFN32 packages.
- Internal oscillator has clock divider with eight settings for flexible clock scaling: 1, 2, 4, or 8.

3.5 Counters/Timers and PWM

Programmable Counter Array (PCA0)

The programmable counter array (PCA) provides multiple channels of enhanced timer and PWM functionality while requiring less CPU intervention than standard counter/timers. The PCA consists of a dedicated 16-bit counter/timer and one 16-bit capture/compare module for each channel. The counter/timer is driven by a programmable timebase that has flexible external and internal clocking options. Each capture/compare module may be configured to operate independently in one of five modes: Edge-Triggered Capture, Software Timer, High-Speed Output, Frequency Output, or Pulse-Width Modulated (PWM) Output. Each capture/compare module has its own associated I/O line (CEXn) which is routed through the crossbar to port I/O when enabled.

- 16-bit time base.
- Programmable clock divisor and clock source selection.
- Up to five independently-configurable channels
- 8- or 16-bit PWM modes (edge-aligned operation).
- Frequency output mode.
- Capture on rising, falling or any edge.
- Compare function for arbitrary waveform generation.
- Software timer (internal compare) mode.
- Integrated watchdog timer.

Timers (Timer 0, Timer 1, Timer 2, Timer 3, Timer 4, and Timer 5)

Several counter/timers are included in the device: two are 16-bit counter/timers compatible with those found in the standard 8051, and the rest are 16-bit auto-reload timers for timing peripherals or for general purpose use. These timers can be used to measure time intervals, count external events and generate periodic interrupt requests. Timer 0 and Timer 1 are nearly identical and have four primary modes of operation. The other timers offer both 16-bit and split 8-bit timer functionality with auto-reload and capture capabilities.

Timer 0 and Timer 1 include the following features:

- Standard 8051 timers, supporting backwards-compatibility with firmware and hardware.
- Clock sources include SYSCLK, SYSCLK divided by 12, 4, or 48, the External Clock divided by 8, or an external pin.
- 8-bit auto-reload counter/timer mode
- 13-bit counter/timer mode
- 16-bit counter/timer mode
- Dual 8-bit counter/timer mode (Timer 0)

Timer 2, Timer 3, Timer 4, and Timer 5 are 16-bit timers including the following features:

- Clock sources include SYSCLK, SYSCLK divided by 12, or the External Clock divided by 8.
- 16-bit auto-reload timer mode
- Dual 8-bit auto-reload timer mode
- USB start-of-frame or falling edge of LFOSC0 capture (Timer 2 and Timer 3)

Watchdog Timer (WDT0)

The device includes a programmable watchdog timer (WDT) integrated within the PCA0 peripheral. A WDT overflow forces the MCU into the reset state. To prevent the reset, the WDT must be restarted by application software before overflow. If the system experiences a software or hardware malfunction preventing the software from restarting the WDT, the WDT overflows and causes a reset. Following a reset, the WDT is automatically enabled and running with the default maximum time interval. If needed, the WDT can be disabled by system software. The state of the RSTb pin is unaffected by this reset.

The Watchdog Timer integrated in the PCA0 peripheral has the following features:

- Programmable timeout interval
- Runs from the selected PCA clock source
- Automatically enabled after any system reset

3.6 Communications and Other Digital Peripherals

Universal Serial Bus (USB0)

The USB0 module provides Full/Low Speed function for USB peripheral implementations. The USB function controller (USB0) consists of a Serial Interface Engine (SIE), USB transceiver (including matching resistors and configurable pull-up resistors), 1 KB FIFO block, and clock recovery mechanism for crystal-less operation. No external components are required. The USB0 module is Universal Serial Bus Specification 2.0 compliant.

The USB0 module includes the following features:

- Full and Low Speed functionality.
- Implements 4 bidirectional endpoints.
- USB 2.0 compliant USB peripheral support (no host capability).
- Direct module access to 1 KB of RAM for FIFO memory.
- Clock recovery to meet USB clocking requirements with no external components.

Universal Asynchronous Receiver/Transmitter (UART0)

UART0 is an asynchronous, full duplex serial port offering modes 1 and 3 of the standard 8051 UART. Enhanced baud rate support allows a wide range of clock sources to generate standard baud rates. Received data buffering allows UART0 to start reception of a second incoming data byte before software has finished reading the previous data byte.

The UART module provides the following features:

- Asynchronous transmissions and receptions.
- Baud rates up to $\text{SYSCLK}/2$ (transmit) or $\text{SYSCLK}/8$ (receive).
- 8- or 9-bit data.
- Automatic start and stop generation.
- Single-byte FIFO on transmit and receive.

Universal Asynchronous Receiver/Transmitter (UART1)

UART1 is an asynchronous, full duplex serial port offering a variety of data formatting options. A dedicated baud rate generator with a 16-bit timer and selectable prescaler is included, which can generate a wide range of baud rates. A received data FIFO allows UART1 to receive multiple bytes before data is lost and an overflow occurs.

UART1 provides the following features:

- Asynchronous transmissions and receptions.
- Dedicated baud rate generator supports baud rates up to $\text{SYSCLK}/2$ (transmit) or $\text{SYSCLK}/8$ (receive)
- 5, 6, 7, 8, or 9 bit data.
- Automatic start and stop generation.
- Automatic parity generation and checking.
- Three byte FIFO on receive.

Serial Peripheral Interface (SPI0)

The serial peripheral interface (SPI) module provides access to a flexible, full-duplex synchronous serial bus. The SPI can operate as a master or slave device in both 3-wire or 4-wire modes, and supports multiple masters and slaves on a single SPI bus. The slave-select (NSS) signal can be configured as an input to select the SPI in slave mode, or to disable master mode operation in a multi-master environment, avoiding contention on the SPI bus when more than one master attempts simultaneous data transfers. NSS can also be configured as a firmware-controlled chip-select output in master mode, or disabled to reduce the number of pins required. Additional general purpose port I/O pins can be used to select multiple slave devices in master mode.

The SPI module includes the following features:

- Supports 3- or 4-wire operation in master or slave modes.
- Supports external clock frequencies up to $\text{SYSCLK} / 2$ in master mode and $\text{SYSCLK} / 10$ in slave mode.
- Support for four clock phase and polarity options.
- 8-bit dedicated clock rate generator.
- Support for multiple masters on the same data lines.

System Management Bus / I2C (SMB0 and SMB1)

The SMBus I/O interface is a two-wire, bi-directional serial bus. The SMBus is compliant with the System Management Bus Specification, version 1.1, and compatible with the I²C serial bus.

The SMBus modules include the following features:

- Standard (up to 100 kbps) and Fast (400 kbps) transfer speeds.
- Support for master, slave, and multi-master modes.
- Hardware synchronization and arbitration for multi-master mode.
- Clock low extending (clock stretching) to interface with faster masters.
- Hardware support for 7-bit slave and general call address recognition.
- Firmware support for 10-bit slave address decoding.
- Ability to inhibit all slave states.
- Programmable data setup/hold times.

External Memory Interface (EMIF0)

The External Memory Interface (EMIF) enables access of off-chip memories and memory-mapped devices connected to the GPIO ports. The external memory space may be accessed using the external move instruction (MOVX) with the target address specified in either 8-bit or 16-bit formats.

- Supports multiplexed and non-multiplexed memory access.
- Four external memory modes:
 - Internal only.
 - Split mode without bank select.
 - Split mode with bank select.
 - External only
- Configurable ALE (address latch enable) timing.
- Configurable address setup and hold times.
- Configurable write and read pulse widths.

3.7 Analog

10-Bit Analog-to-Digital Converter (ADC0)

The ADC is a successive-approximation-register (SAR) ADC with 10-bit mode, integrated track-and hold and a programmable window detector. The ADC is fully configurable under software control via several registers. The ADC may be configured to measure different signals using the analog multiplexer. The voltage reference for the ADC is selectable between internal and external reference sources.

The ADC module is a Successive Approximation Register (SAR) Analog to Digital Converter (ADC). The key features of this ADC module are:

- Up to 32 external inputs.
- Differential or Single-ended 10-bit operation.
- Supports an output update rate of 500 ksps samples per second.
- Asynchronous hardware conversion trigger, selectable between software, external I/O and internal timer sources.
- Output data window comparator allows automatic range checking.
- Two tracking mode options with programmable tracking time.
- Conversion complete and window compare interrupts supported.
- Flexible output data formatting.
- Voltage reference selectable from external reference pin, on-chip precision reference (driven externally on reference pin), or VDD supply.
- Integrated temperature sensor.

Low Current Comparators (CMP0, CMP1)

Analog comparators are used to compare the voltage of two analog inputs, with a digital output indicating which input voltage is higher. External input connections to device I/O pins and internal connections are available through separate multiplexers on the positive and negative inputs. Hysteresis, response time, and current consumption may be programmed to suit the specific needs of the application.

The comparator module includes the following features:

- Up to 5 external positive inputs.
- Up to 5 external negative inputs.
- Synchronous and asynchronous outputs can be routed to pins via crossbar.
- Programmable hysteresis between 0 and +/-20 mV.
- Programmable response time.
- Interrupts generated on rising, falling, or both edges.

3.8 Reset Sources

Reset circuitry allows the controller to be easily placed in a predefined default condition. On entry to this reset state, the following occur:

- The core halts program execution.
- Module registers are initialized to their defined reset values unless the bits reset only with a power-on reset.
- External port pins are forced to a known state.
- Interrupts and timers are disabled.

All registers are reset to the predefined values noted in the register descriptions unless the bits only reset with a power-on reset. The contents of RAM are unaffected during a reset; any previously stored data is preserved as long as power is not lost. The Port I/O latches are reset to 1 in open-drain mode. Weak pullups are enabled during and after the reset. For Supply Monitor and power-on resets, the RSTb pin is driven low until the device exits the reset state. On exit from the reset state, the program counter (PC) is reset, and the system clock defaults to an internal oscillator. The Watchdog Timer is enabled, and program execution begins at location 0x0000.

Reset sources on the device include:

- Power-on reset
- External reset pin
- Comparator reset
- Software-triggered reset
- Supply monitor reset (monitors VDD supply)
- Watchdog timer reset
- Missing clock detector reset
- Flash error reset
- USB reset

3.9 Debugging

The EFM8UB2 devices include an on-chip Silicon Labs 2-Wire (C2) debug interface to allow flash programming and in-system debugging with the production part installed in the end application. The C2 interface uses a clock signal (C2CK) and a bi-directional C2 data signal (C2D) to transfer information between the device and a host system. See the C2 Interface Specification for details on the C2 protocol.

3.10 Bootloader

All devices come pre-programmed with a USB bootloader. This bootloader resides in the last three pages of code flash, which includes the code security page; it can be erased if it is not needed.

The byte before the Lock Byte is the Bootloader Signature Byte. Setting this byte to a value of 0xA5 indicates the presence of the bootloader in the system. Any other value in this location indicates that the bootloader is not present in flash.

When a bootloader is present, the device will jump to the bootloader vector after any reset, allowing the bootloader to run. The bootloader then determines if the device should stay in bootload mode or jump to the reset vector located at 0x0000. When the bootloader is not present, the device will jump to the reset vector of 0x0000 after any reset.

More information about the bootloader protocol and usage can be found in *AN945: EFM8 Factory Bootloader User Guide*. Application notes can be found on the Silicon Labs website (www.silabs.com/8bit-appnotes) or within Simplicity Studio by using the [Application Notes] tile.

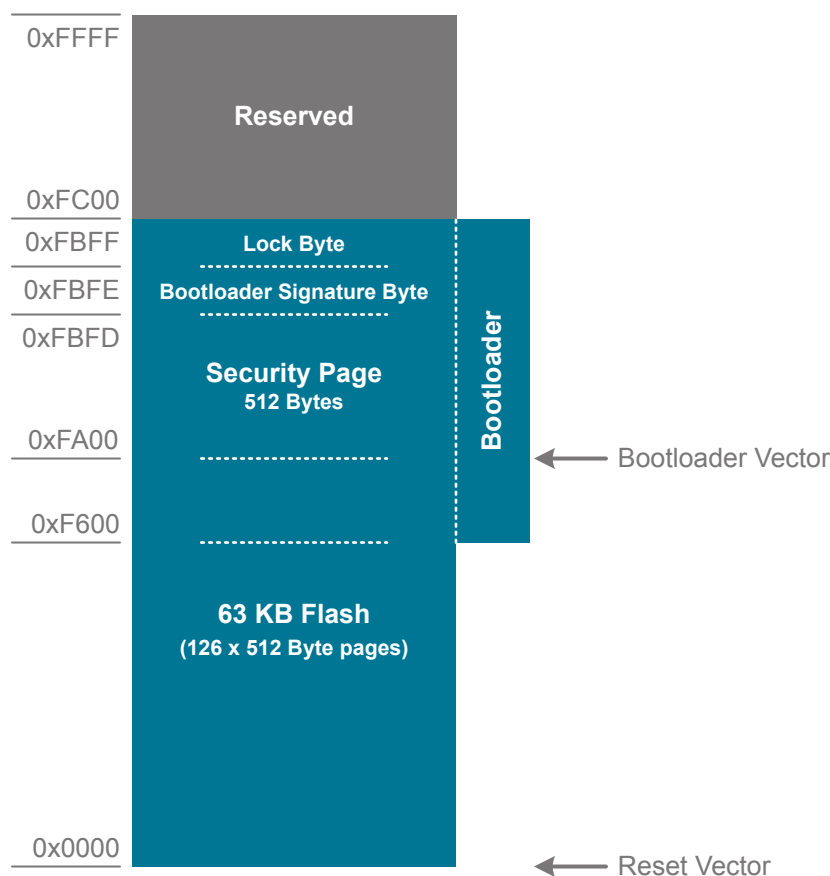

Figure 3.2. Flash Memory Map with Bootloader—64 KB Devices

Table 3.2. Summary of Pins for Bootloader Communication

Bootloader	Pins for Bootload Communication
UART	TX – P0.4
	RX – P0.5
USB	VBUS
	D+
	D-

Table 3.3. Summary of Pins for Bootload Mode Entry

Device Package	Pin for Bootload Mode Entry
QFN48	P3.7
QFP32	P3.0 / C2D
QFN32	P3.0 / C2D

4. Electrical Specifications

4.1 Electrical Characteristics

All electrical parameters in all tables are specified under the conditions listed in [Table 4.1 Recommended Operating Conditions on page 11](#), unless stated otherwise.

4.1.1 Recommended Operating Conditions

Table 4.1. Recommended Operating Conditions

Parameter	Symbol	Test Condition	Min	Typ	Max	Unit
Operating Supply Voltage on VDD	V _{DD}		2.7 ²	3.3	3.6	V
Operating Supply Voltage on VREGIN	V _{REGIN}		2.7	—	5.25	V
System Clock Frequency	f _{SYSCLK}		0	—	48	MHz
Operating Ambient Temperature	T _A		-40	—	85	°C

Note:

1. All voltages with respect to GND
2. The USB specification requires 3.0 V minimum supply voltage.

4.1.2 Power Consumption

Table 4.2. Power Consumption

Parameter	Symbol	Test Condition	Min	Typ	Max	Unit
Digital Core Supply Current						
Normal Mode—Full speed with code executing from flash	I _{DD}	F _{SYSCLK} = 48 MHz ²	—	12	14	mA
		F _{SYSCLK} = 24 MHz ²	—	7	8	mA
		F _{SYSCLK} = 80 kHz ³	—	280	—	μA
Idle Mode—Core halted with peripherals running	I _{DD}	F _{SYSCLK} = 48 MHz ²	—	6.5	8	mA
		F _{SYSCLK} = 24 MHz ²	—	3.5	5	mA
		F _{SYSCLK} = 80 kHz ³	—	220	—	μA
Suspend Mode—Core halted and high frequency clocks stopped, Supply monitor off. Regulators in low-power mode.	I _{DD}	LFO Running	—	105	—	μA
		LFO Stopped	—	100	—	μA
Stop Mode—Core halted and all clocks stopped, Regulators in low-power mode, Supply monitor off.	I _{DD}		—	100	—	μA
Shutdown Mode—Core halted and all clocks stopped, Regulators Off, Supply monitor off.	I _{DD}		—	0.25	—	μA
Analog Peripheral Supply Currents						
High-Frequency Oscillator 0	I _{HFOSC0}	Operating at 48 MHz, T _A = 25 °C	—	900	—	μA
Low-Frequency Oscillator	I _{LFOSC}	Operating at 80 kHz, T _A = 25 °C	—	5	—	μA
ADC0 Supply Current	I _{ADC}	Operating at 500 ksps V _{DD} = 3.0 V	—	750	1000	μA
On-chip Precision Reference	I _{VREFP}		—	75	—	μA
Temperature Sensor	I _{TSENSE}		—	35	—	μA
Comparator 0 (CMP0, CMP1)	I _{CMP}	CPMD = 11	—	1	—	μA
		CPMD = 10	—	4	—	μA
		CPMD = 01	—	10	—	μA
		CPMD = 00	—	20	—	μA
Voltage Supply Monitor (VMON0)	I _{VMON}		—	15	50	μA
Regulator Bias Currents	I _{VREG}	Both Regulators in Normal Mode	—	200	—	μA
		Both Regulators in Low Power Mode	—	100	—	μA
		5 V Regulator Off, Internal LDO in Low Power Mode	—	150	—	μA
USB (USB0) Full-Speed	I _{USB}	Active	—	8	—	mA

Parameter	Symbol	Test Condition	Min	Typ	Max	Unit
Note:						
1. Currents are additive. For example, where I_{DD} is specified and the mode is not mutually exclusive, enabling the functions increases supply current by the specified amount.						
2. Includes supply current from regulators, supply monitor, and High Frequency Oscillator.						
3. Includes supply current from regulators, supply monitor, and Low Frequency Oscillator.						

4.1.3 Reset and Supply Monitor

Table 4.3. Reset and Supply Monitor

Parameter	Symbol	Test Condition	Min	Typ	Max	Unit
VDD Supply Monitor Threshold	V_{VDDM}		2.60	2.65	2.70	V
Power-On Reset (POR) Threshold	V_{POR}	Rising Voltage on VDD	—	1.4	—	V
		Falling Voltage on VDD	0.75	—	1.36	V
VDD Ramp Time	t_{RMP}	Time to $V_{DD} > 2.7$ V	—	—	1	ms
Reset Delay from POR	t_{POR}	Relative to $V_{DD} > V_{POR}$	3	10	31	ms
Reset Delay from non-POR source	t_{RST}	Time between release of reset source and code execution	—	—	250	μ s
RST Low Time to Generate Reset	t_{RSTL}		15	—	—	μ s
Missing Clock Detector Response Time (final rising edge to reset)	t_{MCD}	$F_{SYSCLK} > 1$ MHz	80	580	800	μ s
VDD Supply Monitor Turn-On Time	t_{MON}		—	—	100	μ s

4.1.4 Flash Memory

Table 4.4. Flash Memory

Parameter	Symbol	Test Condition	Min	Typ	Max	Units
Write Time ¹	t_{WRITE}	One Byte	10	15	20	μ s
Erase Time ¹	t_{ERASE}	One Page	10	15	22.5	ms
V_{DD} Voltage During Programming ²	V_{PROG}		2.7	—	3.6	V
Endurance (Write/Erase Cycles)	N_{WE}		10k	100k	—	Cycles
CRC Calculation Time	t_{CRC}	One 256-Byte Block SYSCLK = 48 MHz	—	5.5	—	μ s
Note:						
1. Does not include sequencing time before and after the write/erase operation, which may be multiple SYSCLK cycles.						
2. Flash can be safely programmed at any voltage above the supply monitor threshold (V_{VDDM}).						
3. Data Retention Information is published in the Quarterly Quality and Reliability Report.						

4.1.5 Internal Oscillators

Table 4.5. Internal Oscillators

Parameter	Symbol	Test Condition	Min	Typ	Max	Unit
High Frequency Oscillator 0 (48 MHz)						
Oscillator Frequency	f_{HFOSC0}	Full Temperature and Supply Range	47.3	48	48.7	MHz
Power Supply Sensitivity	PSS_{HFOSC0}	$T_A = 25\text{ }^\circ\text{C}$	—	110	—	ppm/V
Temperature Sensitivity	TS_{HFOSC0}	$V_{DD} = 3.0\text{ V}$	—	25	—	ppm/ $^\circ\text{C}$
Low Frequency Oscillator (80 kHz)						
Oscillator Frequency	f_{LFOSC}	Full Temperature and Supply Range	75	80	85	kHz
Power Supply Sensitivity	PSS_{LFOSC}	$T_A = 25\text{ }^\circ\text{C}$	—	0.05	—	%/V
Temperature Sensitivity	TS_{LFOSC}	$V_{DD} = 3.0\text{ V}$	—	65	—	ppm/ $^\circ\text{C}$

4.1.6 Crystal Oscillator

Table 4.6. Crystal Oscillator

Parameter	Symbol	Test Condition	Min	Typ	Max	Unit
Crystal Frequency	f_{XTAL}		0.02	—	30	MHz

4.1.7 External Clock Input

Table 4.7. External Clock Input

Parameter	Symbol	Test Condition	Min	Typ	Max	Unit
External Input CMOS Clock Frequency (at EXTCLK pin)	f_{CMOS}		0	—	48	MHz

4.1.8 ADC

Table 4.8. ADC

Parameter	Symbol	Test Condition	Min	Typ	Max	Unit
Resolution	N_{bits}			10		Bits
Throughput Rate	f_S		—	—	500	ksp/s
Tracking Time	t_{TRK}		300	—	—	ns
SAR Clock Frequency	f_{SAR}		—	—	8.33	MHz
Conversion Time	t_{CNV}	10-Bit Conversion,	13	—	—	Clocks
Sample/Hold Capacitor	C_{SAR}		—	30	—	pF
Input Mux Impedance	R_{MUX}		—	5	—	k Ω
Voltage Reference Range	V_{REF}		1	—	V_{DD}	V
Input Voltage Range ¹	V_{IN}	Single-Ended (AIN+ - GND)	0	—	V_{REF}	V
		Differential (AIN+ - AIN-)	$-V_{\text{REF}}$	—	V_{REF}	V
Power Supply Rejection Ratio	PSRR_{ADC}		—	70	—	dB
DC Performance, $V_{\text{REF}} = 2.4 \text{ V}$						
Integral Nonlinearity	INL		—	± 0.5	± 1	LSB
Differential Nonlinearity (Guaranteed Monotonic)	DNL		—	± 0.5	± 1	LSB
Offset Error	E_{OFF}		-2	0	2	LSB
Offset Temperature Coefficient	TC_{OFF}		—	0.005	—	LSB/ $^{\circ}\text{C}$
Slope Error	E_{M}		—	-0.2	± 0.5	%
Dynamic Performance 10 kHz Sine Wave Input 1dB below full scale, $V_{\text{REF}} = 2.4 \text{ V}$						
Signal-to-Noise	SNR		55	58	—	dB
Signal-to-Noise Plus Distortion	SNDR		55	58	—	dB
Total Harmonic Distortion (Up to 5th Harmonic)	THD		—	-73	—	dB
Spurious-Free Dynamic Range	SFDR		—	78	—	dB
Note:						
1. Absolute input pin voltage is limited by the VDD and GND supply pins.						

4.1.9 Voltage Reference

Table 4.9. Voltage Reference

Parameter	Symbol	Test Condition	Min	Typ	Max	Unit
On-chip Precision Reference						
Output Voltage	V_{REFP}	$T = 25\text{ }^{\circ}\text{C}$	2.38	2.42	2.46	V
Turn-on Time, settling to 0.5 LSB	t_{VREFP}	4.7 μF tantalum + 0.1 μF ceramic bypass on VREF pin	—	3	—	ms
		0.1 μF ceramic bypass on VREF pin	—	100	—	μs
Load Regulation	LR_{VREFP}	Load = 0 to 200 μA to GND	—	360	—	$\mu\text{V} / \mu\text{A}$
Short-circuit current	ISC_{VREFP}		—	—	8	mA
Power Supply Rejection	$PSRR_{VREFP}$		—	140	—	ppm/V
External Reference						
Input Current	I_{EXTREF}	Sample Rate = 500 ksps; $V_{REF} = 3.0\text{ V}$	—	9	—	μA

4.1.10 Temperature Sensor

Table 4.10. Temperature Sensor

Parameter	Symbol	Test Condition	Min	Typ	Max	Unit
Offset	V_{OFF}	$T_A = 0\text{ }^{\circ}\text{C}$	—	764	—	mV
Offset Error ¹	E_{OFF}	$T_A = 0\text{ }^{\circ}\text{C}$	—	15	—	mV
Slope	M		—	2.87	—	$\text{mV}/^{\circ}\text{C}$
Slope Error ¹	E_M		—	120	—	$\mu\text{V}/^{\circ}\text{C}$
Linearity			—	0.5	—	$^{\circ}\text{C}$
Turn-on Time			—	1.8	—	μs
Note:						
1. Represents one standard deviation from the mean.						

4.1.11 5 V Voltage Regulator

Table 4.11. 5V Voltage Regulator

Parameter	Symbol	Test Condition	Min	Typ	Max	Unit
Input Voltage Range ¹	V _{REGIN}		2.7	—	5.25	V
Output Voltage on VDD ²	V _{REGOUT}	Output Current = 1 to 100 mA	3.0	3.3	3.6	V
Output Current ²	I _{REGOUT}		—	—	100	mA

Note:

1. Input range specified for regulation. When an external regulator is used, V_{REGIN} should be tied to VDD.
2. Output current is total regulator output, including any current required by the device.

4.1.12 Comparators

Table 4.12. Comparators

Parameter	Symbol	Test Condition	Min	Typ	Max	Unit
Response Time, CPMD = 00 (Highest Speed)	t_{RESP0}	+100 mV Differential	—	100	—	ns
		-100 mV Differential	—	250	—	ns
Response Time, CPMD = 11 (Low- est Power)	t_{RESP3}	+100 mV Differential	—	1.05	—	μ s
		-100 mV Differential	—	5.2	—	μ s
Positive Hysteresis Mode 0 (CPMD = 00)	HYS_{CP+}	CPHYP = 00	—	0.4	—	mV
		CPHYP = 01	—	8	—	mV
		CPHYP = 10	—	16	—	mV
		CPHYP = 11	—	32	—	mV
Negative Hysteresis Mode 0 (CPMD = 00)	HYS_{CP-}	CPHYN = 00	—	-0.4	—	mV
		CPHYN = 01	—	-8	—	mV
		CPHYN = 10	—	-16	—	mV
		CPHYN = 11	—	-32	—	mV
Positive Hysteresis Mode 1 (CPMD = 01)	HYS_{CP+}	CPHYP = 00	—	0.5	—	mV
		CPHYP = 01	—	6	—	mV
		CPHYP = 10	—	12	—	mV
		CPHYP = 11	—	24	—	mV
Negative Hysteresis Mode 1 (CPMD = 01)	HYS_{CP-}	CPHYN = 00	—	-0.5	—	mV
		CPHYN = 01	—	-6	—	mV
		CPHYN = 10	—	-12	—	mV
		CPHYN = 11	—	-24	—	mV
Positive Hysteresis Mode 2 (CPMD = 10)	HYS_{CP+}	CPHYP = 00	—	0.7	—	mV
		CPHYP = 01	—	4.5	—	mV
		CPHYP = 10	—	9	—	mV
		CPHYP = 11	—	18	—	mV
Negative Hysteresis Mode 2 (CPMD = 10)	HYS_{CP-}	CPHYN = 00	—	-0.6	—	mV
		CPHYN = 01	—	-4.5	—	mV
		CPHYN = 10	—	-9	—	mV
		CPHYN = 11	—	-18	—	mV
Positive Hysteresis Mode 3 (CPMD = 11)	HYS_{CP+}	CPHYP = 00	—	1.5	—	mV
		CPHYP = 01	—	4	—	mV
		CPHYP = 10	—	8	—	mV
		CPHYP = 11	—	16	—	mV

Parameter	Symbol	Test Condition	Min	Typ	Max	Unit
Negative Hysteresis Mode 3 (CPMD = 11)	HYS _{CP-}	CPHYN = 00	—	-1.5	—	mV
		CPHYN = 01	—	-4	—	mV
		CPHYN = 10	—	-8	—	mV
		CPHYN = 11	—	-16	—	mV
Input Range (CP+ or CP-)	V _{IN}		-0.25	—	V _{DD} +0.25	V
Input Pin Capacitance	C _{CP}		—	7.5	—	pF
Common-Mode Rejection Ratio	CMRR _{CP}		—	60	—	dB
Power Supply Rejection Ratio	PSRR _{CP}		—	60	—	dB
Input Offset Voltage	V _{OFF}	T _A = 25 °C	-10	0	10	mV

4.1.13 Port I/O

Table 4.13. Port I/O

Parameter	Symbol	Test Condition	Min	Typ	Max	Unit
Output High Voltage	V _{OH}	I _{OH} = -3 mA	V _{DD} - 0.7	—	—	V
		I _{OH} = -10 μA	V _{DD} - 0.1	—	—	V
Output Low Voltage	V _{OL}	I _{OL} = 8.5 mA	—	—	0.6	V
		I _{OL} = 10 μA	—	—	0.1	V
Input High Voltage	V _{IH}		2.0	—	—	V
Input Low Voltage	V _{IL}		—	—	0.8	V
Pin Capacitance	C _{IO}		—	7	—	pF
Weak Pull-Up Current (V _{IN} = 0 V)	I _{PU}	V _{DD} = 3.6	-50	-15	—	μA
Input Leakage (Pullups off or Analog)	I _{LK}	GND < V _{IN} < V _{DD}	-1	—	1	μA
Input Leakage Current with V _{IN} above V _{DD}	I _{LK}	V _{DD} < V _{IN} < V _{DD} +2.0 V	0	5	150	μA

4.1.14 USB Transceiver

Table 4.14. USB Transceiver

Parameter	Symbol	Test Condition	Min	Typ	Max	Unit
VBUS Detection Input Low Voltage	V _{BUS_L}		—	—	1.0	V
VBUS Detection Input High Voltage	V _{BUS_H}		3.0	—	—	V
Transmitter						
Output High Voltage	V _{OH}	V _{DD} ≥3.0V	2.8	—	—	V
Output Low Voltage	V _{OL}	V _{DD} ≥3.0V	—	—	0.8	V
Output Crossover Point	V _{CRS}		1.3	—	2.0	V
Output Impedance	Z _{DRV}	Driving High	—	38	—	Ω
		Driving Low	—	38	—	
Pull-up Resistance	R _{PU}	Full Speed (D+ Pull-up)	1.425	1.5	1.575	kΩ
		Low Speed (D- Pull-up)				
Output Rise Time	T _R	Low Speed	75	—	300	ns
		Full Speed	4	—	20	ns
Output Fall Time	T _F	Low Speed	75	—	300	ns
		Full Speed	4	—	20	ns
Receiver						V
Differential Input Sensitivity	V _{DI}	(D+) - (D-)	0.2	—	—	V
Differential Input Common Mode Range	V _{CM}		0.8	—	2.5	V
Input Leakage Current	I _L	Pullups Disabled	—	<1.0	—	μA
Refer to the USB Specification for timing diagrams and symbol definitions.						

4.1.15 SMBus

Table 4.15. SMBus Peripheral Timing Performance (Master Mode)

Parameter	Symbol	Test Condition	Min	Typ	Max	Unit
Standard Mode (100 kHz Class)						
I2C Operating Frequency	f_{I2C}		0	—	70^2	kHz
SMBus Operating Frequency	f_{SMB}		40^1	—	70^2	kHz
Bus Free Time Between STOP and START Conditions	t_{BUF}		9.4	—	—	μs
Hold Time After (Repeated) START Condition	$t_{HD:STA}$		4.7	—	—	μs
Repeated START Condition Setup Time	$t_{SU:STA}$		9.4	—	—	μs
STOP Condition Setup Time	$t_{SU:STO}$		9.4	—	—	μs
Data Hold Time	$t_{HD:DAT}$		0	—	—	μs
Data Setup Time	$t_{SU:DAT}$		4.7	—	—	μs
Detect Clock Low Timeout	$t_{TIMEOUT}$		25	—	—	ms
Clock Low Period	t_{LOW}		4.7	—	—	μs
Clock High Period	t_{HIGH}		9.4	—	50^3	μs
Fast Mode (400 kHz Class)						
I2C Operating Frequency	f_{I2C}		0	—	256^2	kHz
SMBus Operating Frequency	f_{SMB}		40^1	—	256^2	kHz
Bus Free Time Between STOP and START Conditions	t_{BUF}		2.6	—	—	μs
Hold Time After (Repeated) START Condition	$t_{HD:STA}$		1.3	—	—	μs
Repeated START Condition Setup Time	$t_{SU:STA}$		2.6	—	—	μs
STOP Condition Setup Time	$t_{SU:STO}$		2.6	—	—	μs
Data Hold Time	$t_{HD:DAT}$		0	—	—	μs
Data Setup Time	$t_{SU:DAT}$		1.3	—	—	μs
Detect Clock Low Timeout	$t_{TIMEOUT}$		25	—	—	ms
Clock Low Period	t_{LOW}		1.3	—	—	μs
Clock High Period	t_{HIGH}		2.6	—	50^3	μs

Note:

1. The minimum SMBus frequency is limited by the maximum Clock High Period requirement of the SMBus specification.
2. The maximum I2C and SMBus frequencies are limited by the minimum Clock Low Period requirements of their respective specifications.
3. SMBus has a maximum requirement of 50 μs for Clock High Period. Operating frequencies lower than 40 kHz will be longer than 50 μs . I2C can support periods longer than 50 μs .

Table 4.16. SMBus Peripheral Timing Formulas (Master Mode)

Parameter	Symbol	Clocks
SMBus Operating Frequency	f_{SMB}	$f_{CSO} / 3$
Bus Free Time Between STOP and START Conditions	t_{BUF}	$2 / f_{CSO}$
Hold Time After (Repeated) START Condition	$t_{HD:STA}$	$1 / f_{CSO}$
Repeated START Condition Setup Time	$t_{SU:STA}$	$2 / f_{CSO}$
STOP Condition Setup Time	$t_{SU:STO}$	$2 / f_{CSO}$
Clock Low Period	t_{LOW}	$1 / f_{CSO}$
Clock High Period	t_{HIGH}	$2 / f_{CSO}$

Note:
1. f_{CSO} is the SMBus peripheral clock source overflow frequency.

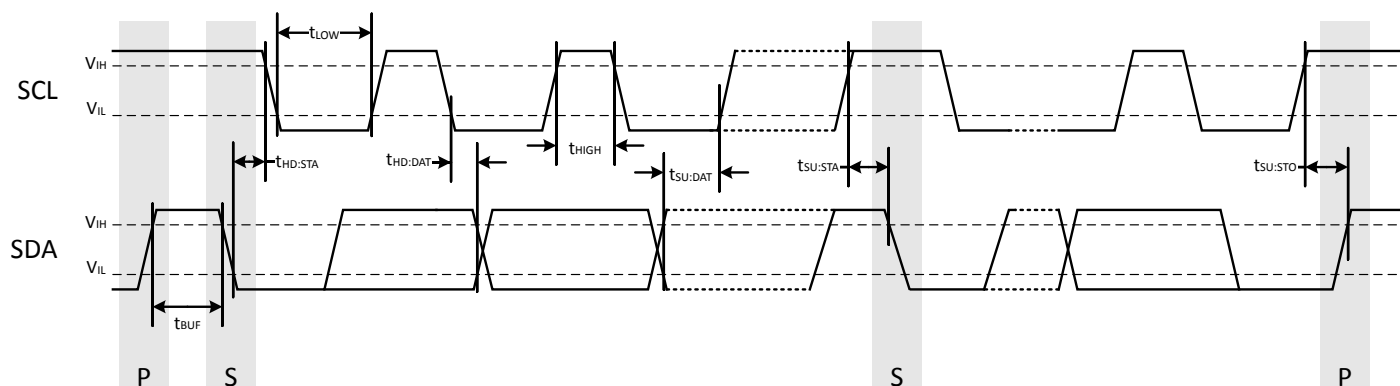

Figure 4.1. SMBus Peripheral Timing Diagram (Master Mode)

4.2 Thermal Conditions

Table 4.17. Thermal Conditions

Parameter	Symbol	Test Condition	Min	Typ	Max	Unit
Thermal Resistance	θ_{JA}	QFP48 Packages	—	60	—	°C/W
		QFP32 Packages	—	80	—	°C/W
		QFN32 Packages	—	28	—	°C/W

Note:
1. Thermal resistance assumes a multi-layer PCB with any exposed pad soldered to a PCB pad.

4.3 Absolute Maximum Ratings

Stresses above those listed in [Table 4.18 Absolute Maximum Ratings on page 23](#) may cause permanent damage to the device. This is a stress rating only and functional operation of the devices at those or any other conditions above those indicated in the operation listings of this specification is not implied. Exposure to maximum rating conditions for extended periods may affect device reliability. For more information on the available quality and reliability data, see the Quality and Reliability Monitor Report at <http://www.silabs.com/support/quality/pages/default.aspx>.

Table 4.18. Absolute Maximum Ratings

Parameter	Symbol	Test Condition	Min	Max	Unit
Ambient Temperature Under Bias	T_{BIAS}		-55	125	°C
Storage Temperature	T_{STG}		-65	150	°C
Voltage on VDD	V_{DD}		GND-0.3	4.2	V
Voltage on VREGIN	V_{REGIN}		GND-0.3	5.8	V
Voltage on I/O, RSTb, or VBUS pins	V_{IN}	$V_{DD} > 2.2\text{ V}$	GND-0.3	5.8	V
		$V_{DD} < 2.2\text{ V}$	GND-0.3	$V_{DD}+3.6$	V
Total Current Sunk into Supply Pin	I_{VDD}		—	500	mA
Total Current Sourced out of Ground Pin	I_{GND}		500	—	mA
Current Sourced or Sunk by any I/O Pin or RSTb	I_{IO}		-100	100	mA

Note:

1. Exposure to maximum rating conditions for extended periods may affect device reliability.

4.4 Typical Performance Curves

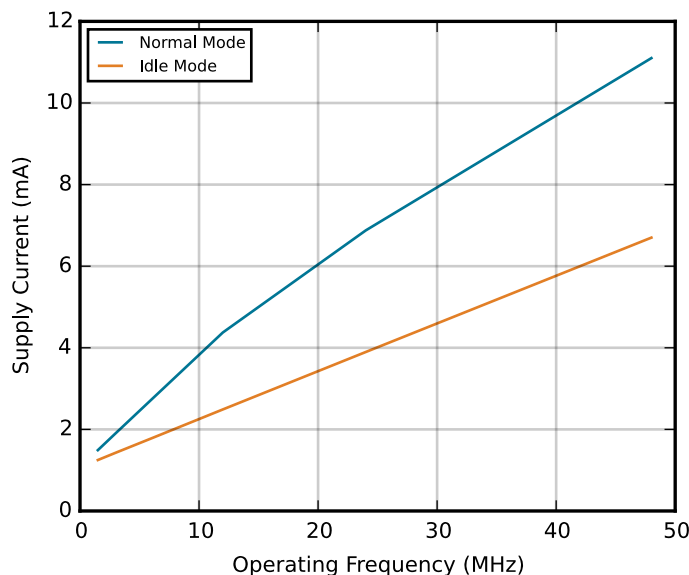

Figure 4.2. Typical Operating Supply Current using HFOSC0

5. Typical Connection Diagrams

5.1 Power

Figure 5.1 Connection Diagram with Voltage Regulator Used and USB Connected (Bus-Powered) on page 24 shows a typical connection diagram for the power pins of the EFM8UB2 devices when the internal regulator used and USB is connected (bus-powered). The VBUS signal is used to detect when USB is connected to a host device.

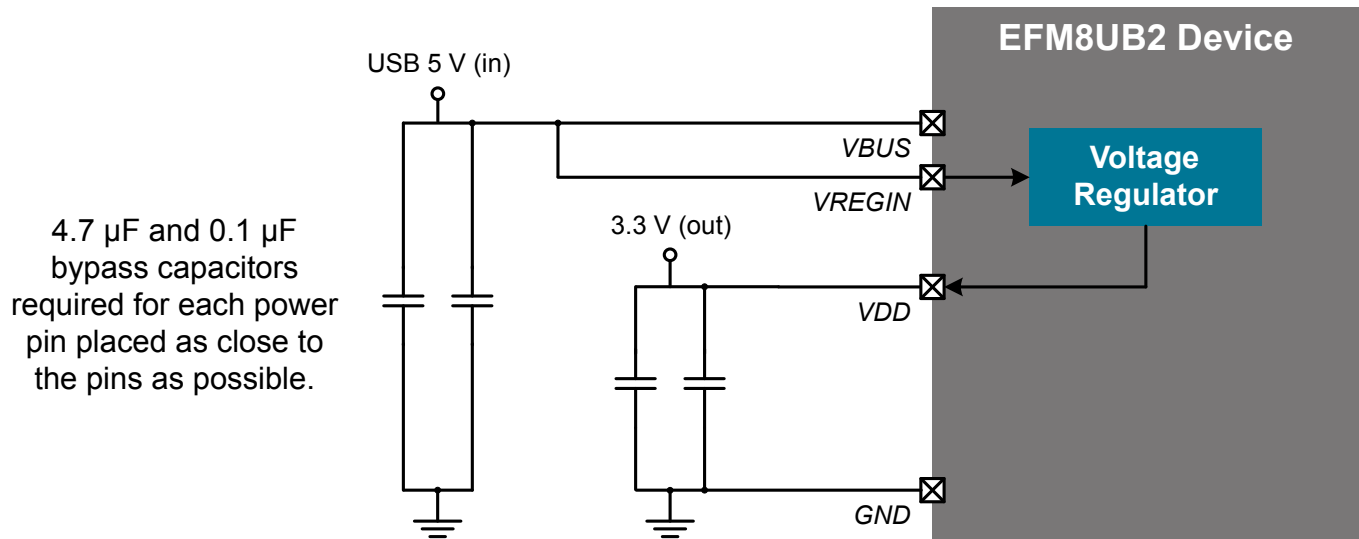

Figure 5.1. Connection Diagram with Voltage Regulator Used and USB Connected (Bus-Powered)

Figure 5.2 Connection Diagram with Voltage Regulator Used and USB Connected (Self-Powered) on page 25 shows a typical connection diagram for the power pins of the EFM8UB2 devices when the internal regulator used and USB is connected (self-powered). The VBUS signal is used to detect when USB is connected to a host device and is shown with a resistor divider. This resistor divider (or functionally-equivalent circuit) on VBUS is required to meet the absolute maximum voltage on VBUS specification for self-powered systems where VDD and VIO may be unpowered when VBUS is connected to 5 V.

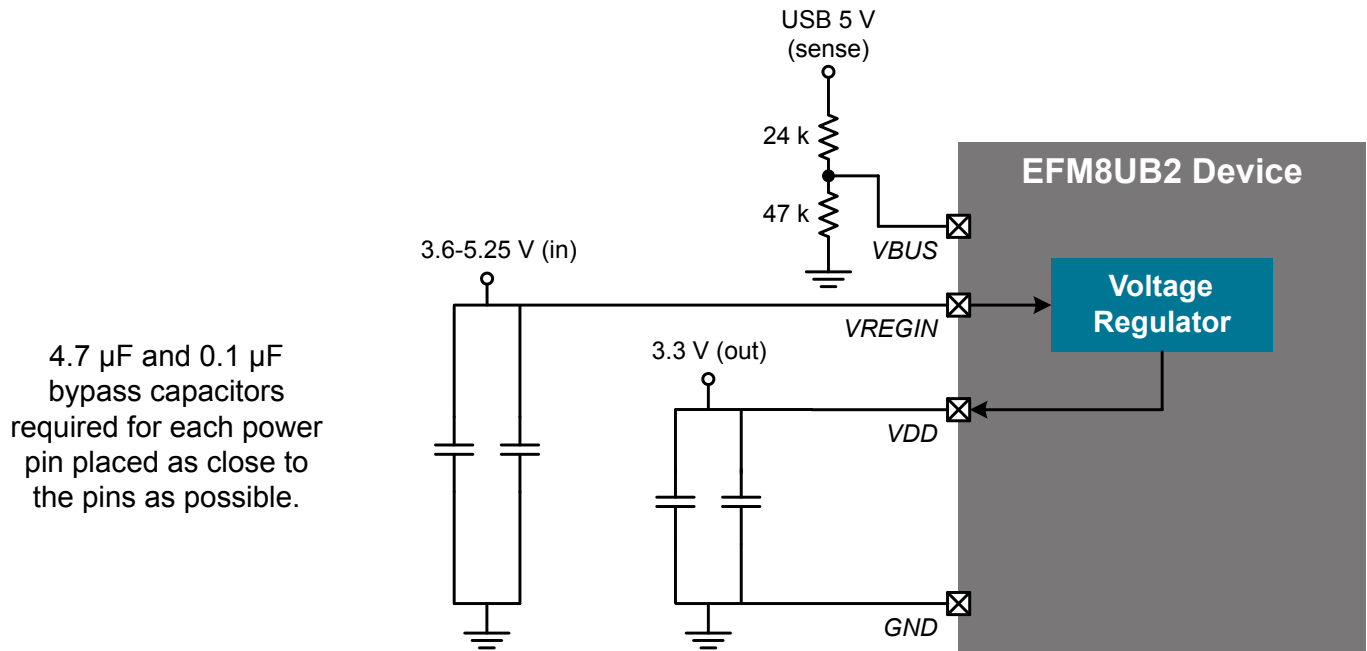

Figure 5.2. Connection Diagram with Voltage Regulator Used and USB Connected (Self-Powered)

The figure below shows a typical connection diagram for the power pins of the EFM8UB2 devices when the internal 5 V-to-3.3 V regulator is not used.

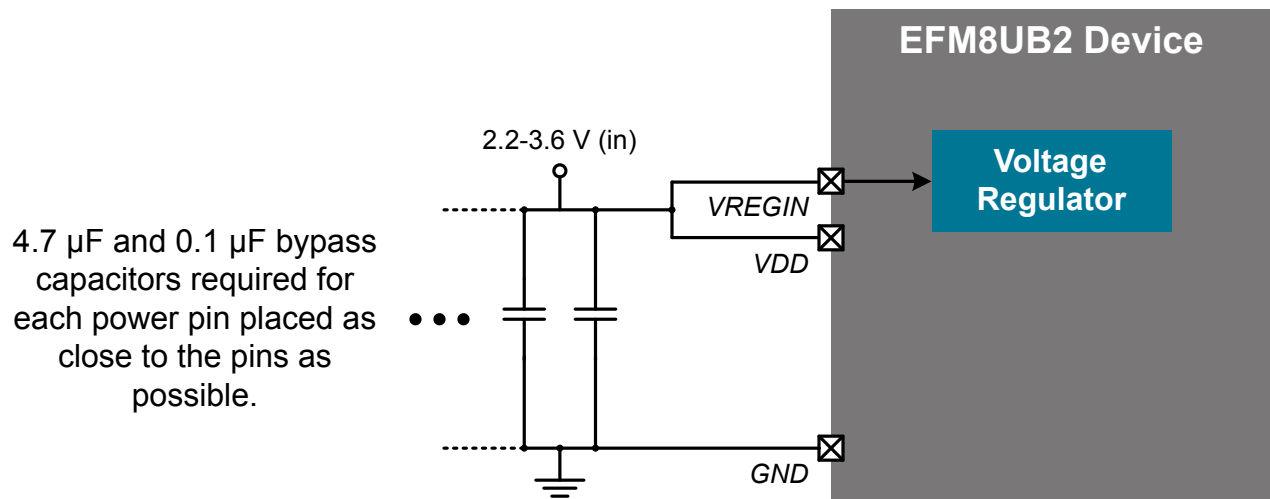

Figure 5.3. Connection Diagram with Voltage Regulator Not Used

5.2 USB

Figure 5.4 Connection Diagram for USB Pins on page 26 shows a typical connection diagram for the USB pins of the EFM8UB2 devices including ESD protection diodes on the USB pins.

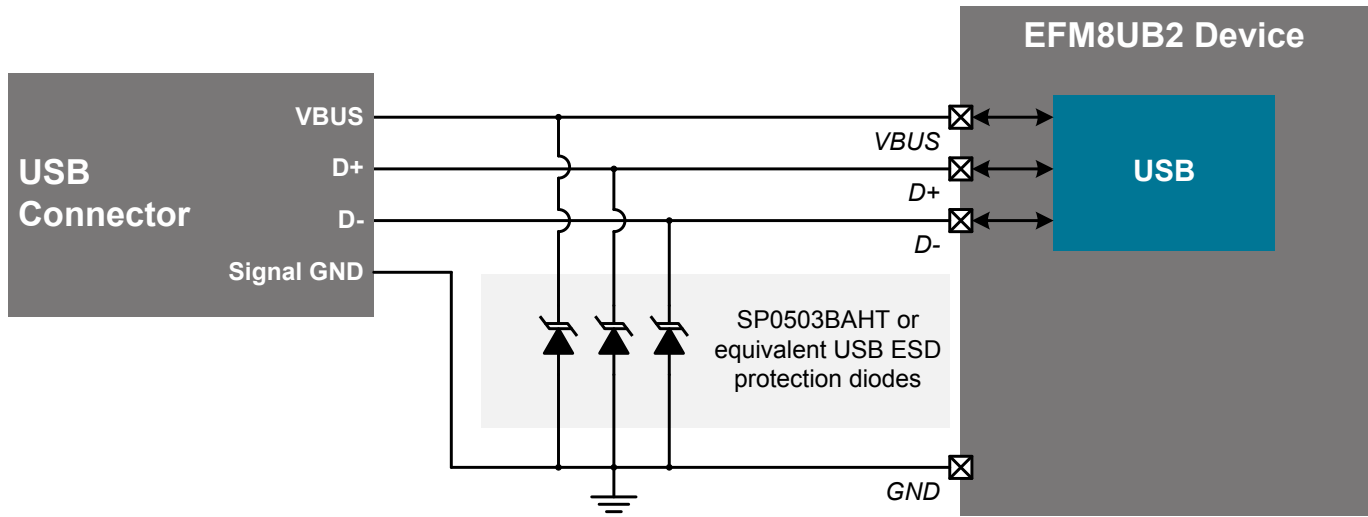

Figure 5.4. Connection Diagram for USB Pins

5.3 Voltage Reference (VREF)

Figure 5.5 Connection Diagram for Internal Voltage Reference on page 26 shows a typical connection diagram for the voltage reference (VREF) pin of the EFM8UB2 devices when using the internal voltage reference. When using an external voltage reference, consult the external reference data sheet for connection recommendations.

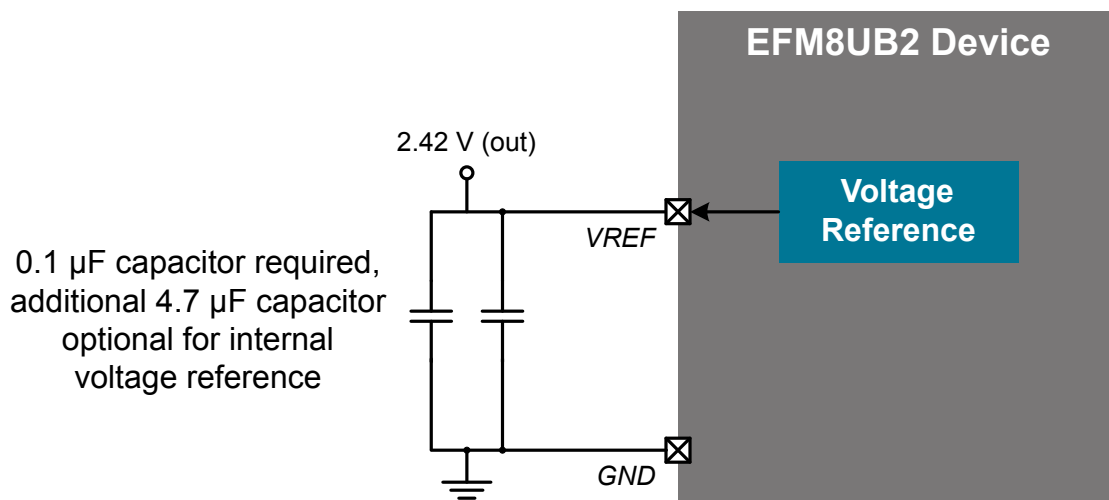
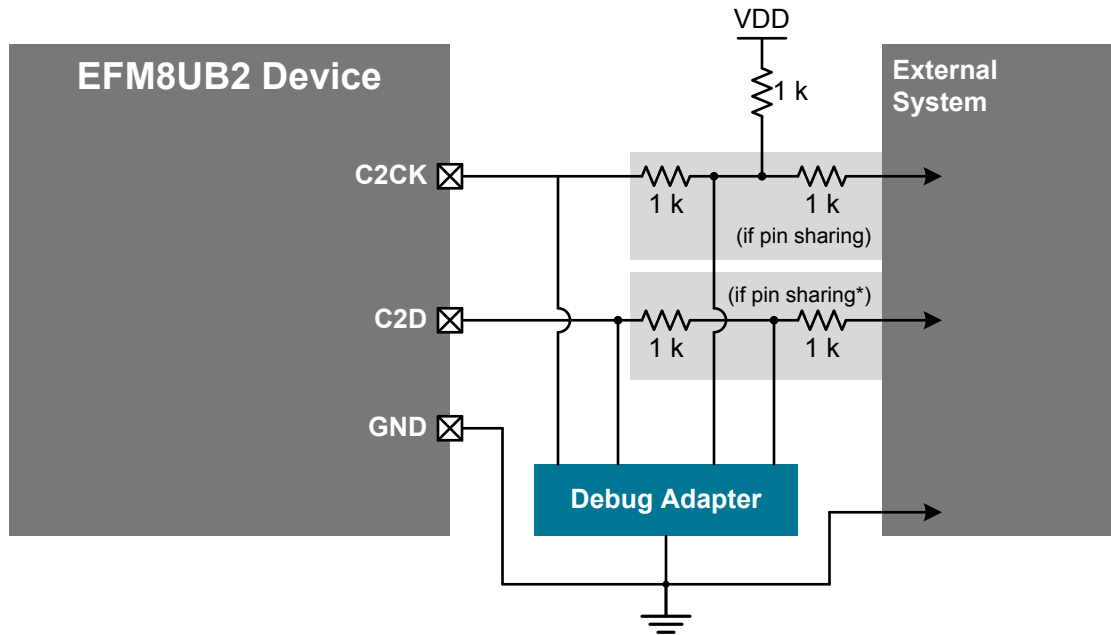

Figure 5.5. Connection Diagram for Internal Voltage Reference

5.4 Debug

The diagram below shows a typical connection diagram for the debug connections pins. The pin sharing resistors are only required if the functionality on the C2D (a GPIO pin for non QFP48 packages) and the C2CK (RSTb) is routed to external circuitry. For example, if the RSTb pin is connected to an external switch with debouncing filter or if the GPIO sharing with the C2D pin is connected to an external circuit, the pin sharing resistors and connections to the debug adapter must be placed on the hardware. Otherwise, these components and connections can be omitted.

For more information on debug connections, see the example schematics and information available in application note, "AN127: Pin Sharing Techniques for the C2 Interface." Application notes can be found on the Silicon Labs website (<http://www.silabs.com/8bit-app-notes>) or in Simplicity Studio.



***Note:** Not needed on QFP48 packages since C2D is not shared with a GPIO pin.

Figure 5.6. Debug Connection Diagram

5.5 Other Connections

Other components or connections may be required to meet the system-level requirements. Application note, "AN203: 8-bit MCU Printed Circuit Board Design Notes", contains detailed information on these connections. Application Notes can be accessed on the Silicon Labs website (www.silabs.com/8bit-appnotes).

6. Pin Definitions

6.1 EFM8UB2x-QFP48 Pin Definitions

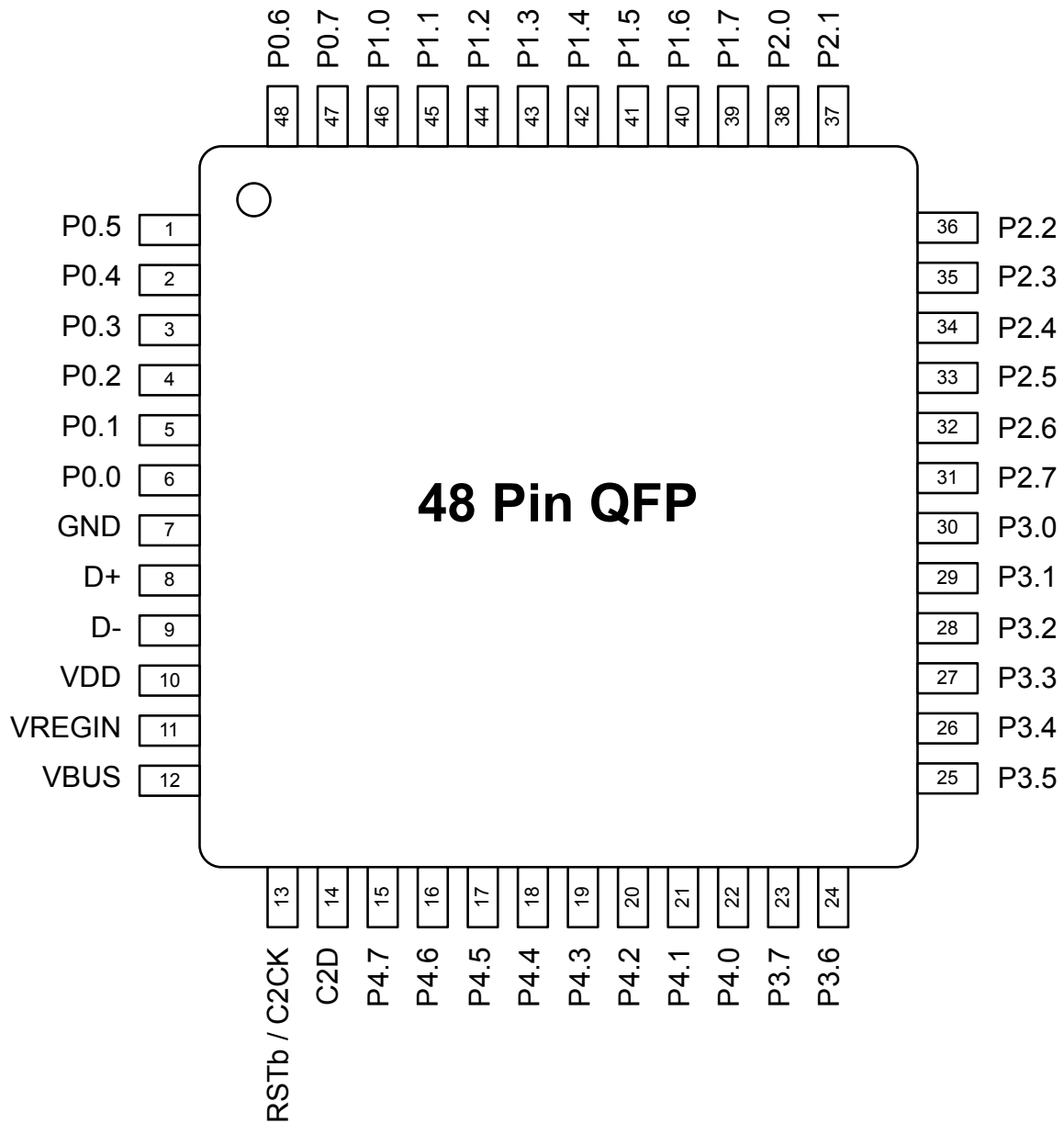

Figure 6.1. EFM8UB2x-QFP48 Pinout

Table 6.1. Pin Definitions for EFM8UB2x-QFP48

Pin Number	Pin Name	Description	Crossbar Capability	Additional Digital Functions	Analog Functions
1	P0.5	Multifunction I/O	Yes	UART0_RX INT0.5 INT1.5	
2	P0.4	Multifunction I/O	Yes	UART0_TX INT0.4 INT1.4	ADC0P.18 ADC0N.18 CMP0N.4
3	P0.3	Multifunction I/O	Yes	INT0.3 INT1.3	ADC0P.17 ADC0N.17 CMP0P.4
4	P0.2	Multifunction I/O	Yes	INT0.2 INT1.2	
5	P0.1	Multifunction I/O	Yes	INT0.1 INT1.1	
6	P0.0	Multifunction I/O	Yes	INT0.0 INT1.0	
7	GND	Ground			
8	D+	USB Data Positive			
9	D-	USB Data Negative			
10	VDD	Supply Power Input / 5V Regulator Output			
11	VREGIN	5V Regulator Input			
12	VBUS	USB VBUS Sense Input		VBUS	
13	RST / C2CK	Active-low Reset / C2 Debug Clock			
14	C2D	C2 Debug Data			
15	P4.7	Multifunction I/O		EMIF_D7 EMIF_AD7m	ADC0P.34 ADC0N.34
16	P4.6	Multifunction I/O		EMIF_D6 EMIF_AD6m	ADC0P.15 ADC0N.15 CMP1N.3
17	P4.5	Multifunction I/O		EMIF_D5 EMIF_AD5m	ADC0P.14 ADC0N.14 CMP1P.3

Pin Number	Pin Name	Description	Crossbar Capability	Additional Digital Functions	Analog Functions
18	P4.4	Multifunction I/O		EMIF_D4 EMIF_AD4m	ADC0P.13 ADC0N.13 CMP0N.3
19	P4.3	Multifunction I/O		EMIF_D3 EMIF_AD3m	ADC0P.12 ADC0N.12 CMP0P.3
20	P4.2	Multifunction I/O		EMIF_D2 EMIF_AD2m	ADC0P.33 ADC0N.33
21	P4.1	Multifunction I/O		EMIF_D1 EMIF_AD1m	ADC0P.32 ADC0N.32
22	P4.0	Multifunction I/O		EMIF_D0 EMIF_AD0m	ADC0P.11 ADC0N.11 CMP1N.2
23	P3.7	Multifunction I/O	Yes	EMIF_A7 EMIF_A15m	ADC0P.10 ADC0N.10 CMP1P.2
24	P3.6	Multifunction I/O	Yes	EMIF_A6 EMIF_A14m	ADC0P.29 ADC0N.29
25	P3.5	Multifunction I/O	Yes	EMIF_A5 EMIF_A13m	ADC0P.9 ADC0N.9 CMP0N.2
26	P3.4	Multifunction I/O	Yes	EMIF_A4 EMIF_A12m	ADC0P.8 ADC0N.8 CMP0P.2
27	P3.3	Multifunction I/O	Yes	EMIF_A3 EMIF_A11m	ADC0P.28 ADC0N.28
28	P3.2	Multifunction I/O	Yes	EMIF_A2 EMIF_A10m	ADC0P.27 ADC0N.27
29	P3.1	Multifunction I/O	Yes	EMIF_A1 EMIF_A9m	ADC0P.7 ADC0N.7 CMP1N.1
30	P3.0	Multifunction I/O	Yes	EMIF_A0 EMIF_A8m	ADC0P.6 ADC0N.6 CMP1P.1
31	P2.7	Multifunction I/O	Yes	EMIF_A15	ADC0P.26 ADC0N.26

Pin Number	Pin Name	Description	Crossbar Capability	Additional Digital Functions	Analog Functions
32	P2.6	Multifunction I/O	Yes	EMIF_A14	ADC0P.5 ADC0N.5 CMP0N.1
33	P2.5	Multifunction I/O	Yes	EMIF_A13	ADC0P.4 ADC0N.4 CMP0P.1
34	P2.4	Multifunction I/O	Yes	EMIF_A12	ADC0P.25 ADC0N.25
35	P2.3	Multifunction I/O	Yes	EMIF_A11	ADC0P.3 ADC0N.3 CMP1N.0
36	P2.2	Multifunction I/O	Yes	EMIF_A10	ADC0P.2 ADC0N.2 CMP1P.0
37	P2.1	Multifunction I/O	Yes	EMIF_A9	ADC0P.1 ADC0N.1 CMP0N.0
38	P2.0	Multifunction I/O	Yes	EMIF_A8	ADC0P.0 ADC0N.0 CMP0P.0
39	P1.7	Multifunction I/O	Yes	EMIF_WRb	ADC0P.24 ADC0N.24
40	P1.6	Multifunction I/O	Yes	EMIF_RDb	ADC0P.23 ADC0N.23
41	P1.5	Multifunction I/O	Yes		VREF
42	P1.4	Multifunction I/O	Yes	CNVSTR	
43	P1.3	Multifunction I/O	Yes	EMIF_ALEm	ADC0P.22 ADC0N.22
44	P1.2	Multifunction I/O	Yes		ADC0P.20 ADC0N.20 CMP1N.4
45	P1.1	Multifunction I/O	Yes		ADC0P.19 ADC0N.19 CMP1P.4
46	P1.0	Multifunction I/O	Yes		ADC0P.21 ADC0N.21

Pin Number	Pin Name	Description	Crossbar Capability	Additional Digital Functions	Analog Functions
47	P0.7	Multifunction I/O	Yes	XTAL2 EXTCLK INT0.7 INT1.7	
48	P0.6	Multifunction I/O	Yes	XTAL1 INT0.6 INT1.6	

6.2 EFM8UB2x-QFP32 Pin Definitions

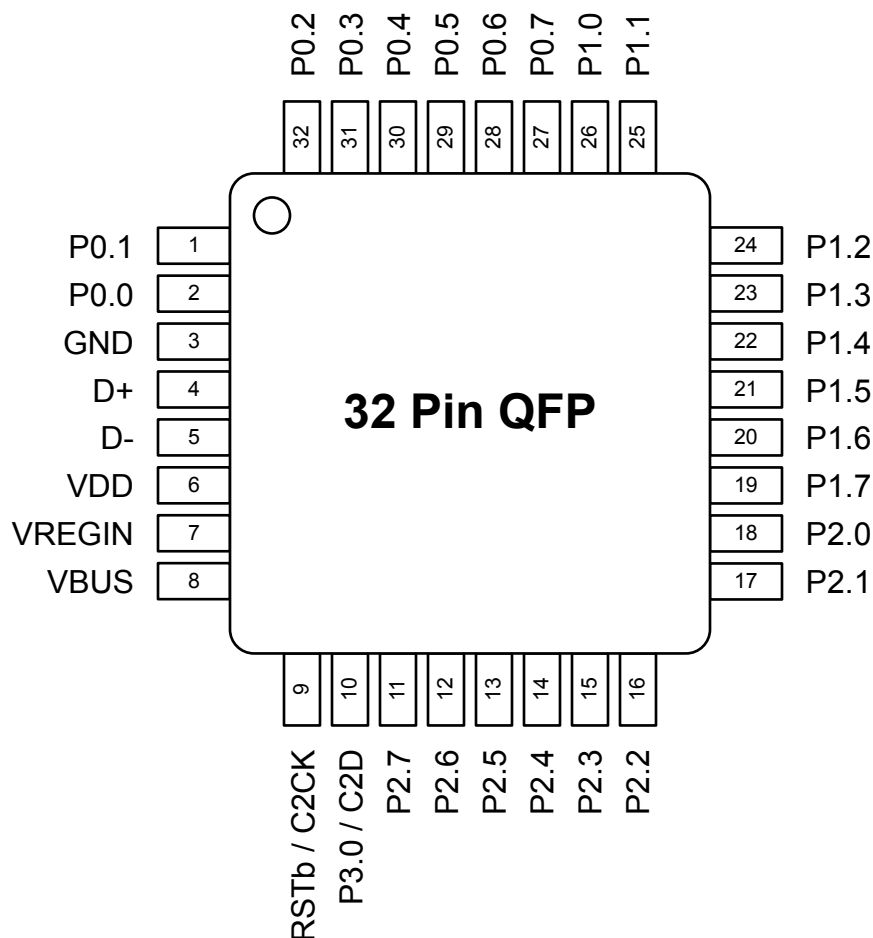

Figure 6.2. EFM8UB2x-QFP32 Pinout

Table 6.2. Pin Definitions for EFM8UB2x-QFP32

Pin Number	Pin Name	Description	Crossbar Capability	Additional Digital Functions	Analog Functions
1	P0.1	Multifunction I/O	Yes	INT0.1 INT1.1	ADC0P.18 ADC0N.18 CMP0N.4
2	P0.0	Multifunction I/O	Yes	INT0.0 INT1.0	ADC0P.17 ADC0N.17 CMP0P.4
3	GND	Ground			
4	D+	USB Data Positive			

Pin Number	Pin Name	Description	Crossbar Capability	Additional Digital Functions	Analog Functions
5	D-	USB Data Negative			
6	VDD	Supply Power Input / 5V Regulator Output			
7	VREGIN	5V Regulator Input			
8	VBUS	USB VBUS Sense Input		VBUS	
9	RST / C2CK	Active-low Reset / C2 Debug Clock			
10	P3.0 / C2D	Multifunction I/O / C2 Debug Data	Yes		ADC0P.16 ADC0N.16
11	P2.7	Multifunction I/O	Yes		ADC0P.15 ADC0N.15
12	P2.6	Multifunction I/O	Yes		ADC0P.14 ADC0N.14
13	P2.5	Multifunction I/O	Yes		ADC0P.13 ADC0N.13 CMP0N.3
14	P2.4	Multifunction I/O	Yes		ADC0P.12 ADC0N.12 CMP0P.3
15	P2.3	Multifunction I/O	Yes		ADC0P.11 ADC0N.11 CMP1N.2
16	P2.2	Multifunction I/O	Yes		ADC0P.10 ADC0N.10 CMP1P.2
17	P2.1	Multifunction I/O	Yes		ADC0P.9 ADC0N.9 CMP0N.2
18	P2.0	Multifunction I/O	Yes		ADC0P.8 ADC0N.8 CMP0P.2
19	P1.7	Multifunction I/O	Yes		ADC0P.7 ADC0N.7 CMP1N.1

Pin Number	Pin Name	Description	Crossbar Capability	Additional Digital Functions	Analog Functions
20	P1.6	Multifunction I/O	Yes		ADC0P.6 ADC0N.6 CMP1P.1
21	P1.5	Multifunction I/O	Yes		ADC0P.5 ADC0N.5 CMP0N.1
22	P1.4	Multifunction I/O	Yes		ADC0P.4 ADC0N.4 CMP0P.1
23	P1.3	Multifunction I/O	Yes		ADC0P.3 ADC0N.3 CMP1N.0
24	P1.2	Multifunction I/O	Yes		ADC0P.2 ADC0N.2 CMP1P.0
25	P1.1	Multifunction I/O	Yes		ADC0P.1 ADC0N.1 CMP0N.0
26	P1.0	Multifunction I/O	Yes		ADC0P.0 ADC0N.0 CMP0P.0
27	P0.7	Multifunction I/O	Yes	INT0.7 INT1.7	VREF
28	P0.6	Multifunction I/O	Yes	CNVSTR INT0.6 INT1.6	
29	P0.5	Multifunction I/O	Yes	INT0.5 INT1.5 UART0_RX	ADC0P.20 ADC0N.20 CMP1N.4
30	P0.4	Multifunction I/O	Yes	INT0.4 INT1.4 UART0_TX	ADC0P.19 ADC0N.19 CMP1P.4
31	P0.3	Multifunction I/O	Yes	EXTCLK INT0.3 INT1.3	

Pin Number	Pin Name	Description	Crossbar Capability	Additional Digital Functions	Analog Functions
32	P0.2	Multifunction I/O	Yes	INT0.2 INT1.2	

Note: XTAL1 and XTAL2 are not available on this package. EXTCLK is still available on P0.3.

6.3 EFM8UB2x-QFN32 Pin Definitions

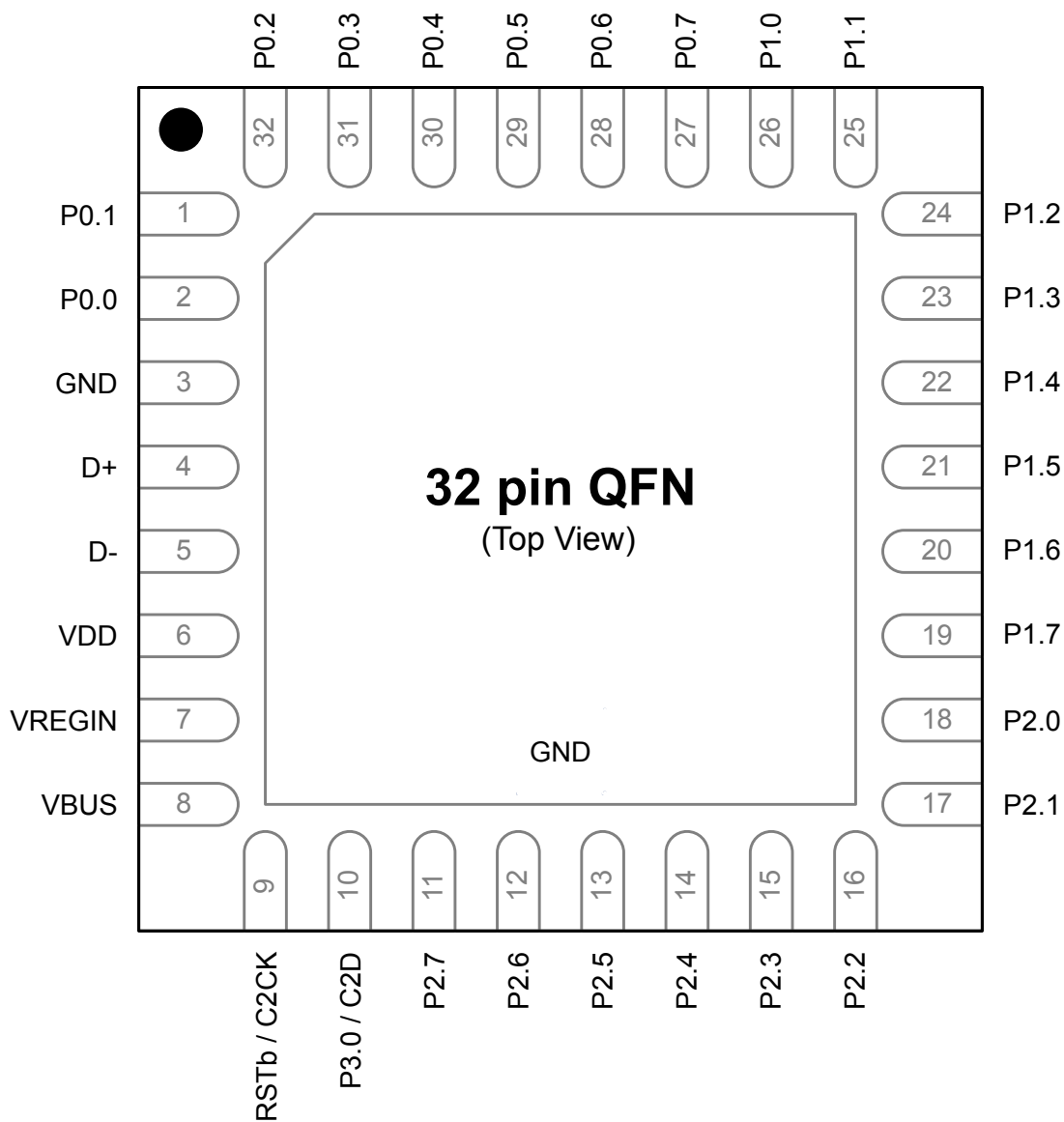

Figure 6.3. EFM8UB2x-QFN32 Pinout

Table 6.3. Pin Definitions for EFM8UB2x-QFN32

Pin Number	Pin Name	Description	Crossbar Capability	Additional Digital Functions	Analog Functions
1	P0.1	Multifunction I/O	Yes	INT0.1 INT1.1	ADC0P.18 ADC0N.18 CMP0N.4

Pin Number	Pin Name	Description	Crossbar Capability	Additional Digital Functions	Analog Functions
2	P0.0	Multifunction I/O	Yes	INT0.0 INT1.0	ADC0P.17 ADC0N.17 CMP0P.4
3	GND	Ground			
4	D+	USB Data Positive			
5	D-	USB Data Negative			
6	VDD	Supply Power Input / 5V Regulator Output			
7	VREGIN	5V Regulator Input			
8	VBUS	USB VBUS Sense In- put		VBUS	
9	RST / C2CK	Active-low Reset / C2 Debug Clock			
10	P3.0 / C2D	Multifunction I/O / C2 Debug Data	Yes		ADC0P.16 ADC0N.16
11	P2.7	Multifunction I/O	Yes		ADC0P.15 ADC0N.15
12	P2.6	Multifunction I/O	Yes		ADC0P.14 ADC0N.14
13	P2.5	Multifunction I/O	Yes		ADC0P.13 ADC0N.13 CMP0N.3
14	P2.4	Multifunction I/O	Yes		ADC0P.12 ADC0N.12 CMP0P.3
15	P2.3	Multifunction I/O	Yes		ADC0P.11 ADC0N.11 CMP1N.2
16	P2.2	Multifunction I/O	Yes		ADC0P.10 ADC0N.10 CMP1P.2
17	P2.1	Multifunction I/O	Yes		ADC0P.9 ADC0N.9 CMP0N.2

Pin Number	Pin Name	Description	Crossbar Capability	Additional Digital Functions	Analog Functions
18	P2.0	Multifunction I/O	Yes		ADC0P.8 ADC0N.8 CMP0P.2
19	P1.7	Multifunction I/O	Yes		ADC0P.7 ADC0N.7 CMP1N.1
20	P1.6	Multifunction I/O	Yes		ADC0P.6 ADC0N.6 CMP1P.1
21	P1.5	Multifunction I/O	Yes		ADC0P.5 ADC0N.5 CMP0N.1
22	P1.4	Multifunction I/O	Yes		ADC0P.4 ADC0N.4 CMP0P.1
23	P1.3	Multifunction I/O	Yes		ADC0P.3 ADC0N.3 CMP1N.0
24	P1.2	Multifunction I/O	Yes		ADC0P.2 ADC0N.2 CMP1P.0
25	P1.1	Multifunction I/O	Yes		ADC0P.1 ADC0N.1 CMP0N.0
26	P1.0	Multifunction I/O	Yes		ADC0P.0 ADC0N.0 CMP0P.0
27	P0.7	Multifunction I/O	Yes	INT0.7 INT1.7	VREF
28	P0.6	Multifunction I/O	Yes	CNVSTR INT0.6 INT1.6	
29	P0.5	Multifunction I/O	Yes	INT0.5 INT1.5 UART0_RX	ADC0P.20 ADC0N.20 CMP1N.4

Pin Number	Pin Name	Description	Crossbar Capability	Additional Digital Functions	Analog Functions
30	P0.4	Multifunction I/O	Yes	INT0.4 INT1.4 UART0_TX	ADC0P.19 ADC0N.19 CMP1P.4
31	P0.3	Multifunction I/O	Yes	EXTCLK INT0.3 INT1.3	
32	P0.2	Multifunction I/O	Yes	INT0.2 INT1.2	
Center	GND	Ground			

Note: XTAL1 and XTAL2 are not available on this package. EXTCLK is still available on P0.3.

7. QFP48 Package Specifications

7.1 QFP48 Package Dimensions

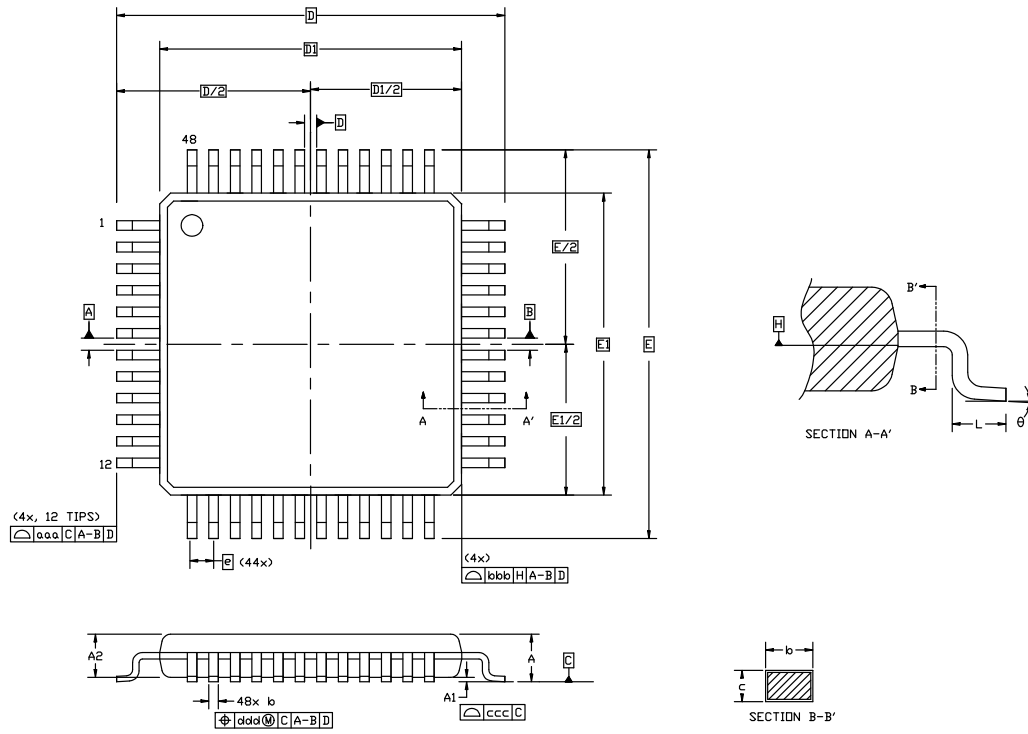

Figure 7.1. QFP48 Package Drawing

Table 7.1. QFP48 Package Dimensions

Dimension	Min	Typ	Max
A	—	—	1.20
A1	0.05	—	0.15
A2	0.95	1.00	1.05
b	0.17	0.22	0.27
D	9.00 BSC		
D1	7.00 BSC		
e	0.50 BSC		
E	9.00 BSC		
E1	7.00 BSC		
L	0.45	0.60	0.75
aaa	0.20		
bbb	0.20		

Dimension	Min	Typ	Max
ccc		0.08	
ddd		0.08	
theta	0°	3.5°	7°

Note:

1. All dimensions shown are in millimeters (mm) unless otherwise noted.
2. Dimensioning and Tolerancing per ANSI Y14.5M-1994.
3. This drawing conforms to JEDEC outline MS-026, variation ABC.
4. Recommended card reflow profile is per the JEDEC/IPC J-STD-020C specification for Small Body Components.

7.2 QFP48 PCB Land Pattern

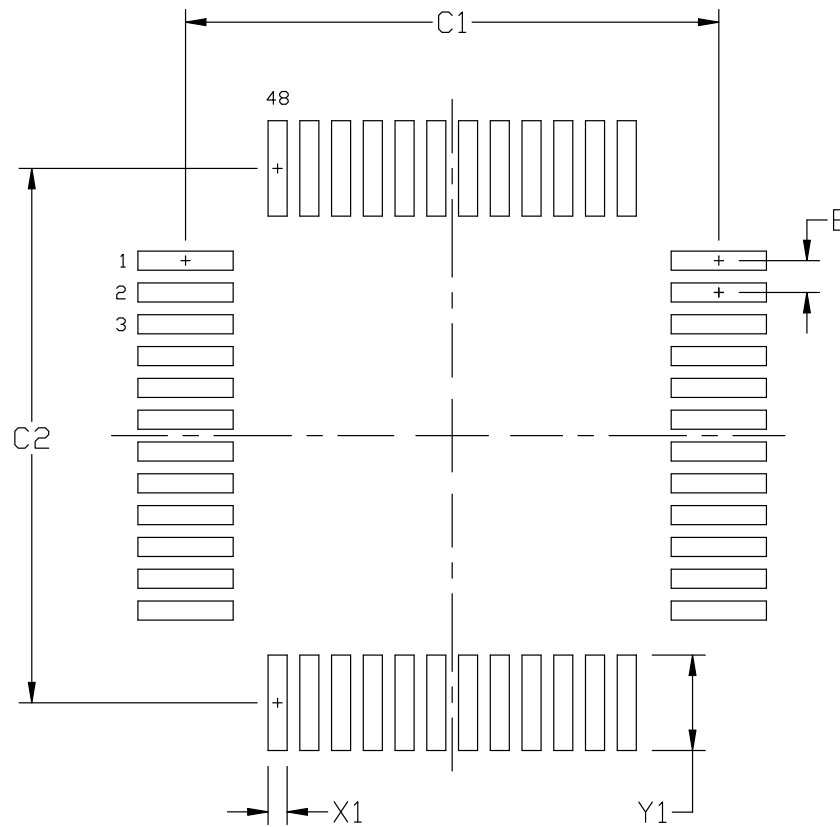

Figure 7.2. QFP48 PCB Land Pattern Drawing

Table 7.2. QFP48 PCB Land Pattern Dimensions

Dimension	Min	Max
C1	8.30	8.40
C2	8.30	8.40
E	0.50 BSC	
X1	0.20	0.30
Y1	1.40	1.50

Dimension	Min	Max
<p>Note:</p> <ol style="list-style-type: none"> 1. All dimensions shown are in millimeters (mm) unless otherwise noted. 2. This Land Pattern Design is based on the IPC-7351 guidelines. 3. All metal pads are to be non-solder mask defined (NSMD). Clearance between the solder mask and the metal pad is to be 60 µm minimum, all the way around the pad. 4. A stainless steel, laser-cut and electro-polished stencil with trapezoidal walls should be used to assure good solder paste release. 5. The stencil thickness should be 0.125 mm (5 mils). 6. The ratio of stencil aperture to land pad size should be 1:1 for all perimeter pads. 7. A No-Clean, Type-3 solder paste is recommended. 8. The recommended card reflow profile is per the JEDEC/IPC J-STD-020C specification for Small Body Components. 		

7.3 QFP48 Package Marking

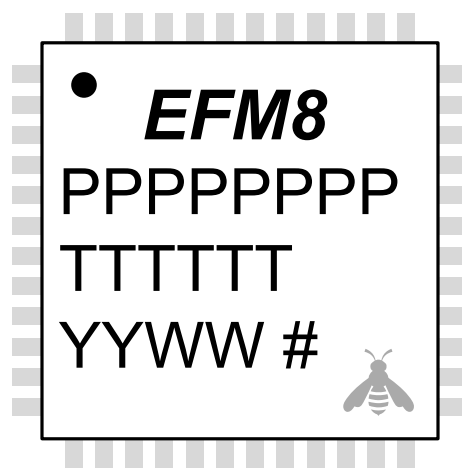

Figure 7.3. QFP48 Package Marking

The package marking consists of:

- P P P P P P P P – The part number designation.
- T T T T T T – A trace or manufacturing code.
- Y Y – The last 2 digits of the assembly year.
- W W – The 2-digit workweek when the device was assembled.
- # – The device revision (A, B, etc.).

8. QFP32 Package Specifications

8.1 QFP32 Package Dimensions

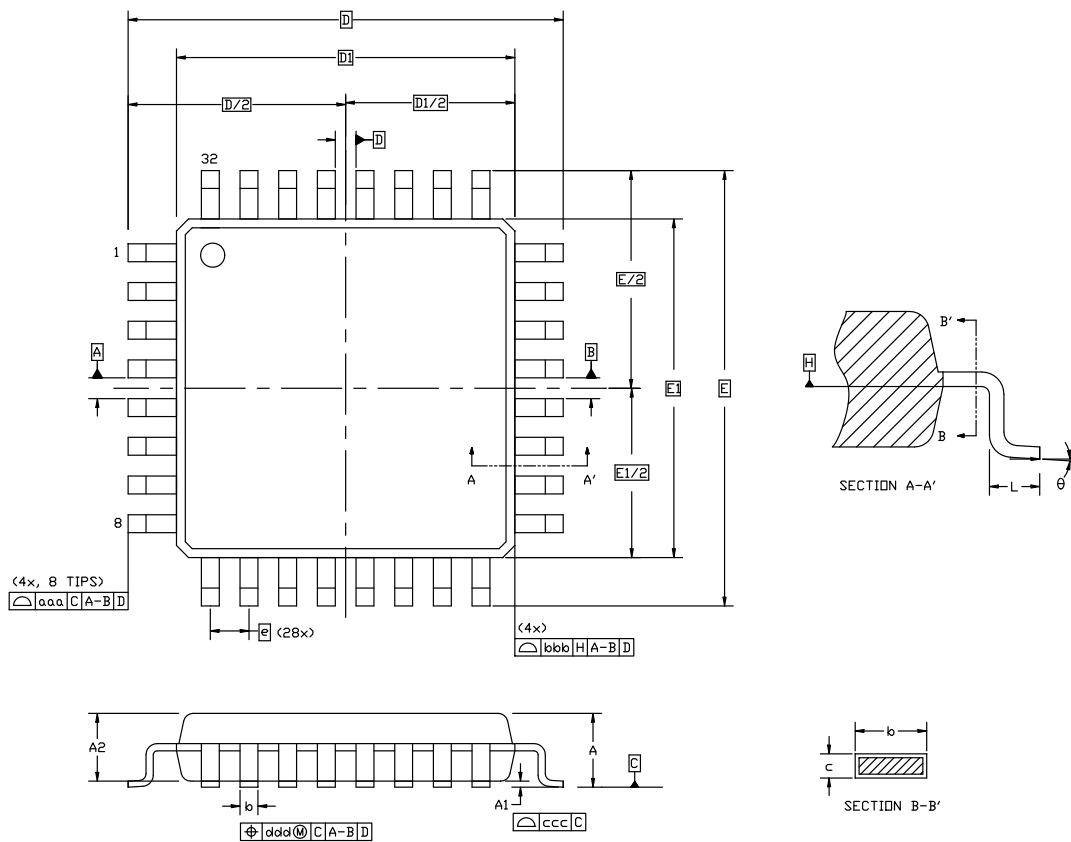

Figure 8.1. QFP32 Package Drawing

Table 8.1. QFP32 Package Dimensions

Dimension	Min	Typ	Max
A	—	—	1.60
A1	0.05	—	0.15
A2	1.35	1.40	1.45
b	0.30	0.37	0.45
D	9.00 BSC		
D1	7.00 BSC		
e	0.80 BSC		
E	9.00 BSC		
E1	7.00 BSC		
L	0.45	0.60	0.75
aaa	0.20		

Dimension	Min	Typ	Max
bbb		0.20	
ccc		0.10	
ddd		0.20	
theta	0°	3.5°	7°

Note:

1. All dimensions shown are in millimeters (mm) unless otherwise noted.
2. Dimensioning and Tolerancing per ANSI Y14.5M-1994.
3. This drawing conforms to JEDEC outline MS-026, variation BBA.
4. Recommended card reflow profile is per the JEDEC/IPC J-STD-020C specification for Small Body Components.

8.2 QFP32 PCB Land Pattern

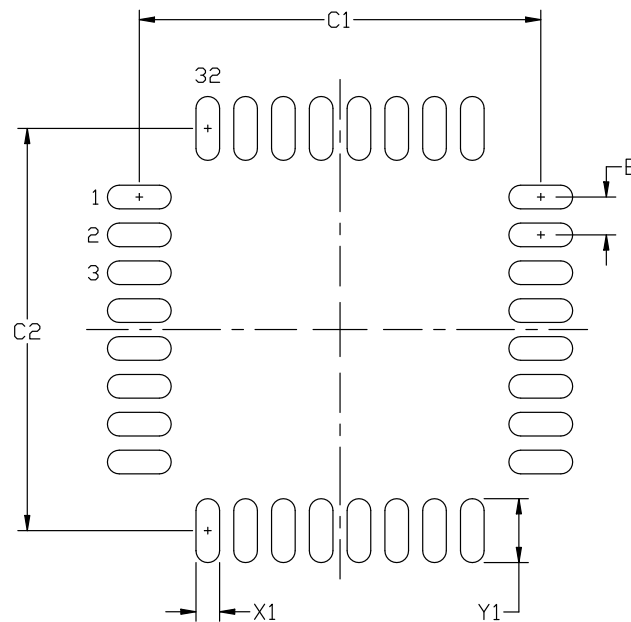

Figure 8.2. QFP32 PCB Land Pattern Drawing

Table 8.2. QFP32 PCB Land Pattern Dimensions

Dimension	Min	Max
C1	8.40	8.50
C2	8.40	8.50
E	0.80 BSC	
X1	0.40	0.50
Y1	1.25	1.35

Note:

1. All dimensions shown are in millimeters (mm) unless otherwise noted.
2. This Land Pattern Design is based on the IPC-7351 guidelines.
3. All metal pads are to be non-solder mask defined (NSMD). Clearance between the solder mask and the metal pad is to be 60 μm minimum, all the way around the pad.
4. A stainless steel, laser-cut and electro-polished stencil with trapezoidal walls should be used to assure good solder paste release.
5. The stencil thickness should be 0.125 mm (5 mils).
6. The ratio of stencil aperture to land pad size should be 1:1 for all perimeter pads.
7. A No-Clean, Type-3 solder paste is recommended.
8. The recommended card reflow profile is per the JEDEC/IPC J-STD-020C specification for Small Body Components.

8.3 QFP32 Package Marking

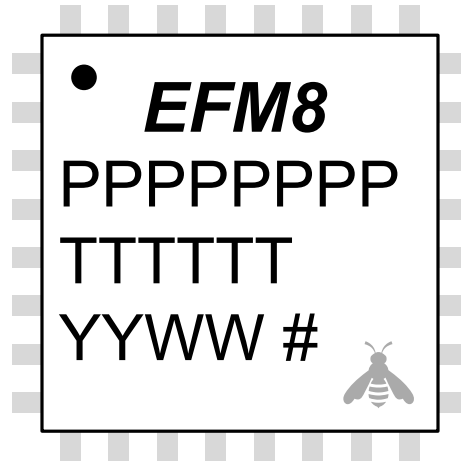

Figure 8.3. QFP32 Package Marking

The package marking consists of:

- P P P P P P P P – The part number designation.
- T T T T T T – A trace or manufacturing code.
- Y Y – The last 2 digits of the assembly year.
- W W – The 2-digit workweek when the device was assembled.
- # – The device revision (A, B, etc.).

9. QFN32 Package Specifications

9.1 QFN32 Package Dimensions

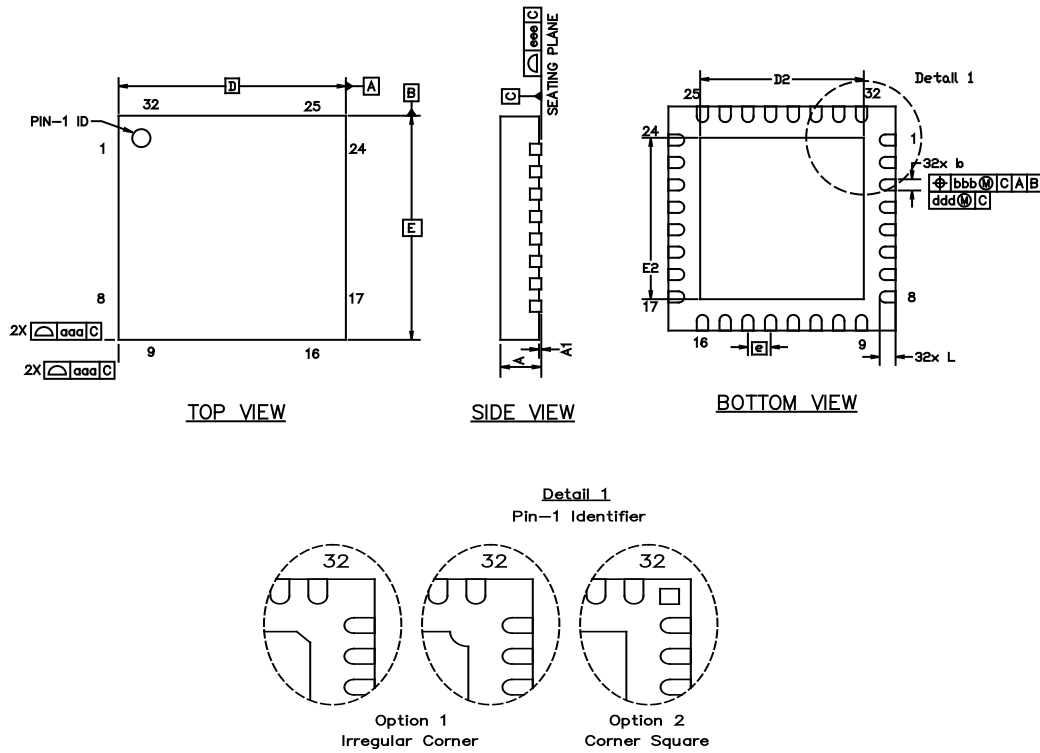

Figure 9.1. QFN32 Package Drawing

Table 9.1. QFN32 Package Dimensions

Dimension	Min	Typ	Max
A	0.80	0.85	0.90
A1	0.00	0.02	0.05
b	0.18	0.25	0.30
D	5.00 BSC		
D2	3.20	3.30	3.40
e	0.50 BSC		
E	5.00 BSC		
E2	3.20	3.30	3.40
L	0.35	0.40	0.45
aaa	—	—	0.10
bbb	—	—	0.10

Dimension	Min	Typ	Max
ddd	—	—	0.05
eee	—	—	0.08

Note:

1. All dimensions shown are in millimeters (mm) unless otherwise noted.
2. Dimensioning and Tolerancing per ANSI Y14.5M-1994.
3. This drawing conforms to JEDEC Solid State Outline MO-220, variation VHHD except for custom features D2, E2, and L which are toleranced per supplier designation.
4. Recommended card reflow profile is per the JEDEC/IPC J-STD-020C specification for Small Body Components.

9.2 QFN32 PCB Land Pattern

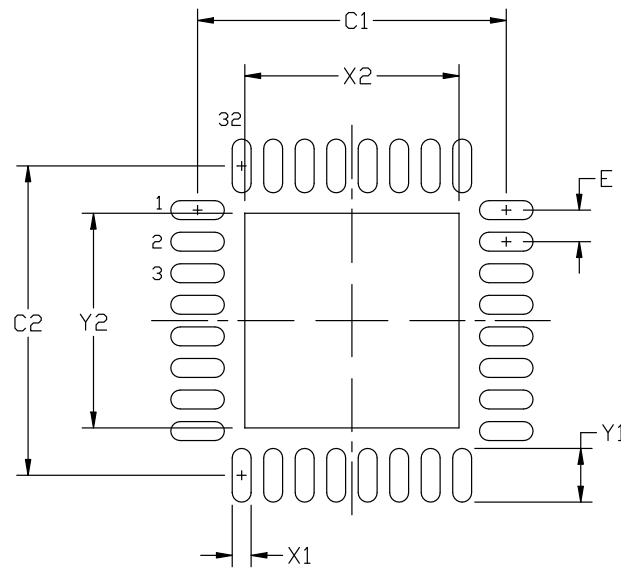

Figure 9.2. QFN32 PCB Land Pattern Drawing

Table 9.2. QFN32 PCB Land Pattern Dimensions

Dimension	Min	Max
C1	4.80	4.90
C2	4.80	4.90
E	0.50 BSC	
X1	0.20	0.30
X2	3.20	3.40
Y1	0.75	0.85
Y2	3.20	3.40

Note:

1. All dimensions shown are in millimeters (mm) unless otherwise noted.
2. This Land Pattern Design is based on the IPC-7351 guidelines.
3. All metal pads are to be non-solder mask defined (NSMD). Clearance between the solder mask and the metal pad is to be 60 μm minimum, all the way around the pad.
4. A stainless steel, laser-cut and electro-polished stencil with trapezoidal walls should be used to assure good solder paste release.
5. The stencil thickness should be 0.125 mm (5 mils).
6. The ratio of stencil aperture to land pad size should be 1:1 for all perimeter pads.
7. A 3 x 3 array of 1.0 mm x 1.0 mm openings on a 1.2 mm pitch should be used for the center pad.
8. A No-Clean, Type-3 solder paste is recommended.
9. The recommended card reflow profile is per the JEDEC/IPC J-STD-020C specification for Small Body Components.

9.3 QFN32 Package Marking



Figure 9.3. QFN32 Package Marking

The package marking consists of:

- P P P P P P P P – The part number designation.
- T T T T T T – A trace or manufacturing code.
- Y Y – The last 2 digits of the assembly year.
- W W – The 2-digit workweek when the device was assembled.
- # – The device revision (A, B, etc.).

10. Revision History

10.1 Revision 1.3

Updated ordering part numbers to revision B.

Added Power-On Reset Threshold and Reset Delay from POR specifications to [4.1.3 Reset and Supply Monitor](#).

Added CRC Calculation Time specification to [4.1.4 Flash Memory](#).

Added VBUS Detection Input High Voltage and VBUS Detection Input Low Voltage specifications to [Table 4.14 USB Transceiver on page 20](#).

Added specifications for [4.1.15 SMBus](#).

Added [5.4 Debug](#).

Added information about bootloader implementation and bootloader pinout to [3.10 Bootloader](#).

Added notes to [Table 6.3 Pin Definitions for EFM8UB2x-QFN32 on page 37](#) and [Table 6.2 Pin Definitions for EFM8UB2x-QFP32 on page 33](#) to clarify that XTAL1 and XTAL2 are not available on the 32-pin packages.

Updated [Figure 5.1 Connection Diagram with Voltage Regulator Used and USB Connected \(Bus-Powered\) on page 24](#) and [Figure 5.2 Connection Diagram with Voltage Regulator Used and USB Connected \(Self-Powered\) on page 25](#) to recommend 4.7 μ F capacitors instead of 1.0 μ F capacitors.

Added text and [Figure 5.3 Connection Diagram with Voltage Regulator Not Used on page 25](#) to demonstrate the proper connections when the regulator is not used.

Added reference to the Reference Manual in [3.1 Introduction](#).

10.2 Revision 1.2

Updated the VDD Ramp Time specification in [Table 4.3 Reset and Supply Monitor on page 13](#) to a maximum of 1 ms.

10.3 Revision 1.1

Initial release.

Table of Contents

1. Feature List	1
2. Ordering Information	2
3. System Overview	3
3.1 Introduction	3
3.2 Power	4
3.3 I/O	4
3.4 Clocking	4
3.5 Counters/Timers and PWM	5
3.6 Communications and Other Digital Peripherals	6
3.7 Analog	7
3.8 Reset Sources	8
3.9 Debugging	8
3.10 Bootloader	9
4. Electrical Specifications	11
4.1 Electrical Characteristics	11
4.1.1 Recommended Operating Conditions	11
4.1.2 Power Consumption	12
4.1.3 Reset and Supply Monitor	13
4.1.4 Flash Memory	13
4.1.5 Internal Oscillators	14
4.1.6 Crystal Oscillator	14
4.1.7 External Clock Input	14
4.1.8 ADC	15
4.1.9 Voltage Reference	16
4.1.10 Temperature Sensor	16
4.1.11 5 V Voltage Regulator	17
4.1.12 Comparators	18
4.1.13 Port I/O	19
4.1.14 USB Transceiver	20
4.1.15 SMBus	21
4.2 Thermal Conditions	22
4.3 Absolute Maximum Ratings	23
4.4 Typical Performance Curves	23
5. Typical Connection Diagrams	24
5.1 Power	24
5.2 USB	26
5.3 Voltage Reference (VREF)	26
5.4 Debug	27
5.5 Other Connections	27

6. Pin Definitions	28
6.1 EFM8UB2x-QFP48 Pin Definitions28
6.2 EFM8UB2x-QFP32 Pin Definitions33
6.3 EFM8UB2x-QFN32 Pin Definitions37
7. QFP48 Package Specifications.	41
7.1 QFP48 Package Dimensions41
7.2 QFP48 PCB Land Pattern43
7.3 QFP48 Package Marking44
8. QFP32 Package Specifications.	45
8.1 QFP32 Package Dimensions45
8.2 QFP32 PCB Land Pattern47
8.3 QFP32 Package Marking48
9. QFN32 Package Specifications.	49
9.1 QFN32 Package Dimensions49
9.2 QFN32 PCB Land Pattern51
9.3 QFN32 Package Marking52
10. Revision History.	53
10.1 Revision 1.353
10.2 Revision 1.253
10.3 Revision 1.153
Table of Contents	54