

EFR32BG27 Wireless Gecko SoC Family

Data Short



The EFR32BG27 Wireless Gecko family of SoCs is part of the Wireless Gecko portfolio. EFR32BG27 Wireless Gecko SoCs are ideal for enabling energy-friendly Bluetooth 5.x networking for IoT devices.

The single-die solution combines a 76.8 MHz Cortex-M33 with a high performance 2.4 GHz radio to provide an industry-leading, energy efficient wireless, SoC for IoT connected applications.

The devices are available with boost or buck DC-DC capabilities, enabling direct power from a wide variety of batteries.

Wireless Gecko applications include:

- Portable Medical
- Home End Devices
- Fleet/Asset Monitoring
- Industrial Automation
- Access Control
- Bluetooth Mesh
- Sports, Fitness, and Wellness devices
- Power Tools

KEY FEATURES

- 32-bit ARM® Cortex®-M33 core with 76.8 MHz maximum operating frequency
- 768 kB of flash and 64 kB of RAM
- Energy-efficient radio core with low active and sleep currents
- Integrated PA with up to 8 dBm (2.4 GHz) TX power
- Secure Boot with Root of Trust and Secure Loader (RTSL)
- Pin compatibility / feature superset with EFR32xG22 in QFN
- DC-DC supporting buck (1.8-3.8 V) or boost (0.8 - 1.7 V) operation
- Available in WLCSP and QFN packaging

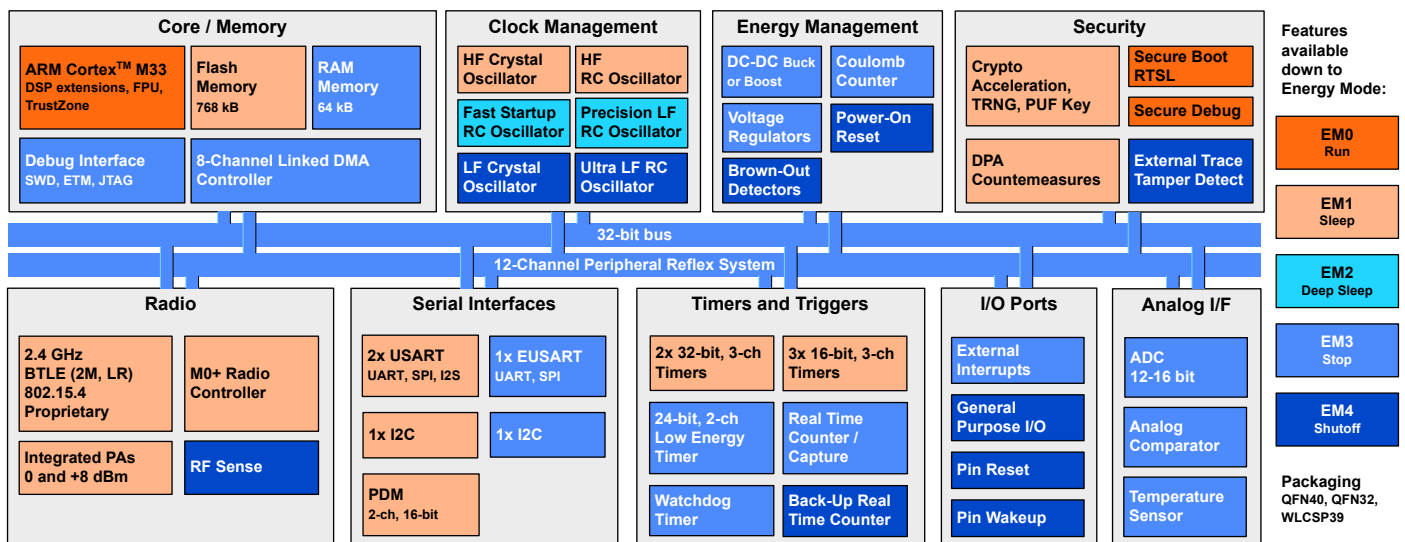

1. Feature List

The EFR32BG27 highlighted features are listed below.

- **Low Power Wireless System-on-Chip**
 - High Performance 32-bit 76.8 MHz ARM Cortex®-M33 with DSP instruction and floating-point unit for efficient signal processing
 - 768 kB flash program memory
 - 64 kB RAM data memory
 - 2.4 GHz radio operation
- **Radio Performance**
 - -106.7 dBm sensitivity @ 125 kbps GFSK
 - -98.9 dBm sensitivity @ 1 Mbit/s GFSK
 - -96.2 dBm sensitivity @ 2 Mbit/s GFSK
 - TX power up to 8 dBm
- **Low System Energy Consumption**
 - 3.6 mA RX current (1 Mbps GFSK)
 - 4.1 mA TX current @ 0 dBm output power
 - 9.2 mA TX current @ 6 dBm output power
 - 11.3 mA TX current @ 8 dBm output power
 - 29 μ A/MHz in Active Mode (EM0) at 76.8 MHz
 - 1.6 μ A EM2 DeepSleep current (64 kB RAM retention and RTC running from LFXO)
 - 0.18 μ A EM4 current
- **Supported Modulation Format**
 - 2 (G)FSK with fully configurable shaping
 - OQPSK DSSS
 - (G)MSK
- **Protocol Support**
 - Bluetooth Low Energy (Bluetooth 5.x)
 - Proprietary
- **Security Features**
 - Secure Boot with Root of Trust and Secure Loader (RTSL)
 - Hardware Cryptographic Acceleration for AES128/256, SHA-1, SHA-2 (up to 256-bit), ECC (up to 256-bit), ECDSA, and ECDH
 - DPA Countermeasures
 - Key Management with PUF
 - True Random Number Generator (TRNG) compliant with NIST SP800-90 and AIS-31
 - ARM® TrustZone®
 - Secure Debug with lock/unlock
 - External Tamper Detect
- **Wide selection of MCU peripherals**
 - Analog to Digital Converter (ADC)
 - 12-bit @ 1 Msps
 - 16-bit @ 76.9 kpsps
 - Analog Comparator (ACMP)
 - Up to 26 General Purpose I/O pins with output state retention and asynchronous interrupts
 - 8 Channel DMA Controller
 - 12 Channel Peripheral Reflex System (PRS)
 - 2 \times 32-bit Timer/Counter with 3 Compare/Capture/PWM channels
 - 3 \times 16-bit Timer/Counter with 3 Compare/Capture/PWM channels
 - 32-bit Real Time Counter
 - 24-bit Low Energy Timer for waveform generation
 - 1 \times Watchdog Timer
 - 2 \times Universal Synchronous/Asynchronous Receiver/Transmitter (UART/SPI/SmartCard (ISO 7816)/IrDA/I²S)
 - 1 \times Enhanced Universal Synchronous/Asynchronous Receiver/Transmitter (UART/SPI)
 - 2 \times I²C interface with SMBus support
 - Digital microphone interface (PDM)
 - Precision Low-Frequency RC Oscillator to replace 32 kHz sleep crystal
 - RFSense with selective OOK mode
 - Die temperature sensor with +/-1.5 degree C accuracy after single-point calibration
 - Coulomb counter integrated into DC-DC
- **Wide Operating Range**
 - 1.8 V to 3.8 V single power supply for devices with Buck DC-DC
 - 0.8 V to 1.7 V single power supply for devices with Boost DC-DC
 - -40 °C to 125 °C
- **Packages**
 - **QFN40** 5 mm \times 5 mm \times 0.85 mm, 0.4 mm pitch
 - **QFN32** 4 mm \times 4 mm \times 0.85 mm, 0.4 mm pitch
 - **WLCSP39** 2.291 mm \times 2.624 mm \times 0.5 mm, 0.35 mm pitch

2. Ordering Information

Table 2.1. Ordering Information

Ordering Code	Protocol Stack	Max TX Power	DC-DC	Flash (kB)	RAM (kB)	GPIO	Package	Temp Range
EFR32BG27C320F768GJ39-B	<ul style="list-style-type: none"> Bluetooth 5.x Direction Finding (AoA Transmitter) Proprietary 	4 dBm	Buck or Boost	768	64	19	WLCSP39	-40 to 85 °C
EFR32BG27C230F768IM40-B	<ul style="list-style-type: none"> Bluetooth 5.x Direction Finding (AoA Transmitter) Proprietary 	6 dBm	Boost	768	64	25	QFN40	-40 to 125 °C
EFR32BG27C230F768IM32-B	<ul style="list-style-type: none"> Bluetooth 5.x Direction Finding (AoA Transmitter) Proprietary 	6 dBm	Boost	768	64	17	QFN32	-40 to 125 °C
EFR32BG27C140F768IM40-B	<ul style="list-style-type: none"> Bluetooth 5.x Direction Finding (AoA Transmitter) Proprietary 	8 dBm	Buck	768	64	26	QFN40	-40 to 125 °C
EFR32BG27C140F768IM32-B	<ul style="list-style-type: none"> Bluetooth 5.x Direction Finding (AoA Transmitter) Proprietary 	8 dBm	Buck	768	64	18	QFN32	-40 to 125 °C

Bluetooth 5.x: As the Bluetooth standard evolves, Silicon Labs is regularly adding new features. For more information on supported Bluetooth capabilities, visit <https://www.silabs.com/bluetooth-hardware>.

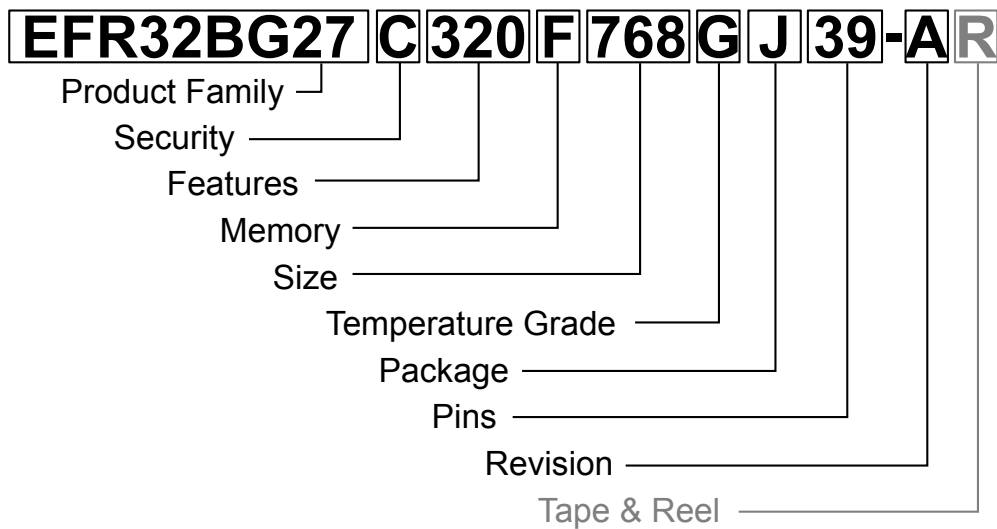

Field	Options
Product Family	<ul style="list-style-type: none"> • EFR32BG27: Wireless Gecko BG27 Family
Security	<ul style="list-style-type: none"> • C: Secure Vault Mid
Features [f1][f2][f3]	<ul style="list-style-type: none"> • f1 <ul style="list-style-type: none"> • 1: DC-DC Buck Converter • 2: DC-DC Boost Converter • 3: DC-DC Buck or Boost Converter • f2 <ul style="list-style-type: none"> • 2: 4 dBm PA Transmit Power • 3: 6 dBm PA Transmit Power • 4: 8 dBm PA Transmit Power • f3 <ul style="list-style-type: none"> • 0: Unused
Memory	<ul style="list-style-type: none"> • F: Flash
Size	<ul style="list-style-type: none"> • Memory Size in kBytes
Temperature Grade	<ul style="list-style-type: none"> • G: -40 to +85 °C • I: -40 to +125 °C
Package	<ul style="list-style-type: none"> • M: QFN • J: WLCSP
Pins	<ul style="list-style-type: none"> • Number of Package Pins
Revision	<ul style="list-style-type: none"> • A: Revision A • B: Revision B
Tape & Reel	<ul style="list-style-type: none"> • R: Tape & Reel (optional)

Figure 2.1. Ordering Code Key

Table of Contents

- 1. Feature List 2
- 2. Ordering Information 3
- 3. Revision History 6

3. Revision History

Revision 0.3

March, 2023

Updated characterization results with latest data.

Revision 0.1

December, 2022

Initial release.