



EFR32FG28 Wireless SoC Family Data Short

The EFR32FG28 SoC is an ideal dual band Sub-GHz + 2.4 GHz BLE SoC solution for “Internet of Things” applications in smart homes, security, lighting, building automation, and metering. This dual band solution combines a high-performance Sub-GHz radio that provides long range capabilities and a 2.4 GHz BLE radio for multiprotocol applications.

The single die, multi-core solution, provides industry leading security, low power consumption with fast wakeup times, and integrated power amplifiers to enable the next level of secure connectivity for IoT devices. Large memory footprint enables flexible solutions for Dynamic Protocol support and the integration of a Matrix Vector Processor empowers AI/ML implementation for Smart End Nodes.

EFR32FG28 applications include:

- Metering
- Home and Building Automation and Security
- Industrial Automation
- Street Lighting

KEY FEATURES

- 32-bit ARM® Cortex®-M33 core with 78 MHz maximum operating frequency
- 1024 kB of flash and up to 256 kB of RAM
- Energy-efficient radio core with low active and sleep currents
- Integrated PAs with up to 20 dBm for sub-GHz and 10 dBm for BLE transmit power
- Robust peripheral set and up to 49 GPIO
- QFN48 and QFN68 package options

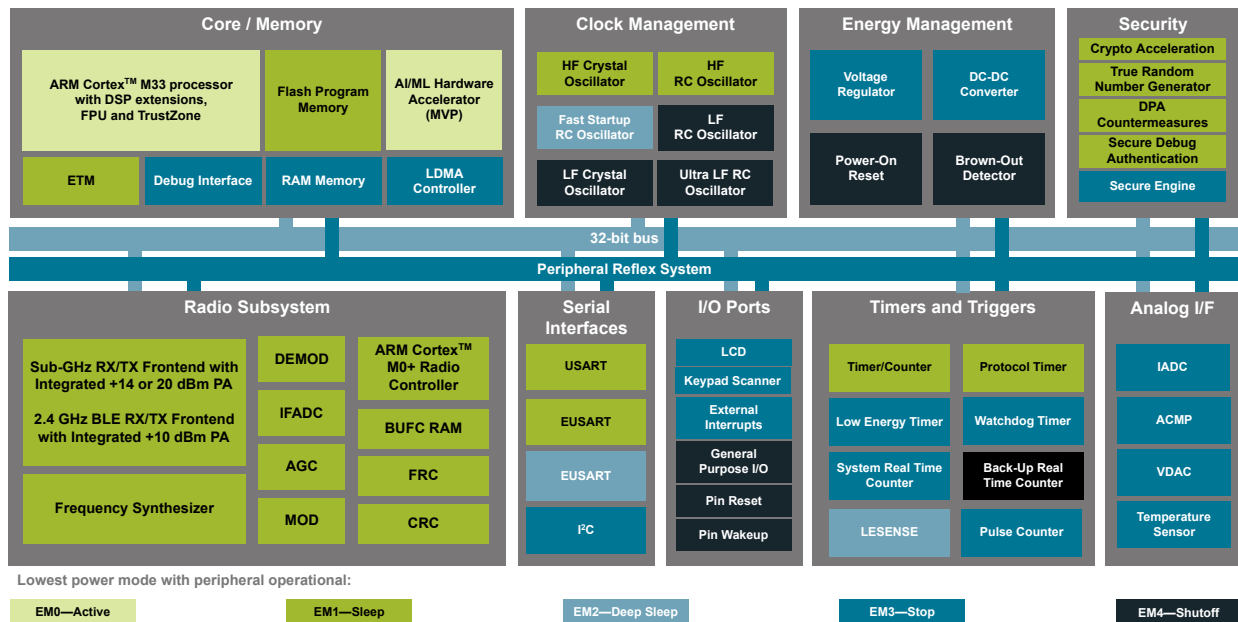

1. Feature List

The EFR32FG28 highlighted features are listed below.

- **Low Power Wireless System-on-Chip**
 - High Performance 32-bit 78 MHz ARM Cortex[®]-M33 with DSP instruction and floating-point unit for efficient signal processing
 - Up to 1024 kB flash program memory
 - Up to 256 kB RAM data memory
 - Sub-GHz radio operation with TX power up to +20 dBm
 - 2.4 GHz BLE radio operation with TX power up to +10 dBm
 - Matrix Vector Processor for AI/ML acceleration
- **Low Energy Consumption**
 - 5 mA RX current at 920 MHz (400 kbps 4-FSK)
 - 4.6 mA RX current at 915 MHz (4.8 kbps O-QPSK)
 - 6.1 mA RX current at 915 MHz (2 Mbps GFSK)
 - 4.6 mA RX current at 868 MHz (2.4 kbps GFSK)
 - 4.6 mA RX current at 868 MHz (38.4 kbps FSK)
 - 4.1 mA RX current at 433 MHz (100 kbps 2GFSK)
 - 5.2 mA RX current at 2.4 GHz, 1 Mbps BLE
 - 26.2 mA TX current @ 14 dBm output power at 915 MHz (14 dBm part numbers)
 - 12.2 mA TX current @ 0 dBm output power, 2.4 GHz
 - 22.5 mA TX current @ 10 dBm output power, 2.4 GHz
 - 33 μ A/MHz in Active Mode (EM0) at 39.0 MHz
 - 2.8 μ A EM2 DeepSleep current (256 kB RAM retention and RTC running from LFXO)
 - 1.3 μ A EM2 DeepSleep current (16 kB RAM retention and RTC running from LFRCO)
 - Preamble Sense Mode (PSM) low duty-cycle listen
- **High Receiver Performance**
 - -98.6 dBm sensitivity @ 400 kbps 920 MHz 4-GFSK
 - -125.8 dBm sensitivity @ 4.8 kbps 915 MHz O-QPSK
 - -96.9 dBm sensitivity @ 2 Mbps 915 MHz GFSK
 - -125.3 dBm sensitivity @ 2.4 kbps 868 MHz GFSK
 - -111.5 dBm sensitivity @ 38.4 kbps 868 MHz FSK
 - -110.7 dBm sensitivity @ 100 kbps 433 MHz 2GFSK
- **Supported Modulation Format**
 - 2/4 (G)FSK with fully configurable shaping
 - OQPSK DSSS
 - (G)MSK
 - OOK
- **Protocol Support**
 - Proprietary
 - CONNECT
 - Amazon Sidewalk
 - WM-BUS
 - Wi-SUN
 - Bluetooth Low Energy
- **Wide selection of MCU peripherals**
 - Analog to Digital Converter (ADC)
 - 12-bit @ 1 Msps
 - 16-bit @ 76.9 kbps
 - 2 \times Analog Comparator (ACMP)
 - 2-Channel Digital to Analog Converter (VDAC)
 - Low-Energy Sensor Interface (LESENSE)
 - Up to 49 General Purpose I/O pins with output state retention and asynchronous interrupts
 - 8 Channel DMA Controller
 - 12 Channel Peripheral Reflex System (PRS)
 - 4 \times 16-bit Timer/Counter with 3 Compare/Capture/PWM channels
 - 1 \times 32-bit Timer/Counter with 3 Compare/Capture/PWM channels
 - 32-bit Real Time Counter
 - 24-bit Low Energy Timer for waveform generation
 - 16-bit Pulse Counter with asynchronous operation (PCNT)
 - 2 \times Watchdog Timer
 - 3 \times Enhanced Universal Synchronous/Asynchronous Receiver/Transmitter (EUSART)
 - 1 \times Universal Synchronous/Asynchronous Receiver/Transmitter (UART/SPI/SmartCard (ISO 7816)/IrDA/I²S)
 - 2 \times I²C interface with SMBus support
 - Integrated Low-Energy LCD Controller supporting up to 192 segments
 - Keypad scanner supporting up to 6 \times 8 matrix (KEYSCAN)
 - Die temperature sensor with ± 2 $^{\circ}$ C typical accuracy across temperature range
- **Secure Vault**
 - Hardware Cryptographic Acceleration for AES128/192/256, ChaCha20-Poly1305, SHA-1, SHA-2/256/384/512, ECDSA +ECDH(P-192, P-256, P-384, P-521), Ed25519 and Curve25519, J-PAKE, PBKDF2
 - True Random Number Generator (TRNG)
 - ARM[®] TrustZone[®]
 - Secure Boot (Root of Trust Secure Loader)
 - Secure Debug Unlock
 - DPA Countermeasures
 - Secure Key Management with PUF
 - Anti-Tamper
 - Secure Attestation
- **Wide Operating Range**
 - 1.71 V to 3.8 V single power supply
 - -40 $^{\circ}$ C to +125 $^{\circ}$ C
- **Packages**
 - **QFN68** 8 mm \times 8 mm \times 0.85 mm
 - **QFN48** 6 mm \times 6 mm \times 0.85 mm

2. Ordering Information

Table 2.1. Ordering Information

Ordering Code	Sub-GHz TX Power	BLE TX Power	Flash (kB)	RAM (kB)	Secure Vault	GPIO	Matrix Vector Processor	Package	Temp Range
EFR32FG28B322F1024IM68-A	20 dBm	10 dBm	1024	256	High	49	Yes	QFN68 Dual-Band	-40 to 125 °C
EFR32FG28B322F1024IM48-A	20 dBm	10 dBm	1024	256	High	31	Yes	QFN48 Dual-Band	-40 to 125 °C
EFR32FG28B320F1024IM68-A	20 dBm	n/a	1024	256	High	49	Yes	QFN68 Sub-GHz	-40 to 125 °C
EFR32FG28B320F1024IM48-A	20 dBm	n/a	1024	256	High	31	Yes	QFN48 Sub-GHz	-40 to 125 °C
EFR32FG28B312F1024IM68-A	14 dBm	10 dBm	1024	256	High	49	Yes	QFN68 Dual-Band	-40 to 125 °C
EFR32FG28B312F1024IM48-A	14 dBm	10 dBm	1024	256	High	31	Yes	QFN48 Dual-Band	-40 to 125 °C
EFR32FG28B310F1024IM68-A	14 dBm	n/a	1024	256	High	49	Yes	QFN68 Sub-GHz	-40 to 125 °C
EFR32FG28B310F1024IM48-A	14 dBm	n/a	1024	256	High	31	Yes	QFN48 Sub-GHz	-40 to 125 °C
EFR32FG28A122F1024GM68-A	20 dBm	10 dBm	1024	256	Mid	49	No	QFN68 Dual-Band	-40 to 85 °C
EFR32FG28A122F1024GM48-A	20 dBm	10 dBm	1024	256	Mid	31	No	QFN48 Dual-Band	-40 to 85 °C
EFR32FG28A120F1024GM68-A	20 dBm	n/a	1024	256	Mid	49	No	QFN68 Sub-GHz	-40 to 85 °C
EFR32FG28A120F1024GM48-A	20 dBm	n/a	1024	256	Mid	31	No	QFN48 Sub-GHz	-40 to 85 °C
EFR32FG28A112F1024GM68-A	14 dBm	10 dBm	1024	256	Mid	49	No	QFN68 Dual-Band	-40 to 85 °C
EFR32FG28A112F1024GM48-A	14 dBm	10 dBm	1024	256	Mid	31	No	QFN48 Dual-Band	-40 to 85 °C
EFR32FG28A110F1024GM68-A	14 dBm	n/a	1024	256	Mid	49	No	QFN68 Sub-GHz	-40 to 85 °C
EFR32FG28A110F1024GM48-A	14 dBm	n/a	1024	256	Mid	31	No	QFN48 Sub-GHz	-40 to 85 °C
EFR32FG28A010F1024GM68-A	14 dBm	n/a	1024	128	Mid	49	No	QFN68 Sub-GHz	-40 to 85 °C
EFR32FG28A010F1024GM48-A	14 dBm	n/a	1024	128	Mid	31	No	QFN48 Sub-GHz	-40 to 85 °C

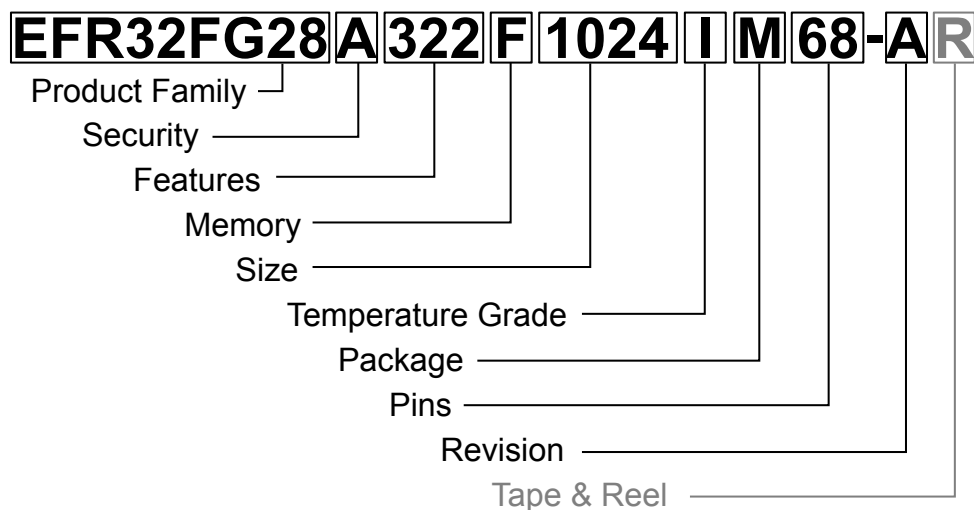

Field	Options
Product Family	<ul style="list-style-type: none"> • EFR32FG28: Wireless Gecko Flex 28 Family
Security	<ul style="list-style-type: none"> • A: Secure Vault Mid • B: Secure Vault High
Features [f1][f2][f3]	<ul style="list-style-type: none"> • f1 <ul style="list-style-type: none"> • 0: 8-to-1 Flash / RAM ratio, no MVP • 1: 4-to-1 Flash / RAM ratio, no MVP • 2: Unused • 3: 4-to-1 Flash / RAM ratio, with MVP • f2, f3 <ul style="list-style-type: none"> • 10: Two 14 dBm Sub-GHz PAs (RF0 and RF1) • 12: One 14 dBm Sub-GHz PA (RF1) and one 10 dBm BLE 2.4 GHz PA (RF0) • 20: Two 20 dBm Sub-GHz PAs (RF0 and RF1) • 22: One 20 dBm Sub-GHz PA (RF1) and one 10 dBm BLE 2.4 GHz PA (RF0)
Memory	<ul style="list-style-type: none"> • F: Flash
Size	<ul style="list-style-type: none"> • Memory Size in kBytes
Temperature Grade	<ul style="list-style-type: none"> • G: -40 to +85 °C • I: -40 to +125 °C
Package	<ul style="list-style-type: none"> • M: QFN
Pins	<ul style="list-style-type: none"> • Number of Package Pins
Revision	<ul style="list-style-type: none"> • A: Revision A
Tape & Reel	<ul style="list-style-type: none"> • R: Tape & Reel (optional)

Figure 2.1. Ordering Code Key