

PARTS LIST

Reference	Manufacturer Part #	Description	QTY
<u>Printed Circuit Board</u>			
EVAL 18	EVAL18	Printed Circuit Board	1
<u>Capacitors</u>			
CVs, CVcc	1825RB105K201N	1uF,200V CAP - NOVACOP	
<u>Resistors</u>			
Ra, Rb	MP-725-0.10-1%	Resister, 0.10 Ω	2
Ra, Rb	MP-725-0.05-1%	Resistor, 0.05 Ω	2
<u>Hardware</u>			
	HS21	Heatsink	1
	TW09	Thermal Washer (Pack of 10 pcs)	1
	CLAMP02	Mounting Clip	1

BEFORE YOU GET STARTED

- SA09 amplifier is not included with the EK09 kit and must be purchased separately.
- All APEX amplifiers should be handled using proper ESD precautions.
- Always use a thermal washer between the amplifier and heatsink.
- Always use adequate power supply bypassing.
- Do not change connections while the circuit is powered.
- Initially set all power supplies to the minimum operating levels allowed in the device data sheet.

ASSEMBLY

See Figure 3.

1. Solder the surface mount ceramic capacitors to the bottom side of the circuit board at CVs and CVcc.
2. Select a current limiting resistor from the two values provided. See the product data sheet for information on how to select a value. Apply a thin coating of thermal grease to the back of the resistors. Press the resistor body onto the circuit board foil at positions Ra and Rb and solder the leads.
3. Assemble the amplifier, thermal washer and heat sink to the circuit board as illustrated in Figure 3. As a last step push the clip through the heat sink and circuit board until it locks. Solder the amplifier pins to the bottom side of the circuit board.
4. The four holes at the corners of the circuit board are for mounting #6 standoff spacers (not included) if desired.
5. Add other components as necessary to complete your application circuit.

Figure 2:

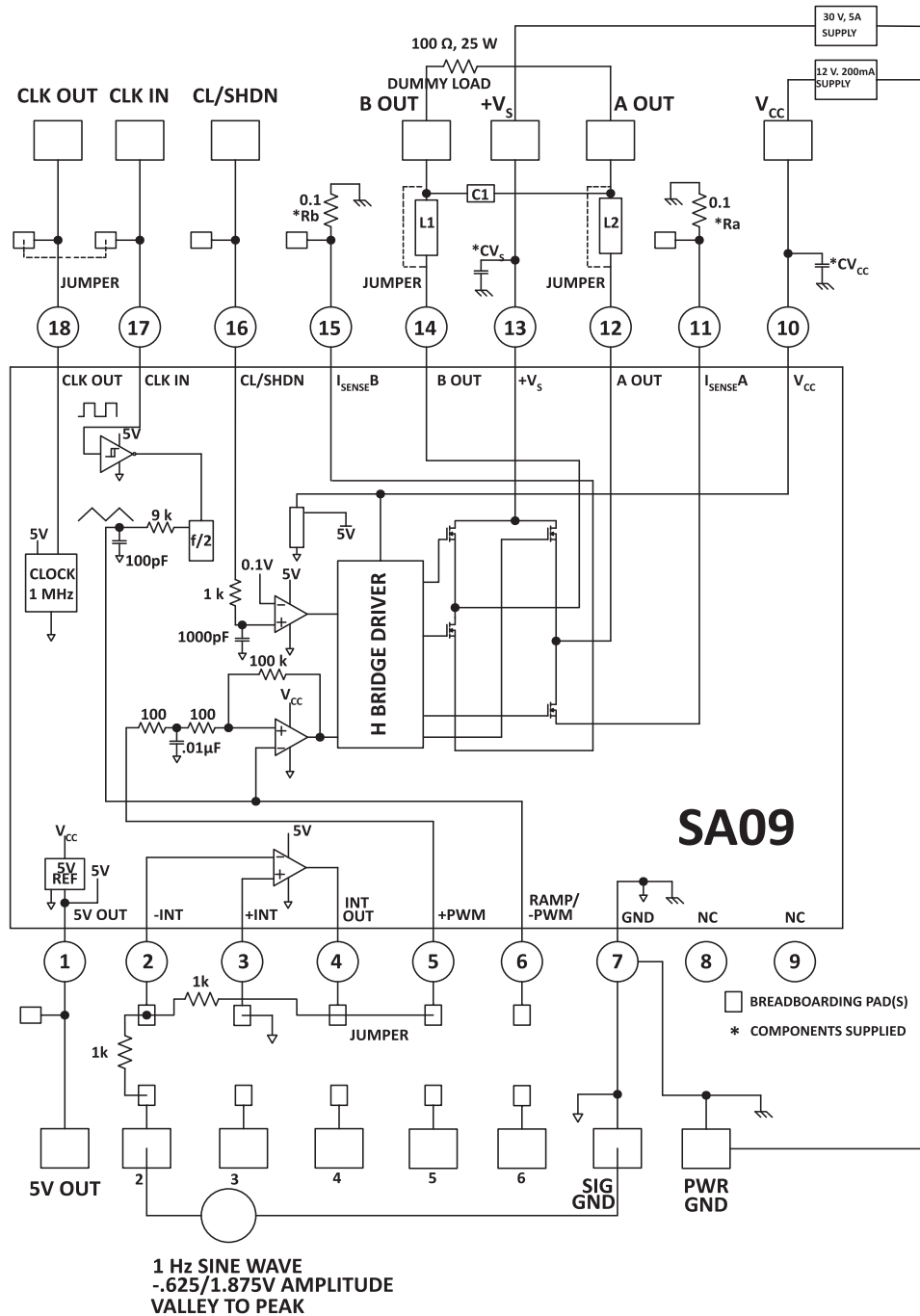

Figure 2 shows a suggested simple test circuit that you can build to gain a familiarity with the evaluation kit as well as the amplifier. At the A OUT or B OUT pads relative to power ground you should observe a square wave with a frequency of approximately 500kHz, 30V p-p which is being modulated from approximately 0 to 100% duty cycle at a rate of 1 Hz.

Figure 3: PCB

