

Power Booster Evaluation Kit

APPLICABLE PARTS (SOLD SEPARATELY)

- PB51

INTRODUCTION

This easy-to-use kit provides a platform for the evaluation of the PB51 high voltage power boosters. The PB51 is designed most commonly in combination with a small signal, general purpose op amp. However, they can also be used without a driver amplifier. This kit can be used to analyze a multitude of standard or proprietary circuit configurations.

CAUTION Use the supplied thermal washers or thermal grease between the power amplifier and the heat sink.

Figure 1: PCB

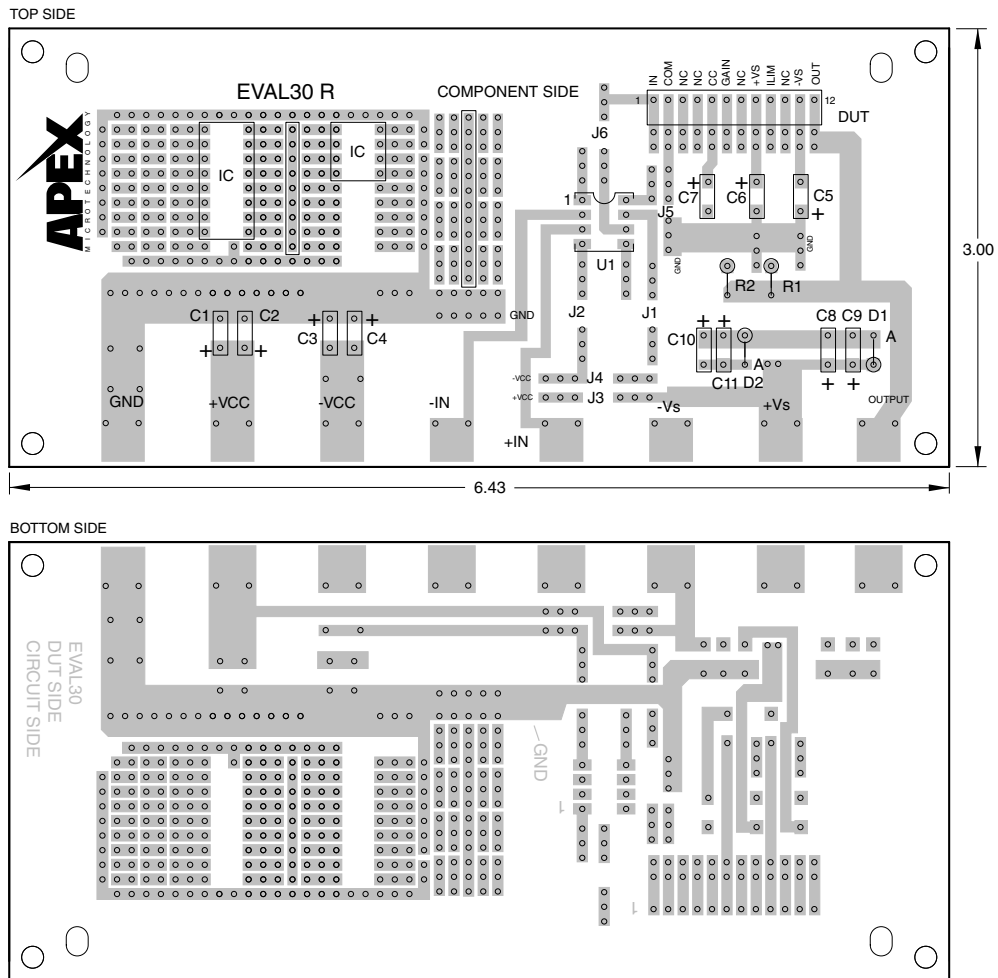
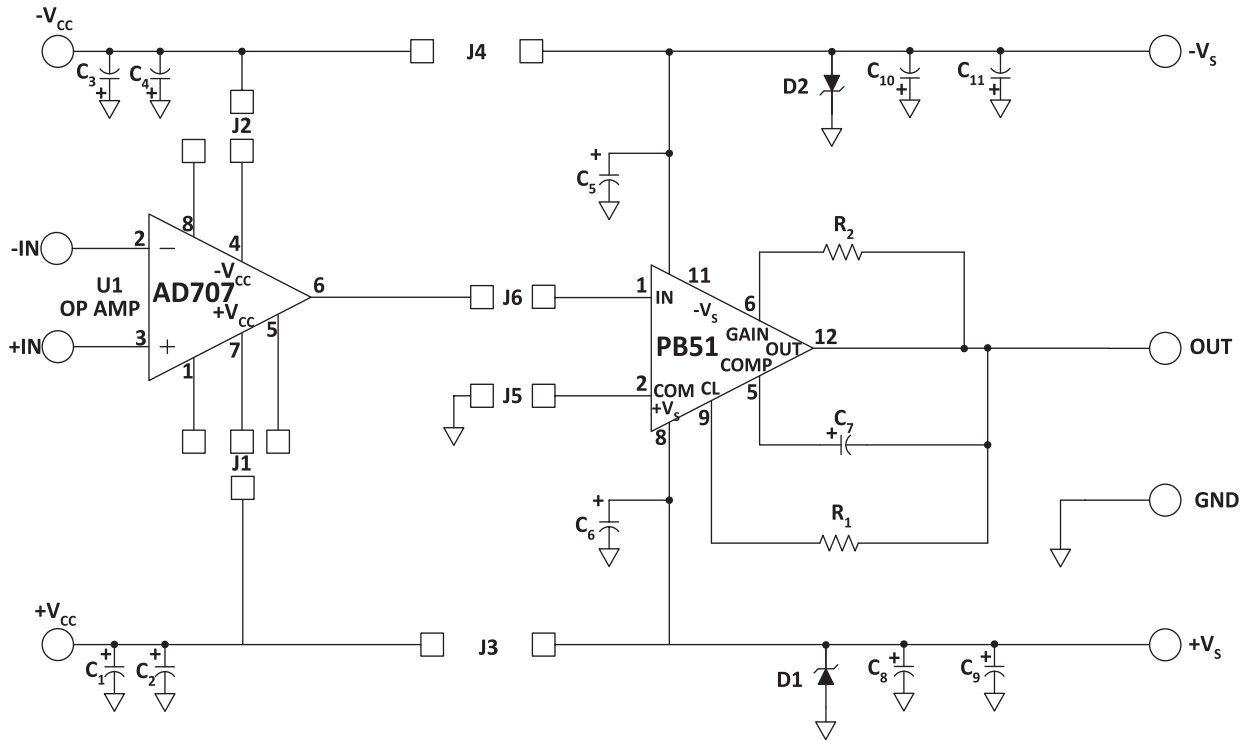

Figure 2: EK Schematic



PARTS LIST

Reference	Manufacturer Part #	Description	QTY
	HS20	Heatsink	1
	EVAL30	PC Board	1
	MS06	Mating Socket	1
	TW07	Thermal Washer	1 Package

BEFORE YOU GET STARTED

- All Apex Microtechnology amplifiers should be handled using proper ESD precautions.
- Always use the heat sink and thermal washers included in this kit.
- Always use adequate power supply bypassing.
- Do not change connections while the circuit is powered.
- Initially set all power supplies to the minimum operating levels allowed in the device data sheet.
- Check for oscillations.

ASSEMBLY

1. On the silk screen side of the evaluation board, insert and solder the MS06 mating socket in DUT holes 1-12. Be sure each one is fully seated.
2. Solder components for your circuit. Be sure to include proper bypassing, required compensation components and current limit resistors. See the op amp data sheet for help in selecting these components.
3. Place the TW07 thermal washer on the heat sink over the mounting hole for the DUT. Place a #6 screw through the mounting hole and thread a #6 nut onto the screw at the back of the heat sink. Do not tighten. Note that there are two sets of mounting holes on the HS20. Holes on one edge allow room between the DUT and evaluation board for the MS06 socket. The holes on the other edge are for direct through hole mounting of the DUT to the evaluation board. It is recommended that you use the MS06.
4. Mount the DUT to the HS20 by sliding under the head of the #6 screw and on top of the thermal washer. Tighten the nut to the specified 8 to 10 in-lbs. (0.9 to 0.13 N*m) do not over torque.
5. Install leads of the DUT into the MS06 on the evaluation board. Use #6 self-tapping screws to secure the evaluation board to the HS20 heatsink as shown in the assembly diagram (Figure 3).

Figure 3: Assembly

