

# PE423641

UltraCMOS® SP4T RF Switch  
50–3000 MHz

### Features

- AEC-Q100 Grade 2 certified
- Supports operating temperature up to +105°C
- HaRP™ technology enhancements provide excellent linearity
  - Low harmonics of  $2f_0 = -83$  dBc and  $3f_0 = -77$  dBc @ +35 dBm
  - IMD3 of  $-111$  dBm @ WCDMA band 1
  - IIP3 of 68 dBm
- Low insertion loss
  - 0.50 dB @ 1000 MHz
  - 0.65 dB @ 2200 MHz
- High isolation
  - 32 dB @ 1000 MHz
  - 25 dB @ 2200 MHz
- High ESD performance
  - 2 kV HBM on all pins
  - 100V MM on all pins
  - 1 kV CDM on all pins
- Integrated decoder for 2-pin control
  - Accepts 1.8V and 2.75V levels

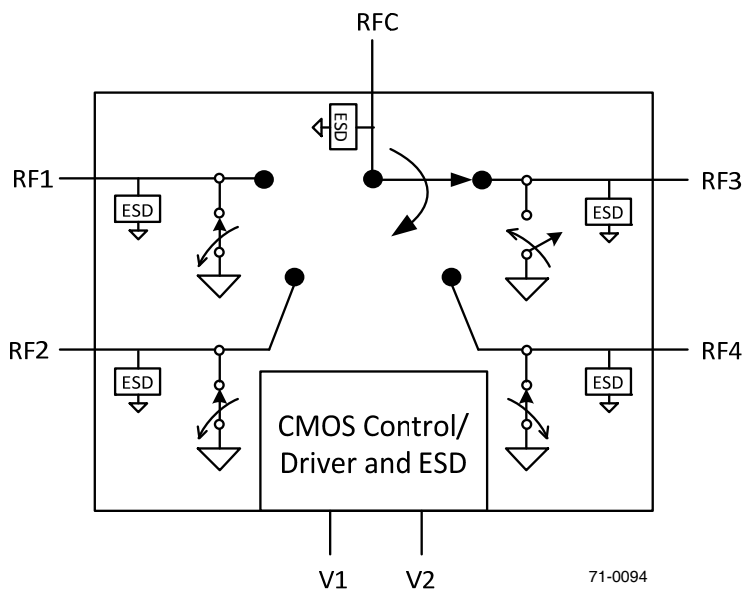
### Product Description

The PE423641 is a HaRP™ technology-enhanced reflective SP4T RF switch. It has received AEC-Q100 Grade 2 certification and meets the quality and performance standards that makes it suitable for use in harsh automotive environments. It is designed to cover a wide range of wireless applications from 50 MHz through 3 GHz such as cellular antenna band switching, automotive infotainment and traffic safety applications. No blocking capacitors are required if DC voltage is not present on the RF ports.

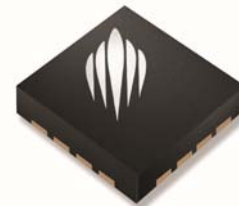
The PE423641 is manufactured on Peregrine's UltraCMOS® process, a patented variation of silicon-on-insulator (SOI) technology on a sapphire substrate, offering excellent RF performance.

Peregrine's HaRP™ technology enhancements deliver high linearity and excellent harmonics performance. It is an innovative feature of the UltraCMOS process, offering the performance of GaAs with the economy and integration of conventional CMOS.

**Figure 1. Functional Diagram**



**Figure 2. Package Type**  
16-lead 3 x 3 mm QFN



**Table 1. Electrical Specifications @ +25°C, V<sub>DD</sub> = 2.75V (Z<sub>S</sub> = Z<sub>L</sub> = 50Ω)**

Parameter	Path	Condition	Min	Typ	Max	Unit
Operational frequency			50		3000	MHz
Insertion loss (symmetric ports)	RFC–RFX	50–1000 MHz		0.50	0.60	dB
		1000–2200 MHz		0.65	0.75	dB
		2200–2700 MHz		0.80	0.95	dB
		2700–3000 MHz		0.95	1.15	dB
Isolation	RFC–RFX	50–1000 MHz	30	32		dB
		1000–2200 MHz	23	25		dB
		2200–2700 MHz	21	23		dB
		2700–3000 MHz	20	22		dB
Return loss (active ports)	RFC–RFX	50–1000 MHz		24		dB
		1000–2200 MHz		19		dB
		2200–2700 MHz		16		dB
		2700–3000 MHz		14		dB
Return loss (common ports)	RFC–RFX	50–1000 MHz		23		dB
		1000–2200 MHz		16		dB
		2200–2700 MHz		14		dB
		2700–3000 MHz		13		dB
2nd harmonic	RFX	+35 dBm output power, 850/900 MHz		–83	–80	dBc
		+33 dBm output power, 1800/1900 MHz		–85	–78	dBc
3rd harmonic	RFX	+35 dBm output power, 850/900 MHz		–77	–73.5	dBc
		+33 dBm output power, 1800/1900 MHz		–78	–72.5	dBc
IMD3		RF Measured at 2.14 GHz at ANT port, input +20 dBm CW signal at 1.95 GHz and –15 dBm CW signal at 1.76 GHz		–111		dBm
Input IP2	RFC–RFX	50–3000 MHz		115		dBm
Input IP3	RFC–RFX	50–3000 MHz		68		dBm
Input 0.1 dB compression point <sup>1</sup>	RFC–RFX	50–3000 MHz		37		dBm
Switching time		50% CTRL to 90% or 10% RF		1	2	μs

Note 1: Input 0.1 dB compression point is a linearity figure of merit. Refer to *Table 3* for the operating RF input power (50Ω).

**Table 1A. Electrical Specifications @ -40 to +105°C, V<sub>DD</sub> = 2.75V (Z<sub>S</sub> = Z<sub>L</sub> = 50Ω)**

Parameter	Path	Condition	Min	Typ	Max	Unit
Operational frequency			50		3000	MHz
Insertion loss (symmetric ports)	RFC-RFX	50–1000 MHz		0.50	0.75	dB
		1000–2200 MHz		0.65	0.90	dB
		2200–2700 MHz		0.80	1.10	dB
		2700–3000 MHz		0.95	1.30	dB
Isolation	RFC-RFX	50–1000 MHz	30	32		dB
		1000–2200 MHz	23	25		dB
		2200–2700 MHz	21	23		dB
		2700–3000 MHz	20	22		dB
Return loss (active ports)	RFC-RFX	50–1000 MHz		24		dB
		1000–2200 MHz		19		dB
		2200–2700 MHz		16		dB
		2700–3000 MHz		14		dB
Return loss (common ports)	RFC-RFX	50–1000 MHz		23		dB
		1000–2200 MHz		16		dB
		2200–2700 MHz		14		dB
		2700–3000 MHz		13		dB
2nd harmonic	RFX	+35 dBm output power, 850/900 MHz		-83	-76	dBc
		+33 dBm output power, 1800/1900 MHz		-85	-74	dBc
3rd harmonic	RFX	+35 dBm output power, 850/900 MHz		-77	-69.5	dBc
		+33 dBm output power, 1800/1900 MHz		-78	-68.5	dBc
IMD3		RF Measured at 2.14 GHz at ANT port, input +20 dBm CW signal at 1.95 GHz and -15 dBm CW signal at 1.76 GHz		-111		dBm
Input IP2	RFC-RFX	50–3000 MHz		115		dBm
Input IP3	RFC-RFX	50–3000 MHz		68		dBm
Input 0.1 dB compression point <sup>1</sup>	RFC-RFX	50–3000 MHz		37		dBm
Switching time		50% CTRL to 90% or 10% RF		1	2	μs

Note 1: Input 0.1 dB compression point is a linearity figure of merit. Refer to Table 3 for the operating RF input power (50Ω).

Figure 3. Pin Configuration (Top View)

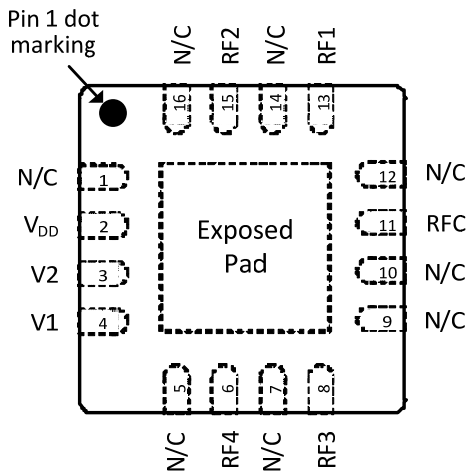


Table 2. Pin Descriptions

Pin #	Pin Name	Description
1, 5, 7, 9, 10, 12, 14, 16	N/C	No connect
2	V <sub>DD</sub>	Supply voltage
3	V2	Digital control logic input 2
4	V1	Digital control logic input 1
6	RF4 <sup>1</sup>	RF port
8	RF3 <sup>1</sup>	RF port
11	RFC <sup>1</sup>	RF common
13	RF1 <sup>1</sup>	RF port
15	RF2 <sup>1</sup>	RF port
Pad	GND	Exposed pad: Ground for proper operation

Note 1: RF pins 6, 8, 13, and 15 must be at 0 VDC. The RF pins do not require DC blocking capacitors for proper operation if the 0 VDC requirement is met.

Table 3. Operating Ranges

Parameter	Symbol	Min	Typ	Max	Unit
Supply voltage	V <sub>DD</sub>	2.65	2.75	3.3	V
Supply current (V <sub>DD</sub> = 2.75V, +25°C only)	I <sub>DD</sub>		13	50	μA
Digital input high (V1, V2)	V <sub>IH</sub>	1.4		V <sub>DD</sub>	V
Digital input low (V1, V2)	V <sub>IL</sub>	0		0.4	V
RF input power, CW <sup>1</sup>	P <sub>MAX,CW</sub>			+35	dBm
Operating temperature range	T <sub>OP</sub>	-40	+25	+105	°C

Note 1: 100% duty cycle, all bands, 50Ω

Table 4. Absolute Maximum Ratings

Parameter/Condition	Symbol	Min	Max	Unit
Supply voltage	V <sub>DD</sub>	-0.3	3.7	V
Digital input voltage (V1, V2)	V <sub>I</sub>	-0.3	3.7	V
RF input power, max	P <sub>MAX,ABS</sub>		+37	dBm
Storage temperature range	T <sub>ST</sub>	-65	+150	°C
ESD voltage HBM <sup>1</sup> , all pins	V <sub>ESD,HBM</sub>		2000	V
ESD voltage MM <sup>2</sup> , all pins	V <sub>ESD,MM</sub>		100	V
ESD voltage CDM <sup>3</sup> , all pins	V <sub>ESD,CDM</sub>		1000	V

Notes: 1. Human Body Model (MIL-STD-883 Method 3015)  
2. Machine Model (JEDEC JESD22-A115)  
3. Charged Device Model (JEDEC JESD22-C101)

Exceeding absolute maximum ratings may cause permanent damage. Operation should be restricted to the limits in the Operating Ranges table. Operation between operating range maximum and absolute maximum for extended periods may reduce reliability.

### Electrostatic Discharge (ESD) Precautions

When handling this UltraCMOS device, observe the same precautions that you would use with other ESD-sensitive devices. Although this device contains circuitry to protect it from damage due to ESD, precautions should be taken to avoid exceeding the specified rating.

### Latch-Up Avoidance

Unlike conventional CMOS devices, UltraCMOS devices are immune to latch-up.

### Moisture Sensitivity Level

The Moisture Sensitivity Level rating for the PE423641 in the 16-lead 3x3 mm QFN package is MSL1.

**Table 5. Truth Table**

Path	V2	V1
RFC-RF1	0	0
RFC-RF2	1	0
RFC-RF3	0	1
RFC-RF4	1	1

### Switching Frequency

The PE423641 has a maximum 25 kHz switching frequency.

Switching frequency describes the time duration between switching events. Switching time is the time duration between the point the control signal reaches 50% of the final value and the point the output signal reaches within 10% or 90% of its target value. Switching time is provided in *Table 1* and *Table 1A*.

Typical Performance Data @ +25°C and  $V_{DD} = 2.75V$ , unless otherwise specified

Figure 4. Insertion Loss vs Temp (RFC-RFX)

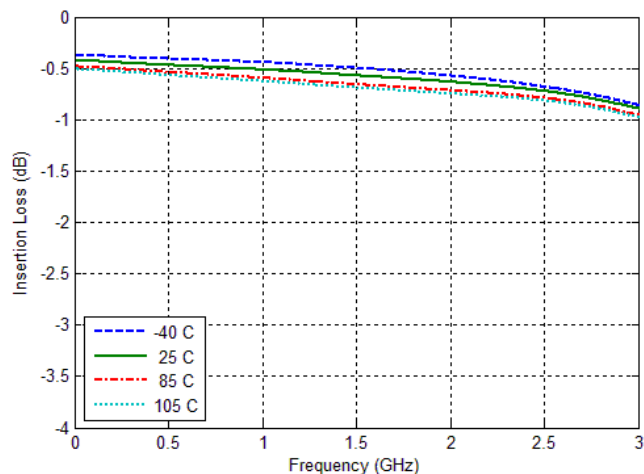


Figure 5. Insertion Loss vs  $V_{DD}$  (RFC-RFX)

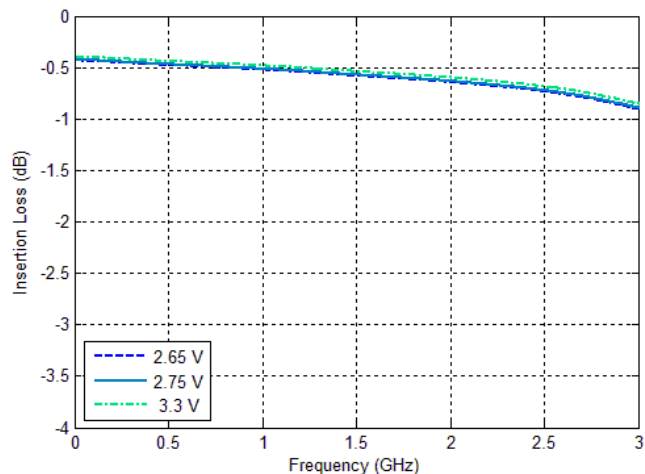


Figure 6. Return Loss vs Temp (Active Port)

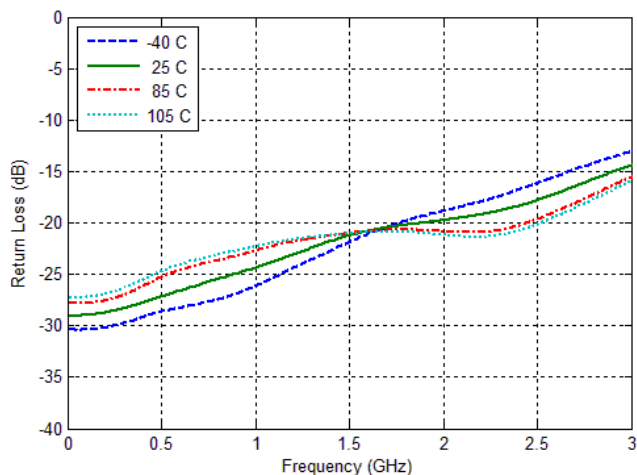


Figure 7. Return Loss vs  $V_{DD}$  (Active Port)

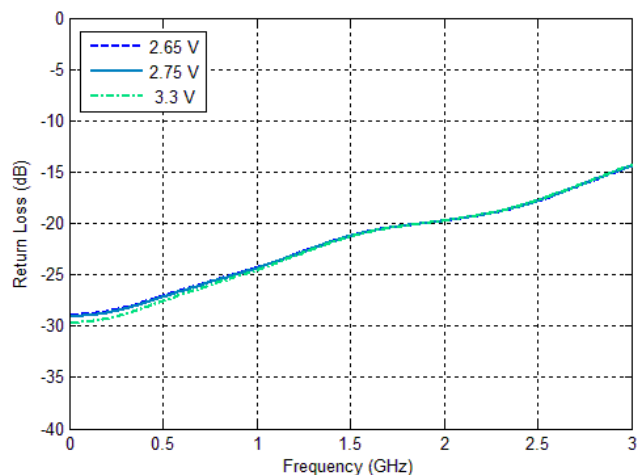


Figure 8. Return Loss vs Temp (Common Port)

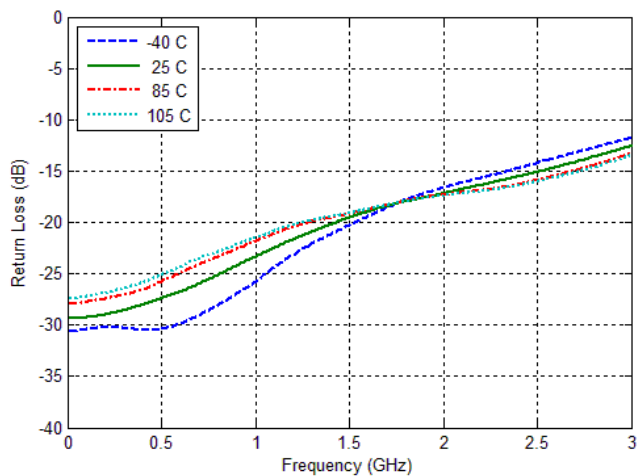
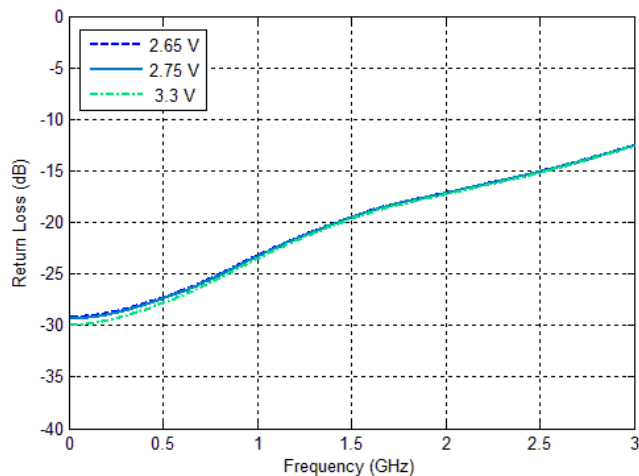


Figure 9. Return Loss vs  $V_{DD}$  (Common Port)



Typical Performance Data @ +25°C and  $V_{DD} = 2.75V$ , unless otherwise specified

Figure 10. Isolation vs Temp (RFC–RFX)

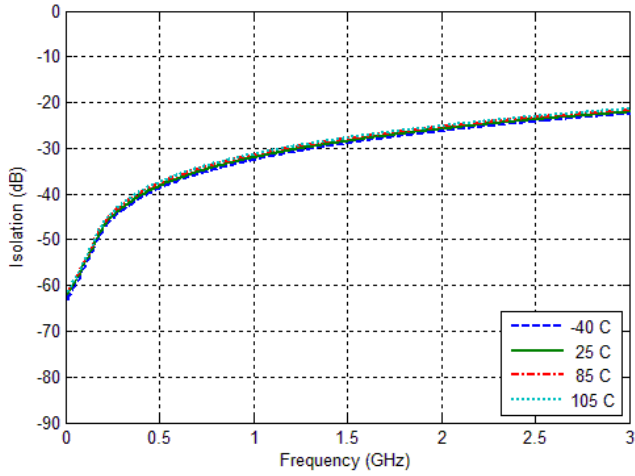
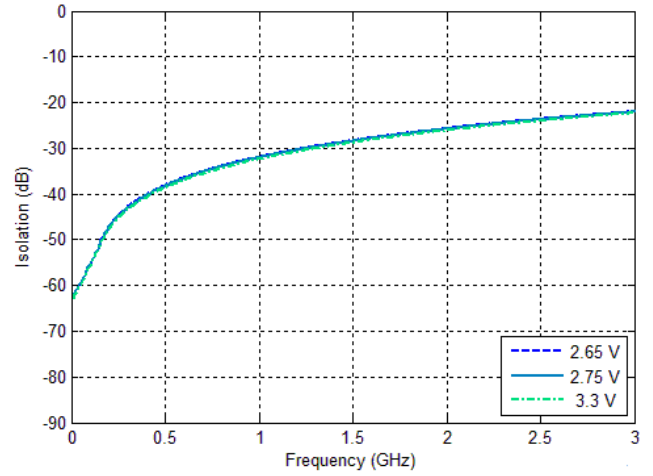


Figure 11. Isolation vs  $V_{DD}$  (RFC–RFX)

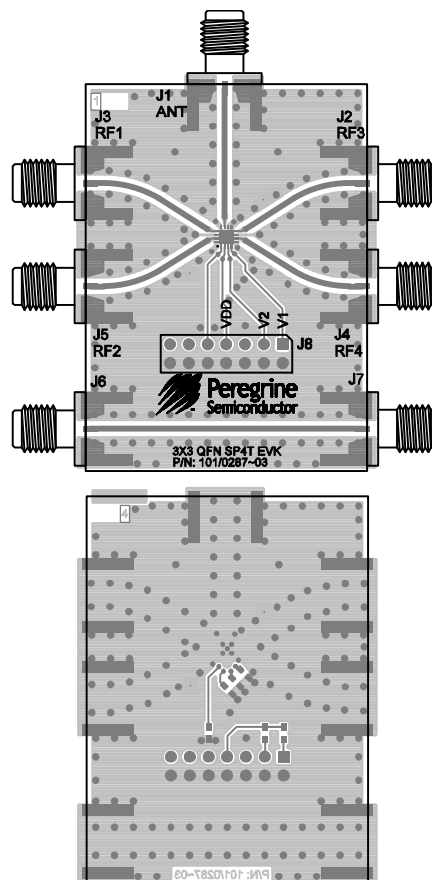


## Evaluation Kit

The SP4T switch evaluation board was designed to ease customer evaluation of Peregrine's PE423641. The RF common port is connected through a 50Ω transmission line via the top SMA connector, J1. RF1, RF2, RF3 and RF4 are connected through 50Ω transmission lines via SMA connectors J3, J5, J2 and J4, respectively. A through 50Ω transmission is available via SMA connectors J6 and J7. This transmission line can be used to estimate the loss of the PCB over the environmental conditions being evaluated.

The board is constructed of a four metal layer FR4 material with a total thickness of 62 mils. The middle layers provide ground for the transmission lines. The transmission lines were designed using a coplanar waveguide with ground plane model using a trace width of 32 mils, trace gaps of 25 mils, and metal thickness of 2.1 mils.

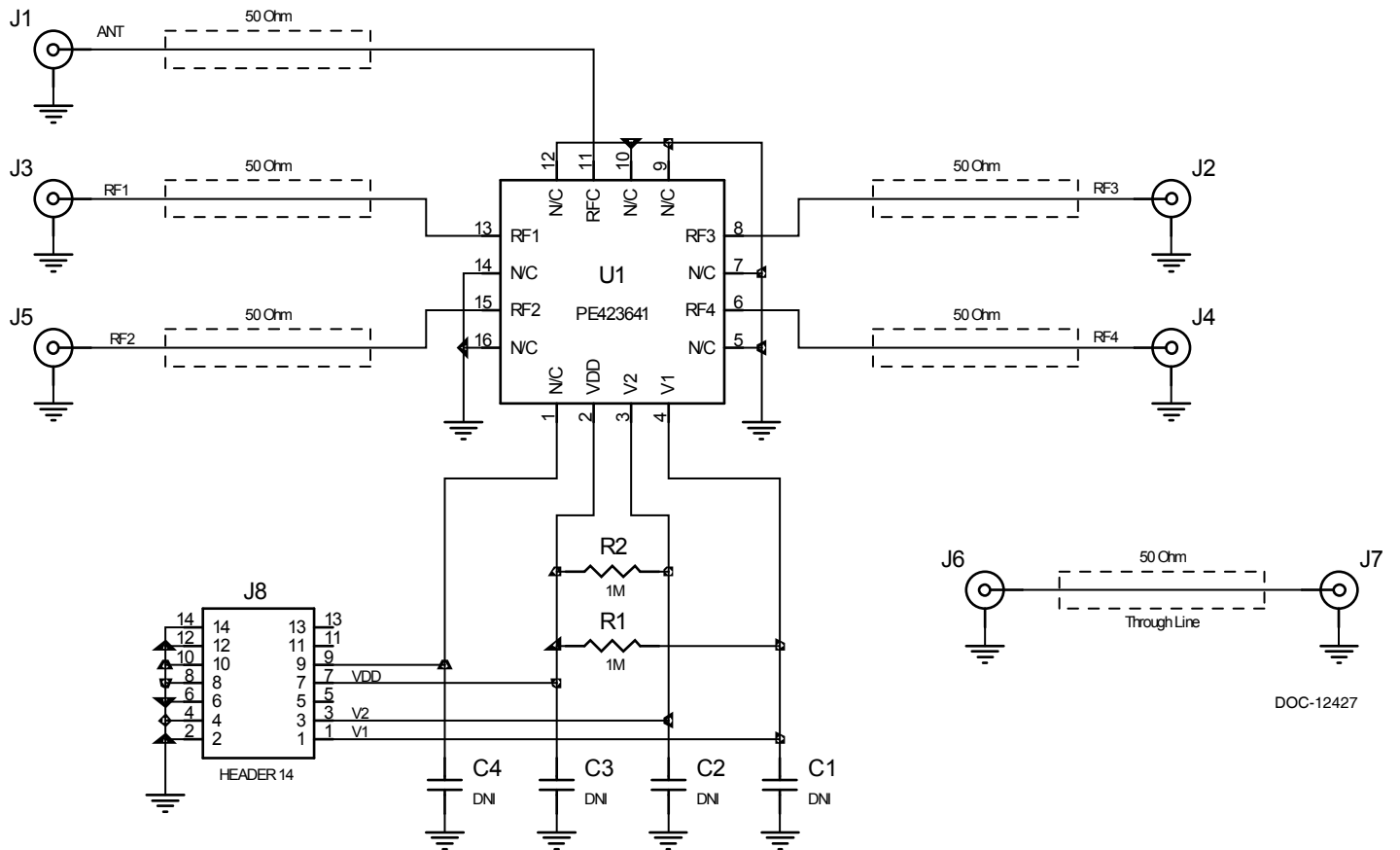
**Figure 12. Evaluation Board Layouts**



PRT-50900

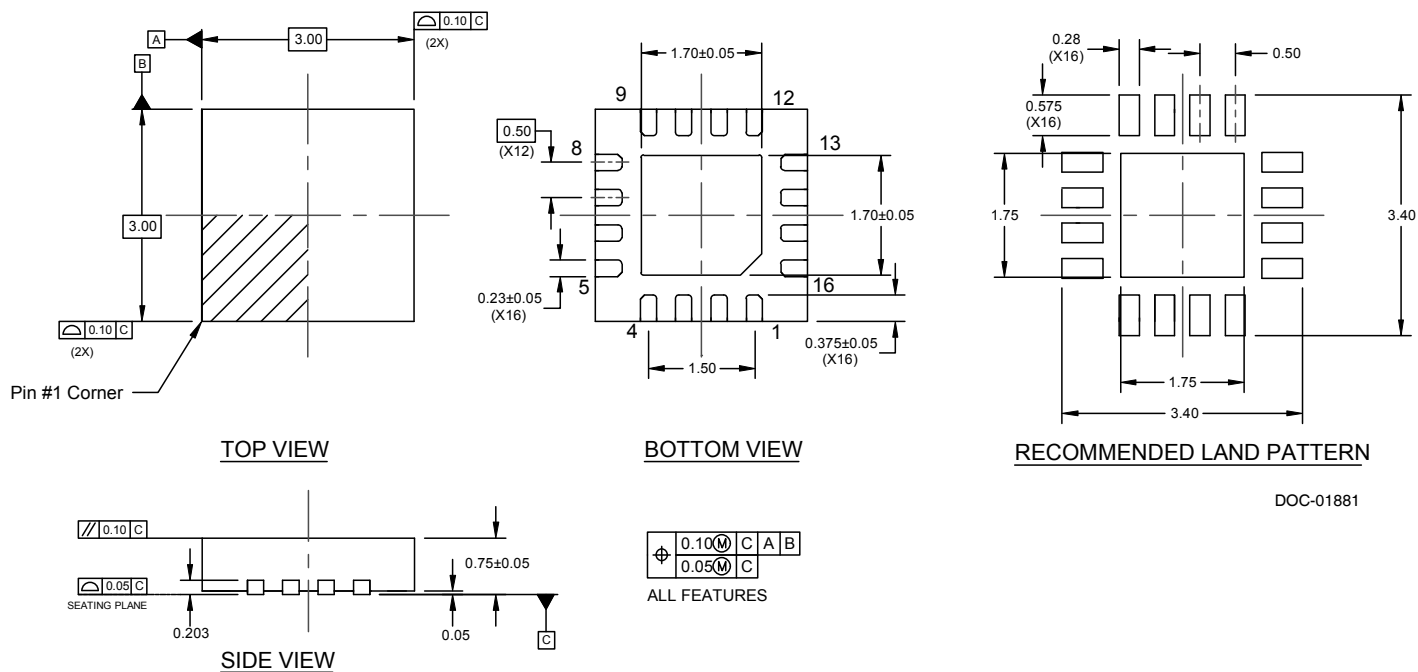


**Figure 13. Evaluation Board Schematic**

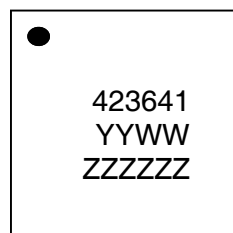


Caution: Contains parts and assemblies susceptible to damage by electrostatic discharge (ESD).

**Figure 14. Package Drawing**  
16-lead 3x3 mm QFN



**Figure 15. Top Marking Specification**



- = Pin 1 designator
- YYWW = Date code, last two digits of the year and work week
- ZZZZZZ = Last six characters of the assembly lot code

DOC-51207