

## Evaluation Kit

### APPLICABLE PARTS (SOLD SEPARATELY)

- PA15FL
- PA341DW
- PA441DW Pin-Outs

### INTRODUCTION

Fast, easy breadboarding of circuits using the PA341DW and PA441DW and the PA15 are possible with the EK42 PC board. Mounting holes are provided and the provision for standard banana jacks simplifies connection and testing. The amplifier may be mounted horizontally or vertically components are labeled on both sides of the board for ease in probing.

Figure 1: PCB Board

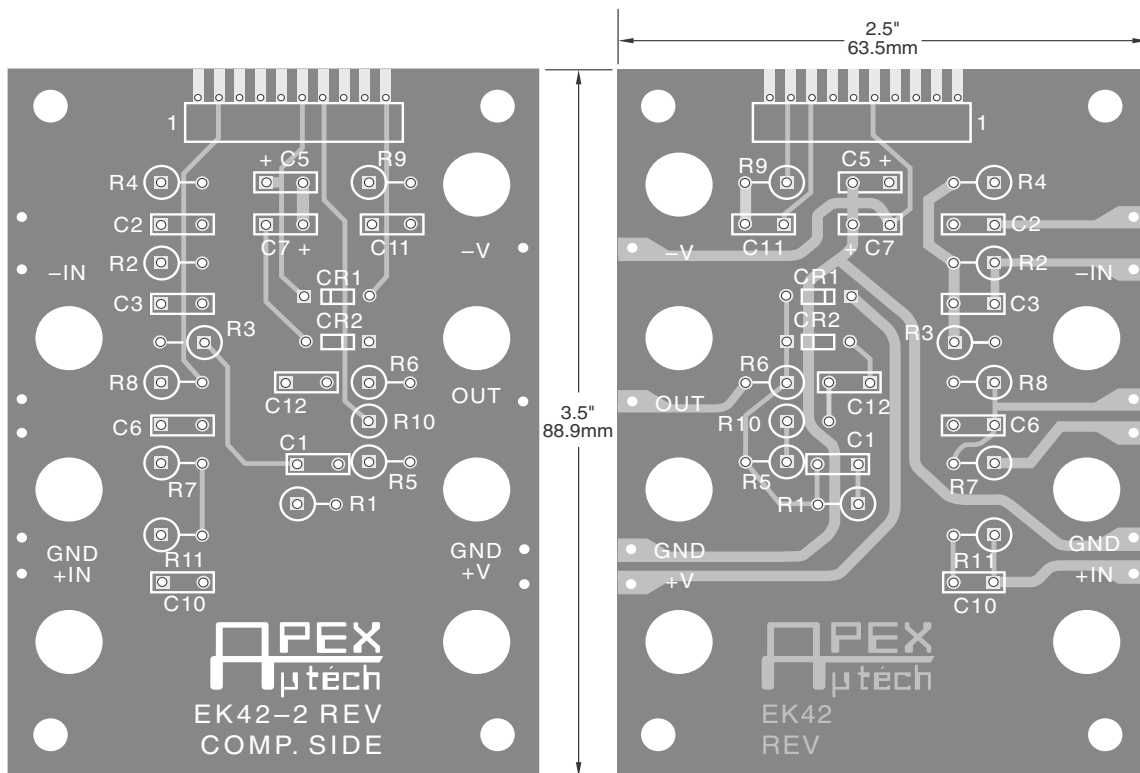

NOTE: Illustration only, not to exact scale

EVALUATION KIT SCHEMATIC AND BOM

Figure 2: EK Schematic

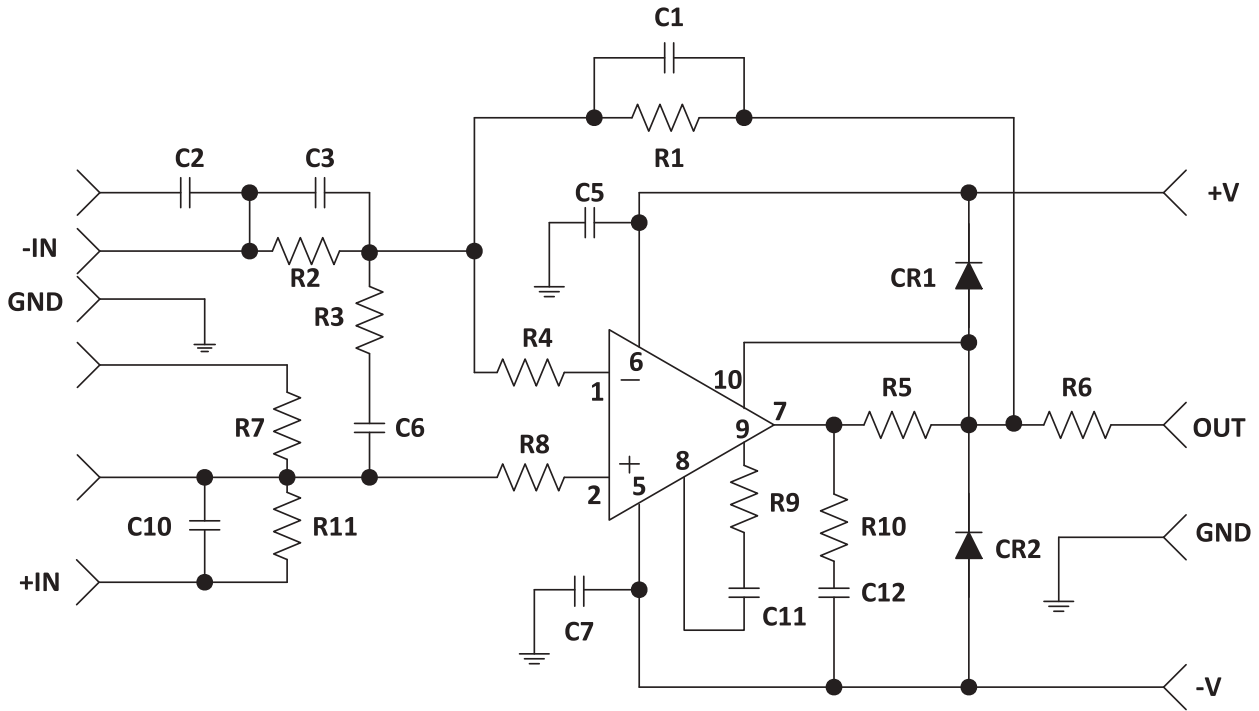

**CAUTION**

High voltages will be present. Use Caution in handling and probing when power is applied.