

Evaluation Kit

APPLICABLE PARTS (SOLD SEPARATELY)

- MP108FD
- MP111FD
- MP118FD (See EK57 - Addendum)

INTRODUCTION

This easy-to-use kit provides a platform for the evaluation of linear power amplifiers circuits using the MP108FD & MP111FD pin out. With ample bread boarding areas it is flexible enough to analyze a multitude of standard or proprietary circuit configurations. Critical connections for power supply bypassing are pre-wired. Components not usually readily available in engineering labs are provided. External connection to the evaluation kit can be made via the terminal block and terminal pads at the edges of the circuit board. The terminal pads are suitable for soldering standard banana jacks or direct soldering of wires. Additionally, banana jacks and a BNC connector can be inserted into the holes at the edge of the board and wired to the numbered terminal pads.

Figure 1: Schematic Diagram

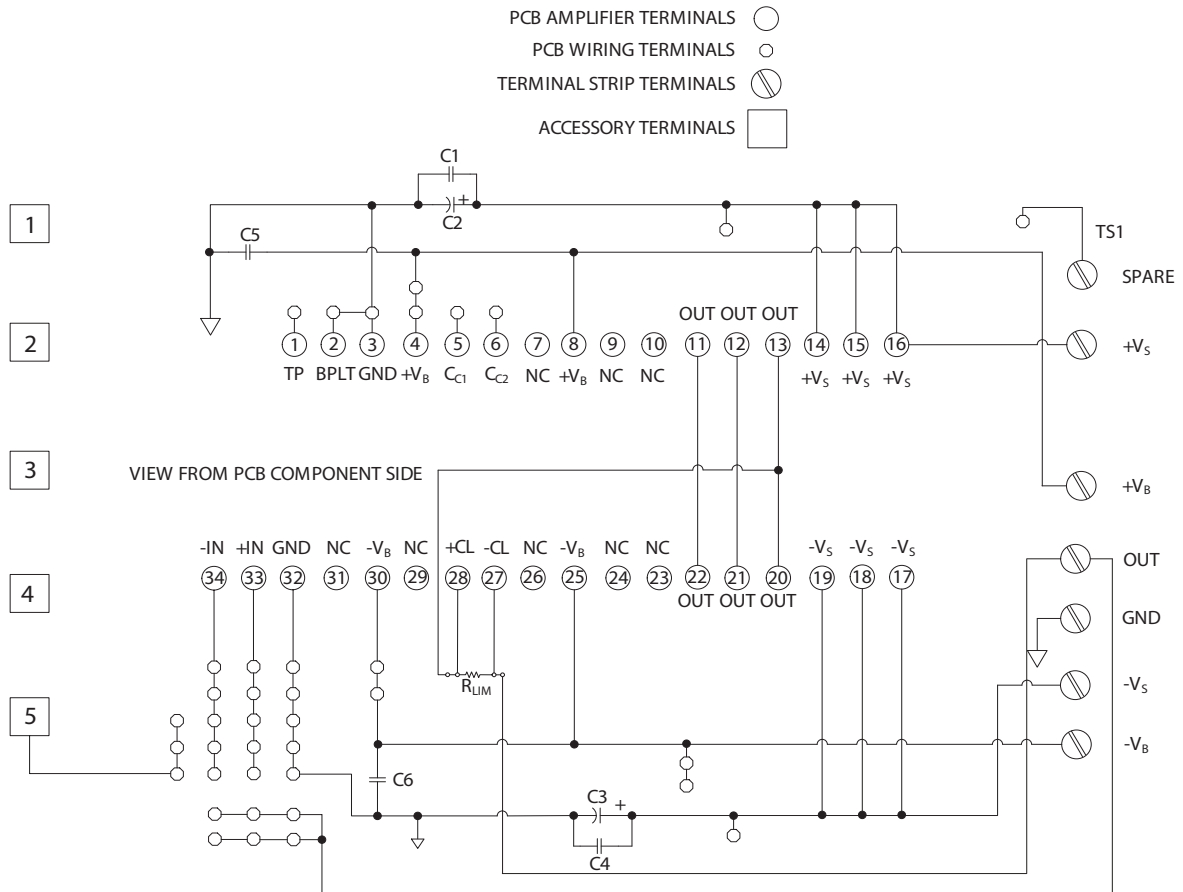
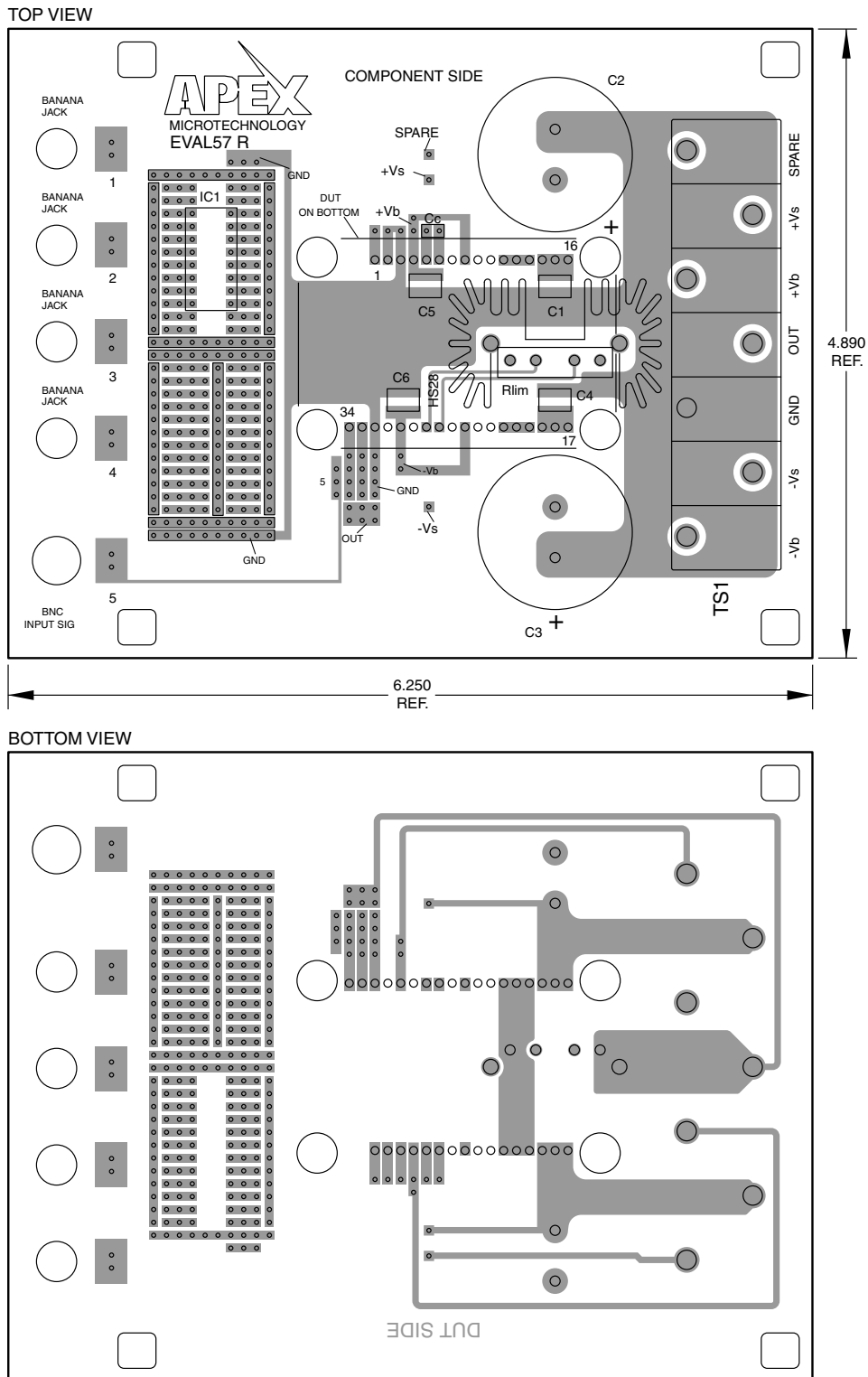

Figure 2: PCB



PARTS LIST

Reference	Manufacturer Part #	Description	QTY
	HS28	Heat Sink	1
	HS31	Heat Sink	1
	S703-93-130-47-052100	Strip of 30 cage jacks	2
	EVAL57	PC Board	1
	60SPG00004	Spacer Grommets/ Micro Plastics	4
C1,4,5,6	1825B105K201N	Cap, 1uF, 200V, 10%-R	4
TS1	TS02	Terminal Strip	1
C2,3	KMH200VN681M25MX40T2	680uF 200V/ United Chemi-Con	2
RLIM*	PBV-R050-1	0.050 Ω Resistor	1
RLIM*	PBV-R100-1	0.100 Ω Resistor	1

*Chosen per directions.

BEFORE YOU GET STARTED

- All Apex Microtechnology amplifiers should be handled using proper ESD precautions.
- Do not change connections while the circuit is powered.
- Initially set all power supplies to the minimum operating voltage allowed in the device data sheet.
- For instructions adapting EK57 for MP118 see EK57 addendum.
- Always use the heatsink provided in this kit and proper power supply bypassing.
- Please refer to the Application Note, AN01, for general operating considerations.

ASSEMBLY

During assembly refer to Figure 2 and the data sheet for the product being evaluated.

1. Note that each side of the circuit board is identified as either the “component side” or “DUT side”.
2. Cut the MS11 into groups of 16 and 18 cage jacks and insert from the “DUT side” of the board. On the “component side” of the board, solder all cage jacks having solder pads (7, 9, 10, 23, 24, 26, 29, and 31 have no solder pads). Make sure the cage jacks are fully seated before soldering. Be careful that solder does not flow into the cage jacks.
3. Pull out the plastic carrier strip from the soldered cage jacks. Without this step, the amplifier will not properly seat! The unsoldered cage jacks will be removed with the carrier strip.
4. Solder the surface mount capacitors at C1, C4, C5, and C6 on the “component side” of the board.
5. Low ohm value resistors are provided with this evaluation kit: 0.050 ohm and 0.100 ohm. These are used to implement current limiting in the output circuit. Select the value most appropriate for your application. Refer to the product data sheet to determine which resistor value you should use.
6. Mount the HS28 heat sink to the PCB and solder the mounting posts of the heat sink.
7. Apply a thin layer of thermal grease on the back of the chosen current limiting sense resistor, insert the resistor into the PCB and mount the resistor to the HS28 heat sink using #4 screw and nut hardware (not supplied). Be sure to cut off the excess resistor lead lengths.
8. Mount the electrolytic capacitors at C2 and C3 from the “component side” of the PCB. Match the polarity markings on the capacitor with the polarity markings on the PCB. Be sure the capacitors have snapped into the PCB and solder from the “DUT side” of the PCB. Be sure to fill the holes with solder.
9. Mount the terminal strip to the “component side” of the PCB. Make sure the terminal strip is fully seated, and solder the pins from the “DUT side” of the PCB. Be sure to fill the mounting holes with solder.

10. Mount and wire the banana jacks and BNC connector (neither supplied) to the PCB pads at locations 1-5 as needed or desired.
11. Mount other components to complete your application circuit using the pads and holes provided.
12. From the “DUT side” of the PCB snap the spacer- grommets into the holes at the four corners of the PCB. Notice that the holes are slightly rectangular. Match the spacer-grommet's long and short sides to the holes in the PCB.
13. Apply a thin, uniform layer of thermal grease to the amplifier; a straight edge may be useful here. Position the amplifier over the mounting holes in the heatsink. Firmly push the amplifier onto the heatsink while slightly rotating the amplifier back and forth, ending with the mounting holes of the amplifier over the mounting holes in the heatsink.
14. Attach the amplifier to the heatsink with 4-40x½' male-female hex spacers (not supplied). These spacers serve as alignment pins and aide in the assembly of the PCB to the heatsink. Alternatively, use 4-40x¼' machine screws to mount the amplifier to the heatsink. Do not over-tighten the spacers or screws as this provides no thermal benefit and may break the hardware.
15. Place the PCB assembly on the heatsink/amplifier assembly so that the hex spacers come through the aligning holes near the corners of the amplifier location in the PCB. Carefully lower the PCB assembly until the pins of the amplifier engage the cage jacks. Alternatively, sight through the aligning holes in the PCB and match-up the PCB to the screws used to mount the amplifier. In either case be sure the pins of the amplifier are engaged with the cage jacks, and then continue pushing the PCB Assembly in the area between the amplifier's pins until the four spacer grommets at the four corners of the PCB touch the heatsink. At this point the PCB should not be bowed.
16. Use #8 X 1" sheet metal screws (not provided) to mount the PCB to the heat sink at the four spacer-grommets.
17. Inspect the assembly from the side and check that the PCB is not bowed toward the heat sink. If the PCB is bowed use a small tool to carefully pry the PCB away from the heat sink until the PCB is flat.
18. Hook up power and signals as necessary. The amplifier is now ready for testing.