

Evaluation Kit

APPLICABLE PARTS (SOLD SEPARATELY)

- PA194

INTRODUCTION

This easy to use kit provides a platform with good circuit board layout and grounding to evaluate PA194 Power Amplifier. The evaluation board provides options to install a load capacitor and series resistor to evaluate the PA194 for a piezo load. All necessary components are provided with the kit. External connections to the evaluation kit can be made through the connectors at the edges of the circuit. The circuit provides a line termination of 50Ω.

Figure 1: Circuit Configuration Diagram

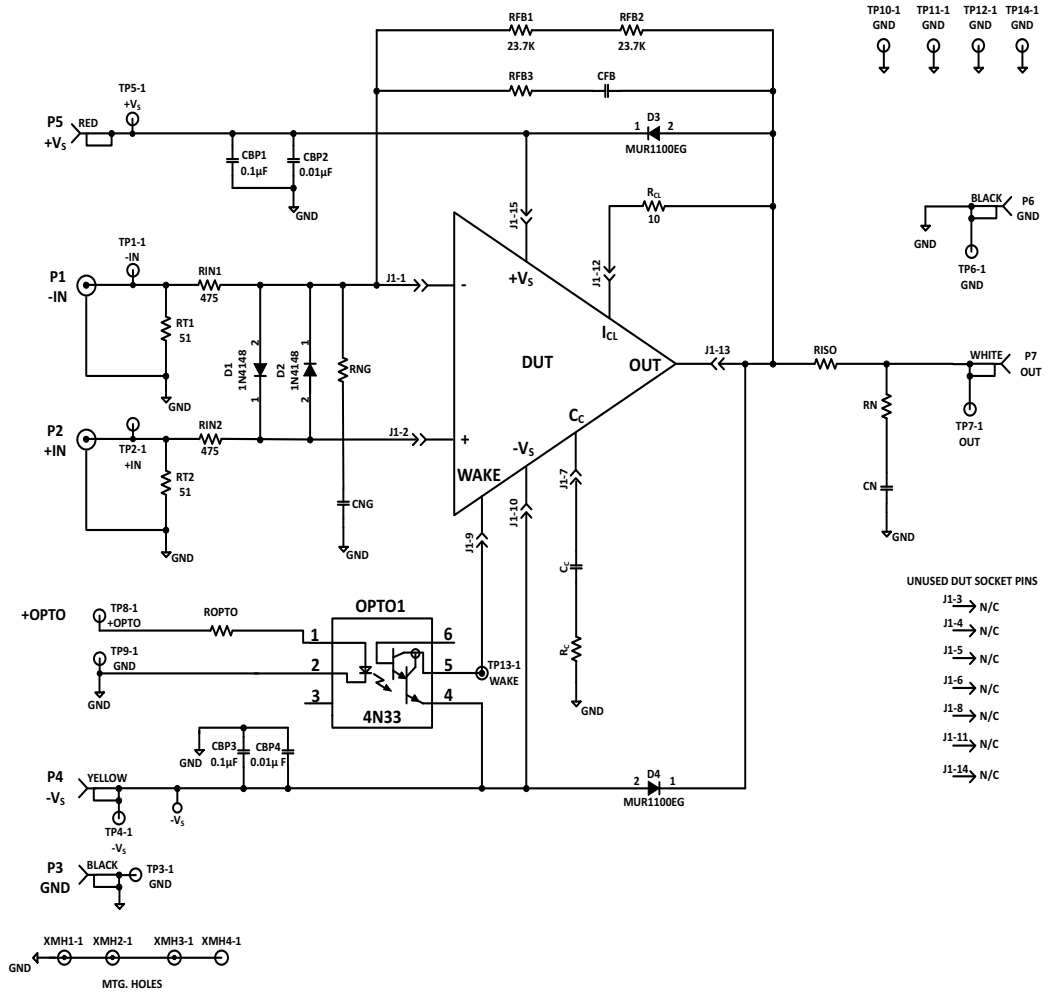

PARTS LIST

| Reference | Manufacturer Part # | Description | QTY |
|-------------------------------------|-------------------------|-------------------------|-----|
| <u>Resistors</u> | | | |
| RT1, RT2 | PR03000205109JAC00 | 51Ω, 3W,5% | 2 |
| RIN1, RIN2 | SFR16S0004750FR500 | 475Ω,1/2W, 1% | 2 |
| RFB1, RFB2 | CMF5523K700FHEB | 23.7kΩ, 1/2W, 1% | 2 |
| R _{LIM} | ERG-1SJ120V | 12Ω, 1W, 5% | 1 |
| ROPTO | CMF554K7500FHEB | 4.75kΩ, 1/2W, 1% | 1 |
| <u>Printed Circuit Board</u> | | | |
| EVAL42 | EVAL42 | Printed Circuit Board | 1 |
| <u>Capacitors</u> | | | |
| CBP2, CBP4 | RDER73A103K3M1H03A | Ceramic, 0.01μF, 1kV | 2 |
| CBP1, CBP3 | RDER73A104K5B1H03B | Ceramic, 0.1μF, 1kV | 2 |
| <u>Diodes</u> | | | |
| D1, D2 | 1N4148 | Diode, Gen. Purpose | 2 |
| D3, D4 | MUR1100EG | Rectifier, Ultra-fast | 2 |
| <u>Hardware</u> | | | |
| | 146510CJ | BNC Connector, pc mount | 2 |
| | 571-0100 | Banana Jacks, pc mount | 5 |
| | 91735A190 | Screw, Panhead, #8 | 4 |
| | 92005A218 | Screw, Panhead, M4 | 2 |
| | 2221 | Standoff, hex, #8 | 4 |
| | Clamp05 | Clamp for Heatsink | 2 |
| | 8637-0-15-15-21-27-10-0 | Cage Jacks | 15 |
| | 5001 | Test Point, pc mini | 10 |
| | TW15 | Thermal Washer | 1 |
| | HS32 | Heat Sink | 1 |
| <u>Miscellaneous</u> | | | |
| OPTO1 | 4N33 | Optocoupler | 1 |

BEFORE YOU GET STARTED

- All Apex Microtechnology amplifiers should be handled using proper ESD precautions.
- Always use the heat sink included in this kit.
- Always use adequate power supply bypassing.
- Do not change the connections while the circuit is powered.
- Initially set all power supplies to the minimum operations levels allowed in the device data sheet.
- Check for oscillations.
- Please refer to Application Note, AN01 for general operating conditions.

ASSEMBLY INSTRUCTIONS

During the assembly, please refer to the circuit schematics, assembly drawings, and the datasheet of the part being used on the evaluation kit.

1. All through hole components (including the cage jacks) are installed on the component side of the board and soldered on the bottom side.
2. Insert the cage jacks on the DUT side of the board. Once they are inserted, solder the cage jacks from the bottom side of the board.
3. Install all small through hole components like capacitors, resistors, and test points on the component side of the board. This is done because it becomes difficult to install a smaller part on the board once all the larger components are installed.
4. Install diodes D1, D2, D3, and D4 on the component side of the board. Ensure that the orientation of the components match the circuit schematic drawing.
5. Do not use a compensation capacitor for a gain of 100. Input resistors and Feedback resistors are provided for a gain of 100. In this case, leave C_C pin open. Also, do not use RNG and CNG components.
6. If the amplifier is being evaluated for a gain of 20 or less, use the compensation capacitor (C_C) and compensation resistor (R_C) as shown in the schematic. Please refer to the PA194 datasheet for C_C values for different gain settings. In case R_C is not being used, connect the compensation capacitor to ground.
7. Mount the BNC connectors provided with the kit (146510CJ) and solder it to the board. Also mount the banana jacks on the board. Install other miscellaneous components like optocoupler and bus wires.
8. From the DUT side of the PCB, insert #8 panhead screws into the holes at the four corners of the PCB. Connect the hexagonal standoffs from the bottom side of the board.
9. Next, mount the amplifier on the heatsink using the two clamps provided with the kit. Insert the TW15 thermal washer between the heatsink and the amplifier.
10. Once the PA194 is mounted on the heatsink, insert the assembly on the PCB. Make sure the amplifier is inserted into the cage jacks and the heatsink is aligned on the holes provided on the edges of the PCB.
11. Use M4 screws to mount the heatsink on the PCB. This ensures that the heatsink does not move.
12. Make sure that the heat tab is grounded.
13. Connect the external connections via the BNC connector and banana jacks. Hook up power supplies and signals as necessary. The amplifier is now ready for evaluation.

Figure 2: Top Assembly

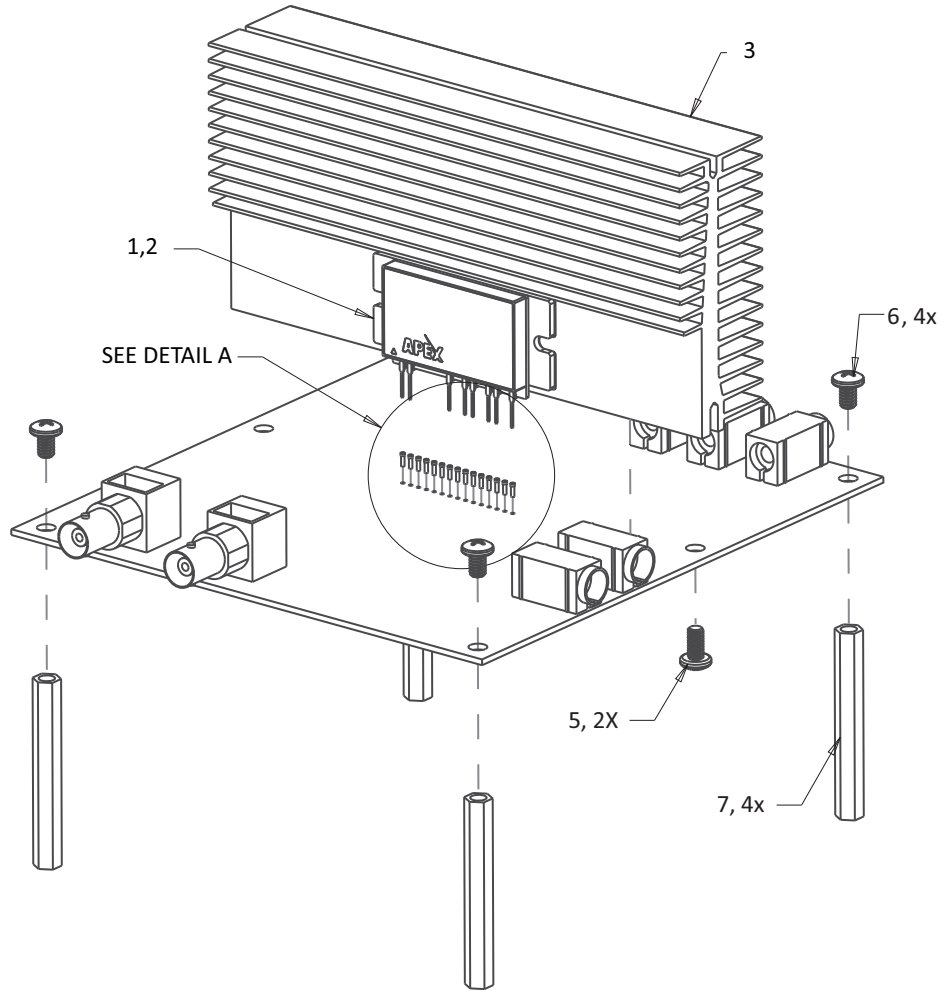

DETAIL A

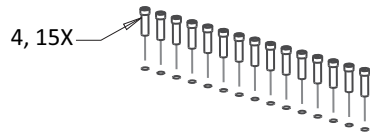

- 1. 1 X PA194
- 2. 1 X TW15 Thermal Washer
- 3. 1 X HS32 Heatsink
- 4. 15 X Cage Jacks
- 5. 2 X M4 Screws
- 6. 4 X #8 Panhead Screws
- 7. 4 X #8 Hex Standoffs

Figure 3: Bottom Assembly

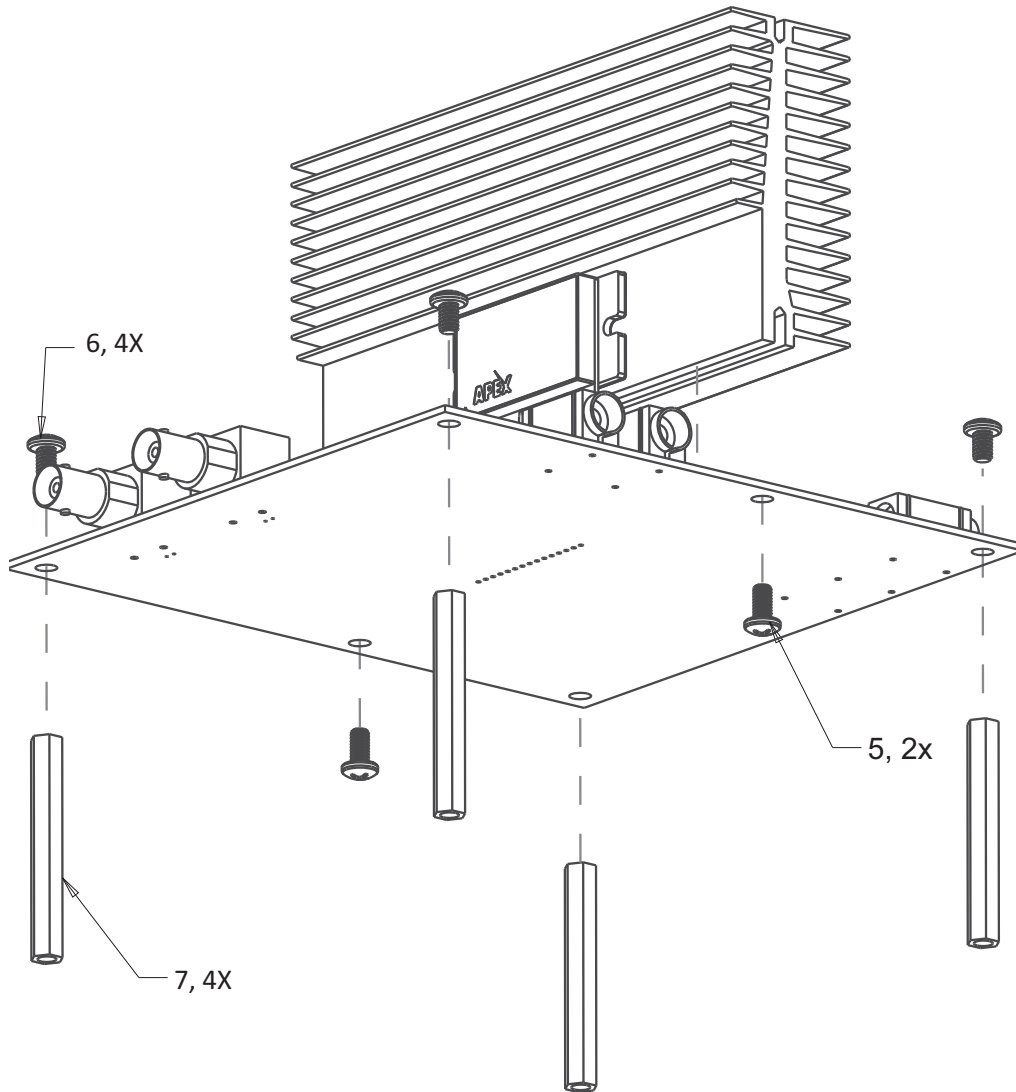

TEST ASSEMBLY

EQUIPMENT NEEDED

1. Power Supply
2. Function Generator
3. Oscilloscope
4. Heatsink

TEST SETUP

Connect the power supply to $+V_S$ and $-V_S$ ports. Refer to product datasheet for voltage specifications. Connect the BNC cable from the function generator to either P1 port for inverting configuration or to P2 for non-inverting configuration. Connect a 5V DC supply to TP8 port for the optocoupler.

Do not insert the part yet. Next, power on the input signal and power supplies. Measure voltages on all pins on the DUT side to ensure that there is not short and to check that all the pins read correct voltages.

Next, mount the amplifier + Heatsink assembly on the PC board. If connecting a resistor load, do not mount anything for the snubber circuit (RN and CN). Short RISO with a bus wire. If a piezo load is connected, connect a resistor for RISO and connect RN and CN components for the snubber circuit. Calculate the values of the snubber circuit for the proper corner frequency. Input and output waveforms can be checked on an Oscilloscope by connecting it to the test points mounted on the board. Begin the test with minimum values of input and supply voltages.

Figure 4 shows a typical output waveform of the PA194 using the EK66 Evaluation Kit. The yellow waveform is the input pulse signal to the amplifier, while the blue waveform shows the output waveform.

Figure 4: Output Waveform

