

Evaluation Kit

APPLICABLE PARTS (SOLD SEPARATELY)

- PA107

INTRODUCTION

The EK71 Evaluation kit is designed to provide a convenient way to breadboard and evaluate design ideas for the PA107 power operational amplifier. The evaluation board is pre-wired for all required external components. The evaluation board has been laid out and labeled to easily configure the high voltage operational amplifier in an inverting configuration. However, the evaluation board is flexible enough to analyze a multitude of standard or proprietary circuit configurations. Components not usually readily available in engineering labs are provided. External connection to the evaluation kit can be made via the terminal connectors at the edge of the circuit board. These connectors are suitable for standard banana plugs. The schematic is shown in Figure 1.

Figure 1: EK71 Schematic

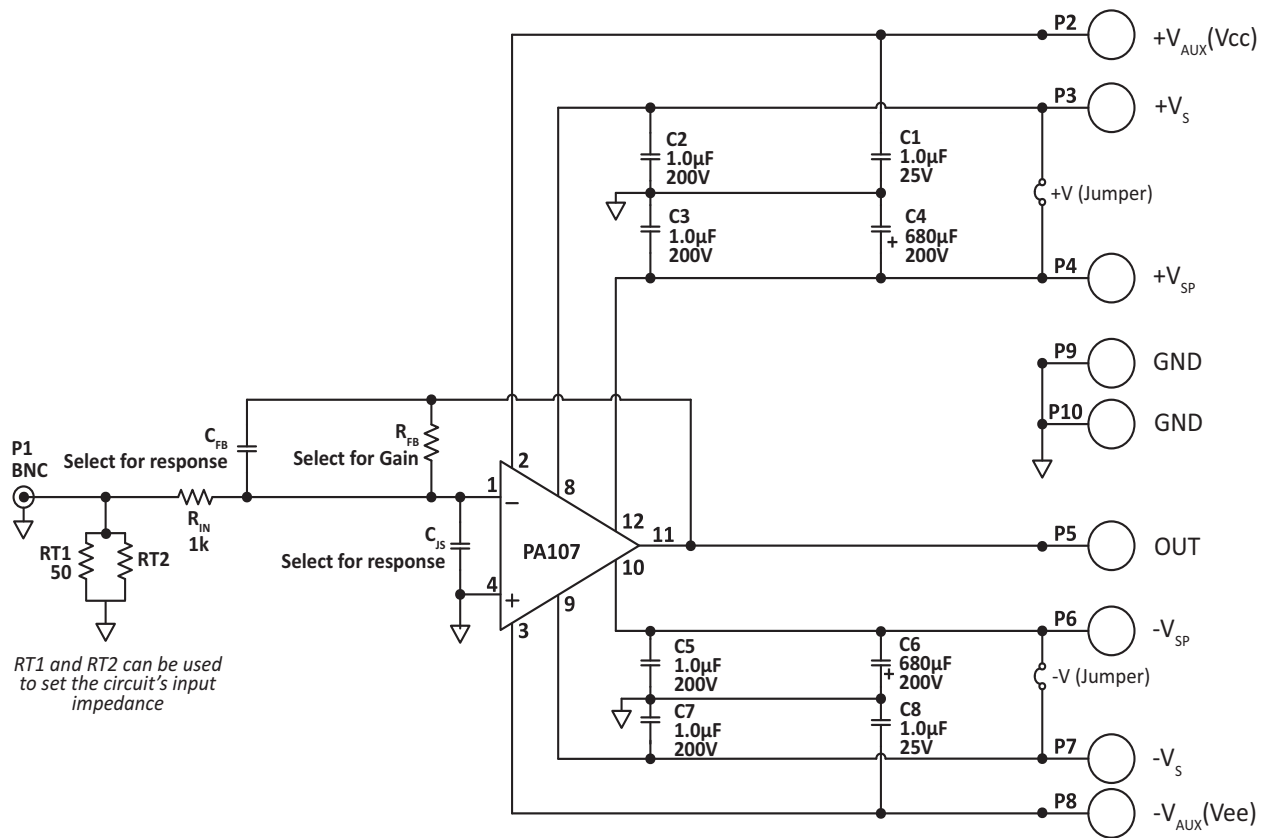

PARTS LIST

Reference	Manufacturer Part #	Description	QTY
P1	146510CJ	Connector, BNC, PCB Mount	1
P2, P3, P4, P5, P6, P7, P8	571-0100	4mm Black PCB Socket Single	9
C ₄ , C ₆	KMH200VN68IM25X40T2	Capacitor, 680 μ F	2
	EVAL71	PC Board	1
	HS20	Heatsink	1
	310-43-120-41-001000	Mating Socket	1
C ₂ , C ₇ , C ₅ , C ₃	OX7R105KWN	Cap, 1 μ F	4
	TW07	Thermal Washer, PSIP	1

BEFORE YOU GET STARTED

- Please read this data sheet in its entirety before starting to construct your evaluation board.
- All Apex Microtechnology amplifiers should be handled using proper ESD precautions.
- Do not change connections while the circuit is powered.
- Initially set all power supplies to the minimum operating voltage allowed in the device data sheet.
- Always use adequate power supply bypass capacitors, Apex Microtechnology recommends 1 μ F (ceramic) in parallel with at least 10 μ F per ampere of output current (electrolytic/tantalum).
- Always provide the adequate heat sinking. Power dissipation must be considered to ensure maximum junction temperature is not exceeded.
- Check for oscillations.
- Please refer to Application Note, AN01 for general operating considerations.

ASSEMBLY

1. See Figure 1 and Figure 2. Solder the surface mount ceramic capacitors to the DUT side of the circuit board at C2, C7, C5 and C3.
2. Clip off the mating socket strip after the 12th position. Insert the strip into the circuit board from the DUT side and solder one pin on the reverse side. Check that the mating socket strip is fully seated against the circuit board then solder the remaining pins. Insert the amplifier fully into the mating socket strip, noting the pin 1 locations on the amplifier and the circuit board.
3. To select the values of feedback resistor (RFB), feedback capacitor (CFB) and summing junction capacitor (CSJ), please refer to the section titled "FEEDBACK CONSIDERATIONS" in the PA107DP data sheet.
4. C1 and C8 are user supplied pin-through-hole bypass capacitors for Vcc and Vee respectively. Insert C1 and C8 from the component side and solder from the circuit side.
5. Add other components as necessary to complete your application circuit.
6. Solder the electrolytic capacitors to the circuit board at C4 and C6. Match the polarity markings on the circuit board with those on the capacitor body.
7. Examine the large heat sink. Notice that there are several holes in the face of the heat sink. These are for mounting various Apex Microtechnology amplifier models. The circuit board aligns the amplifier with the correct mounting hole once the heat sink is attached to the circuit board.
8. The four holes at the corners of the circuit board are for mounting #6 standoff spacers if desired. The remaining two slotted holes are for mounting the large heat sink to the DUT side of the circuit board. Temporarily mount the heat sink with 2 #6 x 1/2" [3 x 15mm] self tapping screws from the opposite side of the circuit board. Do not fully tighten the screws at this time. Check for alignment of the slot in the

mounting tab of the amplifier with a hole in the heat sink. Dismount and rotate the heat sink if necessary to achieve an alignment with a hole in the heat sink. Position the heat sink so that the back of the amplifier mounting tab is flush with the heat sink then tighten the heat sink mounting screws.

9. Hang the thermal washer near the end of a 6-32 x 1/2" [M4 X 15mm] screw. Slightly pull the amplifier away from the heat sink face. Use the screw to position the thermal washer behind the amplifier and insert the screw into the mounting hole of the heat sink. Secure the screw from the opposite side of the heat sink using a nut holder.

Figure 2: EK71 Assembly



Figure 3: EVAL71 PCB Layout

