

## Evaluation Kit

### APPLICABLE PARTS (SOLD SEPARATELY)

- MP206KP

### INTRODUCTION

This kit provides a quick-and-easy platform for evaluations of the MP206 dual-channel power amplifier. The evaluation kit includes an external connector that attaches various loads, such as sample capacitive networks or the analog portion of industrial drop-on-demand print heads. All necessary components are included with the kit. Input signals and power supply voltages are user-selectable and must be supplied externally. Inverting and non-inverting circuits can both be configured on this board.

Figure 1: Circuit Diagram

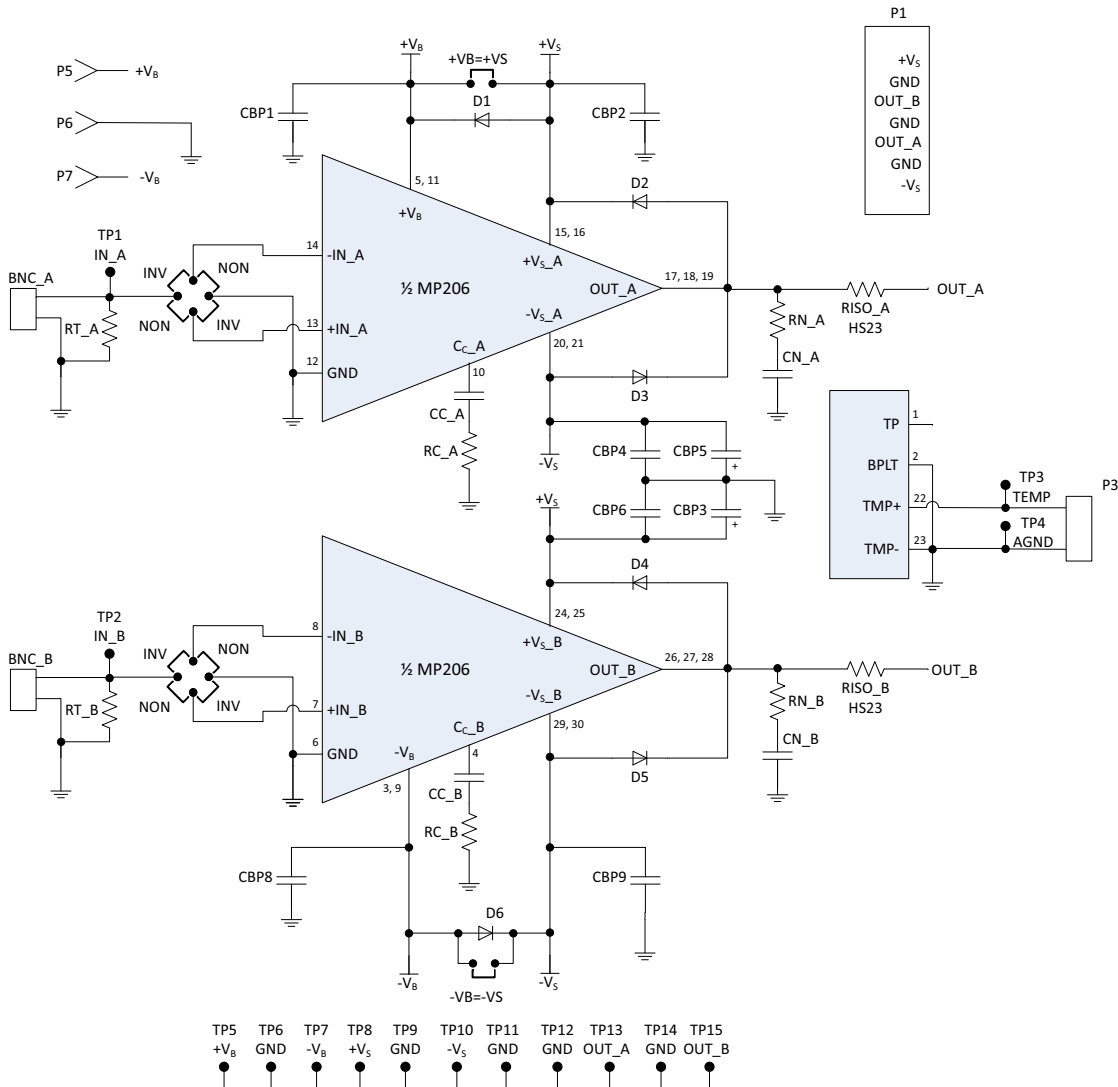
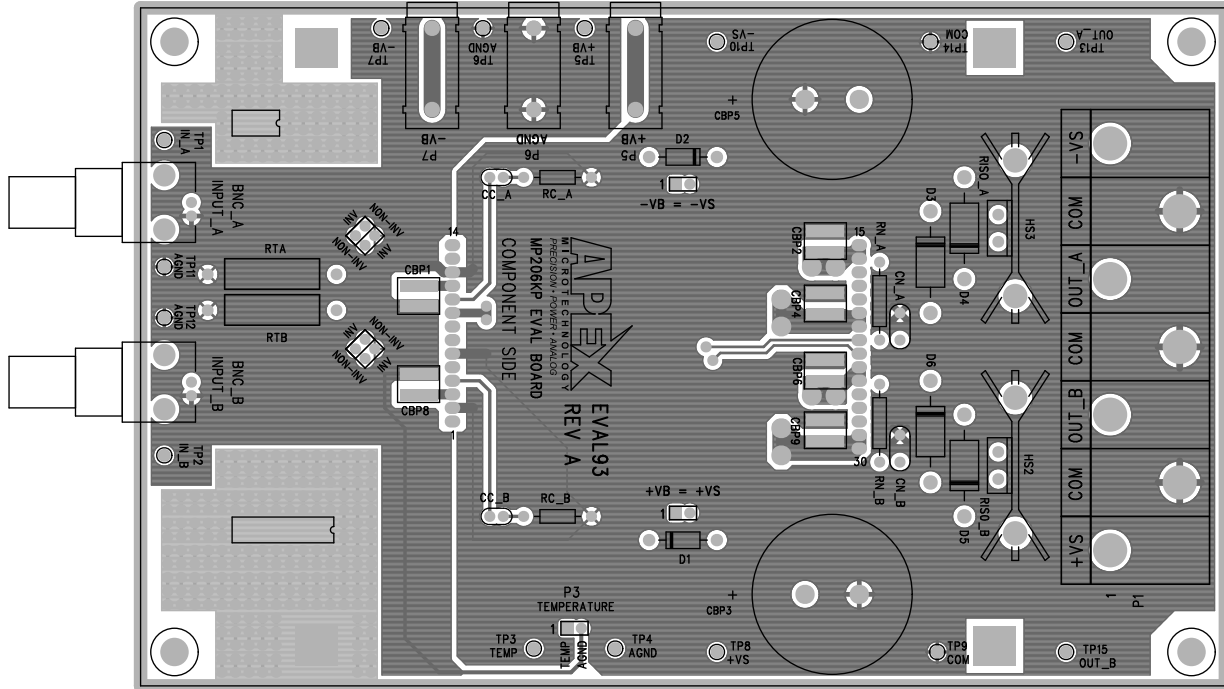

Figure 2: Board Layout



**PARTS LIST**

Reference	Manufacturer Part #	Description	QTY
<b><u>Printed Circuit Board</u></b>			
EVAL93	EVAL93	Printed Circuit Board	1
<b><u>Resistors</u></b>			
RC_A, RC_B	CF14JT750R	750Ω, 1/4W, 5%	2
RN_A, RN_B	RS01A5R000FE70	5Ω, 1W, 1%	2
RISO_A, RISO_B	PF2203-0R2F1	0.2Ω, 35W, 1%, TO-220	2
RT_A, RT_B	PR03000205109JAC00	51Ω, 3W, 5%	2
<b><u>Capacitors</u></b>			
CBP1, 2, 4, 6, 8, 9 *	OX7RR105KWN	Ceramic, 1μF, 250V, X7R	4
CBP3, 5 *	EC05	Electrolytic, 2200μF, 100V	1
CC_A, CC_B	SR151A151JAR	Ceramic, 150pF, 100V, COG	2
CN_A, CN_B	C322C223K1R5TA	Ceramic, 22nF, 100C, X7R	2
<b><u>Hardware</u></b>			
BNC_A, BNC_B	146510CJ	BNC connector, PC Mount	2
P1	TS02	7-Block Terminal Strip	1
P5, 6, 7	571-0100	Banana Jack, PC Mount	3
	MS11	Cage Jacks, 30-Strip	1
	HS31	Heatsink, DUT	1
	HS23	Heatsink, RISO	2
	60SPG00004	Spacer Grommets	4
	94997A350	M3.5 Sheet Metal Screw	4
	91772A106	#4-40 1/4" Panhead Screw	6
	91841A005	#4-40 Hex Nut	2
<b><u>Miscellaneous</u></b>			
TP1 - 15	5001	Test Point, PC Mini	15
	PRPC002SAAN-RC	Pin Header, 1x2	7
	SPC02SVJN-RC	Jumper, Slip-On	6

\*Not all designated components are supplied. See Assembly Instructions for important details.

## BEFORE YOU GET STARTED

- All Apex Microtechnology amplifiers should be handled using proper ESD precautions.
- Always use the heat sink included in this kit.
- Always use adequate power supply bypassing.
- Do not change the connections while the circuit is powered.
- Initially set all power supplies to the minimum operations levels allowed in the device data sheet.
- Check for oscillations.
- Please refer to Application Note, AN01 for general operating conditions.

## ASSEMBLY INSTRUCTIONS

During the assembly, please refer to the circuit schematics, assembly drawings, and the data sheet of the part being used on the evaluation kit.

1. Note that each side of the circuit board is identified as either the component side or the DUT (Device Under Test) side. The component side has the designators printed on that side.
2. All through hole components (except the cage jacks) are installed on the component side of the board and soldered on the DUT side.
3. 30 cage jacks are supplied with this evaluation kit on a single carrier strip. Break it into two strips of 14 and 16 jacks. Insert the carrier strips through the DUT side and solder the cage jacks on the component side. Ensure that solder only flows around the outside of each cage jack. **IMPORTANT: Once the cage jacks are soldered, remove the carrier strip, leaving only cage jacks soldered on the board. IF THE CARRIER STRIP IS NOT REMOVED, THE BOARD WILL NOT MAKE PROPER CONTACT WITH THE DUT.**
4. Ceramic Bypass: Application Dependent:
  - For Non-Inverting Circuits (Xaar 5601):  
Install CBP1, CBP2, CBP6, and CBP8 on the component side of the board, using the supplied ceramic surface mount capacitors. Do not install CBP4 or CBP9.
  - For Inverting Circuits (Fujifilm Dimatix Samba or GMA series):  
Install CBP1, CBP4, CBP8, and CBP9 on the component side of the board, using the supplied ceramic surface mount capacitors. Do not install CBP2 or CBP6.
5. Install diodes D1 through D6 on the component side of the board. Ensure that the orientation of the components match the circuit schematic drawing.
6. Next install all the smaller components on the board. This is done because it becomes difficult to install a smaller part on the board once all the larger components are installed.
7. Electrolytic Bypass: Application Dependent:
  - For Non-Inverting Circuits (Xaar 5601):  
Install CBP3, ensuring that the orientation matches the circuit schematic drawing. Use a piece of heavy wire (16 to 14 AWG, 1.3 to 1.8mm) to short CBP5. This will connect  $-V_S$  to ground. Hint: use the clippings from MUR420G.
  - For Inverting Circuits (Fujifilm Dimatix Samba or GMA series):  
Install CBP5, ensuring that the orientation matches the circuit schematic drawing. Use a piece of heavy wire (16 to 14 AWG, 1.2 to 1.8mm) to short CBP3. This will connect  $+V_S$  to ground. Hint: use the clippings from MUR420G.
8. Apply a thin, uniform layer of thermal grease to the backside of the RISO resistors. Position the RISO resistors over the lower hole of the HS23 heatsinks. Firmly press the RISO resistors into their heatsinks and mount with one #4-40 screw and nut each. Do not over-tighten. Solder the resistor leads into the board and slightly bend the heatsink tabs to secure the heatsinks

9. Mount the BNC connectors provided with the kit (146510CJ) and solder them to the board. Also mount the banana jacks on the board. Install other miscellaneous components like jumpers and test points to complete your application circuit.
10. From the DUT side of the PCB, snap the spacer-grommets into the holes at the four corners of the PCB. Notice that the holes are slightly rectangular. Match the spacer-grommets long and short sides to the holes in the PCB.
11. Apply a thin, uniform layer of thermal grease to the amplifier; a straight edge may be useful here. Position the amplifier over the mounting holes in the HS31 heatsink. Firmly push the amplifier onto the heatsink while slightly rotating the amplifier back and forth, ending with the mounting holes of the amplifier over the mounting holes in the heatsink.
12. Use #4-40 x ¼" machine screws to mount the amplifier to the heatsink. Do not over-tighten the screws as this provides no thermal benefit and may break the hardware.
13. Carefully lower the PCB assembly until the pins of the amplifier engage the cage jacks and then continue pushing the PCB assembly in the area between the amplifier's pins until the four spacer grommets at the four corners of the PCB touch the heatsink. At this point the PCB should not be bowed.
14. Use M3.5 sheet metal screws to mount the PCB to the heat sink at the four spacer-grommets.

### JUMPER CONFIGURATION INSTRUCTIONS

See the figure below for setting up the inverting/non-inverting configurations.

**Figure 3: Inverting/Non-Inverting Mode Setup**

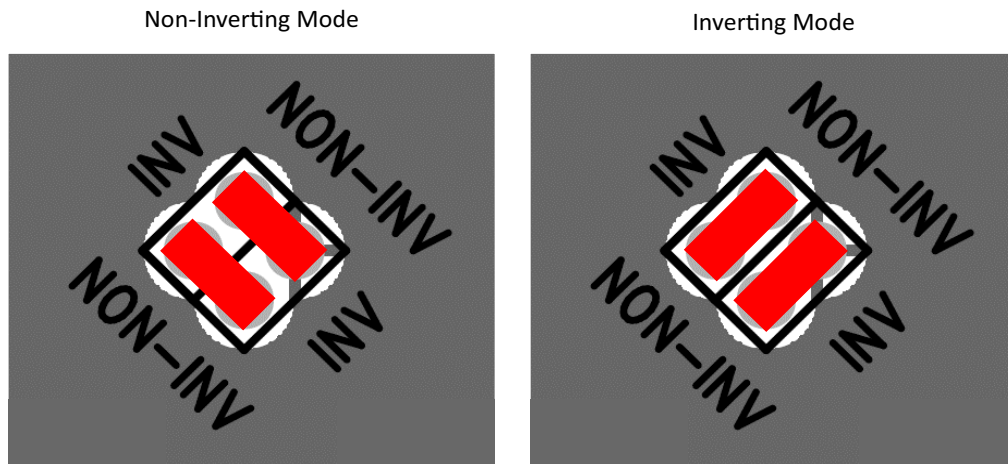

Additionally, one of the “ $\pm V_S = \pm V_B$ ” jumpers may be shorted if a boost supply is not required. See MP206 datasheet for details. For proper operation, only the 4 following configurations are recommended:

	+V <sub>S</sub> = +V <sub>B</sub> jumper	-V <sub>S</sub> = -V <sub>B</sub> jumper	+V <sub>B</sub> voltage (P5)	-V <sub>B</sub> voltage (P7)
INV, no boost	Not shorted	Shorted	18V	Not Connected
NONINV, no boost	Shorted	Not shorted	Not Connected	-18V
INV, boost	Not shorted	Not shorted	18V	See Datasheet
NONINV, boost	Not shorted	Not shorted	See datasheet	-18V

## DUAL SUPPLY OPERATION

For unique applications that require both positive and negative output voltages, additional components will be required. As of the latest publication of this datasheet, the following part numbers are valid:

<u>Manufacturer Part #</u>	<u>Qty</u>	<u>Description</u>	<u>Instruction</u>
SLP222M100C4P3	1	Electrolytic cap, 2200 $\mu$ F, 100V, snap-in	Omit short in step7, install in place of short
GRM55DR72E105KW01L	2	Ceramic cap, 1 $\mu$ F, 250V, size 2220, X7R	Install in omitted designators from step 4

Additionally, only the following configurations are recommended in Dual Supply Operation:

	+V <sub>S</sub> = +V <sub>B</sub> jumper	-V <sub>S</sub> = -V <sub>B</sub> jumper	+V <sub>B</sub> voltage (P5)	-V <sub>B</sub> voltage (P7)
No boost, INV or NONINV	Shorted	Shorted	Not Connected	Not Connected
Boost, INV or NONINV	Not shorted	Not shorted	See Datasheet	See Datasheet

**Figure 4: Top View**

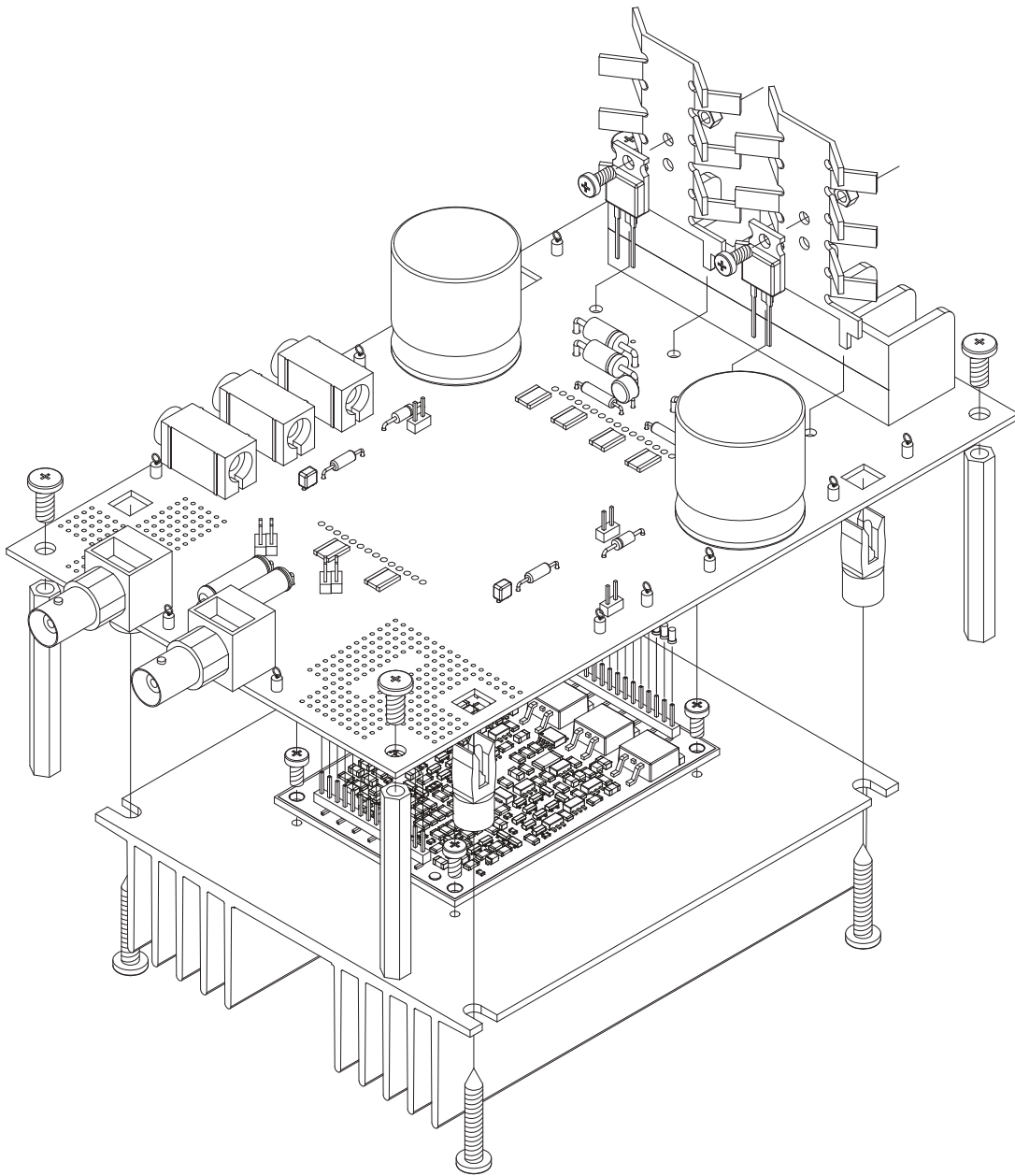

**Note:** Standoffs pictured at each corner are optional and not included with the kit. The board pictured includes all components for inverting and non-inverting modes; only a dual-supply application board will include all of these components.

Figure 5: Bottom View

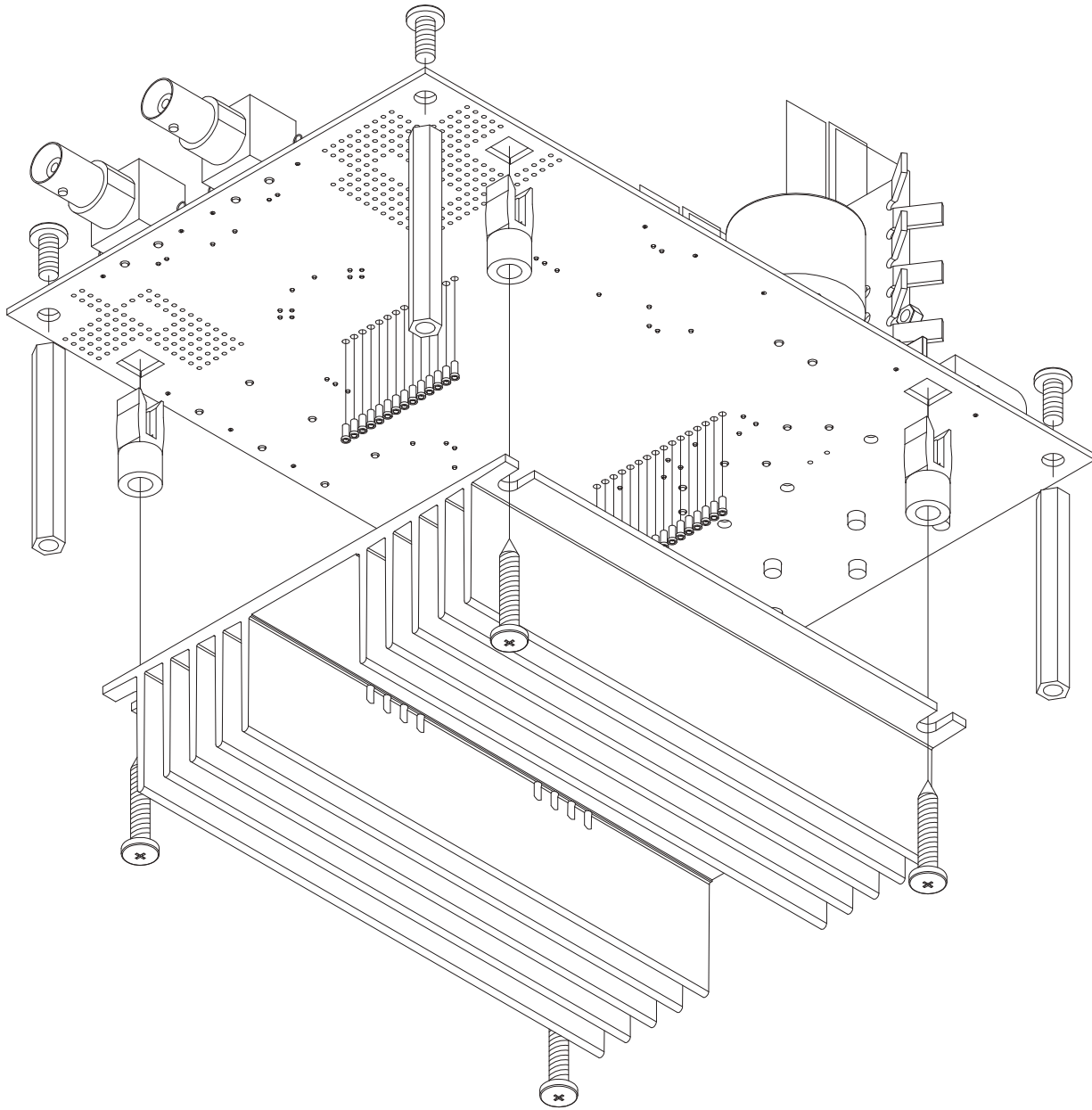



## TEST ASSEMBLY

### EQUIPMENT NEEDED

1. Power Supplies
2. Function Generator
3. Oscilloscope
4. Proper Heatsinking System

### TEST SETUP

Connect the power supplies as specified in the “Jumper Configuration Instructions” table, in addition to the  $V_S$  supply. Make sure all supplies are turned off before connection.

For added precaution, power on the circuit with the amplifier removed. Check the voltage at each cage jack without the DUT, for correct voltage / signal at each respective pin. Once this is done, power down the supplies/signals and reinsert the DUT.

Power supply sequencing should follow that given in the datasheet of MP206. In general, with D1 and D6 installed,  $\pm V_S$  should be turned on first, then  $\pm V_B$ . During power down, turn off  $\pm V_B$  first, then  $\pm V_S$ .

It is recommended to first test the device with no load attached. Ensure the output waveform follows the expected results before connecting a load. Consider power dissipation in the Amplifier, RISO resistors, and the load.

### TEST RESULTS

The following oscilloscope shot pictures the results of an EK75 with MP206 driving a 180nF load in non-inverting configuration.  $+V_S = 50V$ ,  $+V_B = +V_S$ ,  $-V_S = GND$ ,  $-V_B = -18V$ . Ch1 = Input signal, Ch2 = Output signal.

Figure 6: Example Waveform

