

EL5178, EL5378

700MHz Differential Twisted-Pair Drivers

FN7491  
Rev 7.00  
February 4, 2016

The [EL5178](#) and [EL5378](#) are single and triple high bandwidth amplifiers with an output in differential form. They are primarily targeted for applications such as driving twisted-pair lines in component video applications. The inputs can be in either single-ended or differential form but the outputs are always in differential form.

On the EL5178 and EL5378, two feedback inputs provide the user with the ability to set the gain of each device (stable at minimum gain of 2).

The output common mode level for each channel is set by the associated REF pin, which has a -3dB bandwidth of over 110MHz. Generally, these pins are grounded but can be tied to any voltage reference.

All outputs are short-circuit protected to withstand temporary overload condition.

The EL5178 is available in 8 Ld MSOP and SOIC packages and EL5378 is available in a 28 Ld QSOP package. All are specified for operation over the full -40°C to +85°C temperature range.

**Features**

- Fully differential inputs, outputs, and feedback
- Differential input range  $\pm 2.3V$
- 700MHz 3dB bandwidth
- 1000V/ $\mu s$  slew rate
- Low distortion at 5MHz and 20MHz
- Single 5V or dual  $\pm 5V$  supplies
- 60mA maximum output current
- Low power - 12.5mA per channel
- Pb-free (RoHS compliant)

**Applications**

- Twisted-pair driver
- Differential line driver
- VGA over twisted-pair
- ADSL/HDSL driver
- Single-ended to differential amplification
- Transmission of analog signals in a noisy environment

**Pin Configurations**

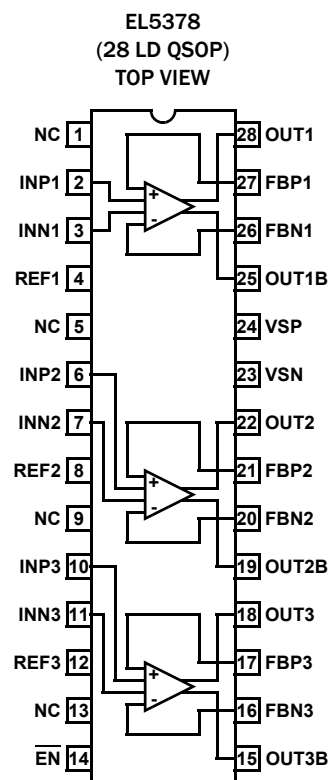
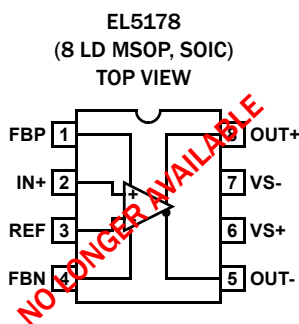

## Pin Descriptions

EL5178 (NO LONGER AVAILABLE)	EL5378	PIN NAME	PIN FUNCTION
	17, 21, 27	FBP3, FBP2, FBP1	Feedback from non-inverting outputs
	2, 6, 10	INP1, INP2, INP3	Non-inverting inputs
	3, 7, 11	INN1, INN2, INN3	Inverting inputs, note that on EL5178, this pin is also the REF pin
	16, 20, 26	FBN3, FBN2, FBN1	Feedback from inverting outputs
	15, 19, 25	OUT3B, OUT2B, OUT1B	Inverting outputs
	24	VSP	Positive supply
	23	VSN	Negative supply
	18, 22, 28	OUT3, OUT2, OUT1	Non-inverting outputs
	1, 5, 9, 13	NC	No connect; grounded for best crosstalk performance
	4, 8, 12	REF1, REF2, REF3	Reference inputs, sets common-mode output voltage
	14	EN	ENABLE
1		FBP	Feedback from non-inverting output
2		IN+	Non-inverting input
3		REF	Inverting input, note that on EL5178, this pin is also the REF pin
4		FBN	Feedback from inverting output
5		OUT-	Inverting output
6		VS+	Positive supply
7		VS-	Negative supply
8		OUT+	Non-inverting output

## Ordering Information

PART NUMBER (Notes 1, 2, 3)	PART MARKING	TEMP RANGE (°C)	PACKAGE (RoHS Compliant)	PKG. DWG. #
EL5178ISZ (No longer available, recommended replacement: EL5174ISZ)	5178ISZ	-40 to +85	8 Ld SOIC (150 mil)	M8.15E
EL5178IYZ (No longer available, recommended replacement: EL5174ISZ)	BBHAA	-40 to +85	8 Ld MSOP (3.0mm)	M8.118A
EL5378IUZ	EL5378IUZ	-40 to +85	28 Ld QSOP (150 mil)	M28.15

### NOTES:

1. Add "-T13" suffix for 2.5k unit or "-T7" suffix for 1k unit Tape and Reel options. Please refer to [TB347](#) for details on reel specifications.
2. These Intersil Pb-free plastic packaged products employ special Pb-free material sets, molding compounds/die attach materials, and 100% matte tin plate plus anneal (e3 termination finish, which is RoHS compliant and compatible with both SnPb and Pb-free soldering operations). Intersil Pb-free products are MSL classified at Pb-free peak reflow temperatures that meet or exceed the Pb-free requirements of IPC/JEDEC J STD-020.
3. For Moisture Sensitivity Level (MSL), please see device information page for [EL5178](#), [EL5378](#). For more information on MSL please see tech brief [TB363](#).

**Absolute Maximum Ratings** ( $T_A = +25^\circ\text{C}$ )

Supply Voltage ( $V_{S+}$ to $V_{S-}$ )	12V
Supply Voltage Rate-of-Rise (dV/dT)	1V/ $\mu\text{s}$
Input Voltage (IN+, IN- to $V_{S+}$ , $V_{S-}$ )	$V_{S-} - 0.3\text{V}$ to $V_{S+} + 0.3\text{V}$
Differential Input Voltage (IN+ to IN-)	$\pm 4.8\text{V}$
Maximum Output Current	$\pm 60\text{mA}$
Input Current (all inputs and references)	4mA
<b>ESD Rating</b>	
Human Body Model	3kV
Machine Model	300V

**Thermal Information**

Storage Temperature Range	$-65^\circ\text{C}$ to $+150^\circ\text{C}$
Operating Junction Temperature	$+135^\circ\text{C}$
Ambient Operating Temperature	$-40^\circ\text{C}$ to $+85^\circ\text{C}$
Power Dissipation	See Curves
Pb-Free Reflow Profile	see <a href="#">TB493</a>

CAUTION: Do not operate at or near the maximum ratings listed for extended periods of time. Exposure to such conditions may adversely impact product reliability and result in failures not covered by warranty.

**Electrical Specifications**  $V_{S+} = +5\text{V}$ ,  $V_{S-} = -5\text{V}$ ,  $T_A = +25^\circ\text{C}$ ,  $V_{IN} = 0\text{V}$ ,  $R_{LD} = 1\text{k}\Omega$ ,  $C_{LD} = 2.7\text{pF}$ , [ $R_F = 604\Omega$ ,  $R_G = 402\Omega$  (EL5178)], [ $R_F = 402\Omega$ ,  $R_G = 274\Omega$  (EL5378)], unless otherwise specified.

PARAMETER	DESCRIPTION	TEST CONDITIONS	MIN (Note 4)	TYP	MAX (Note 4)	UNIT
<b>AC PERFORMANCE</b>						
BW	-3dB Bandwidth	$A_V = 2$ , $C_{LD} = 2.7\text{pF}$		700		MHz
		$A_V = 5$ , $C_{LD} = 2.7\text{pF}$		80		MHz
		$A_V = 2$ , $C_{LD} = 2.7\text{pF}$ , $R_{LD} = 200\Omega$		320		MHz
BW	$\pm 0.1\text{dB}$ Bandwidth	$A_V = 2$ , $C_{LD} = 2.7\text{pF}$		45		MHz
SR	Slew Rate, Differential (EL5178)	$V_{OUT} = 3V_{P-P}$ , 20% to 80%	650	850		V/ $\mu\text{s}$
	Slew Rate, Differential (EL5378)	$V_{OUT} = 3V_{P-P}$ , 20% to 80%	650	1000		V/ $\mu\text{s}$
$t_{STL}$	Settling Time to 0.1%	$V_{OUT} = 2V_{P-P}$		35		ns
$t_{OVR}$	Output Overdrive Recovery Time	$A_V = 2$		20		ns
GBWP	Gain Bandwidth Product			350		MHz
$V_{REFBW}$ (-3dB)	$V_{REF}$ -3dB Bandwidth (EL5378)	$C_{LD} = 2.7\text{pF}$		110		MHz
$V_{REFSR+}$	$V_{REF}$ Slew Rate - Rise (EL5378)	$V_{OUT} = 2V_{P-P}$ , 20% to 80%		134		V/ $\mu\text{s}$
$V_{REFSR-}$	$V_{REF}$ Slew Rate - Fall (EL5378)	$V_{OUT} = 2V_{P-P}$ , 20% to 80%		70		V/ $\mu\text{s}$
$V_N$	Input Voltage Noise	At 10kHz		18		nV/ $\sqrt{\text{Hz}}$
$I_N$	Input Current Noise	At 10kHz		1.5		pA/ $\sqrt{\text{Hz}}$
HD2	Second Harmonic Distortion	$V_{OUT} = 2V_{P-P}$ , 5MHz		-83		dBc
		$V_{OUT} = 2V_{P-P}$ , 20MHz		-72		dBc
HD3	Third Harmonic Distortion	$V_{OUT} = 2V_{P-P}$ , 5MHz		-88		dBc
		$V_{OUT} = 2V_{P-P}$ , 20MHz		-70		dBc
dG	Differential Gain at 3.58MHz	$R_{LD} = 300\Omega$ , $A_V = 2$		0.06		%
d $\theta$	Differential Phase at 3.58MHz	$R_{LD} = 300\Omega$ , $A_V = 2$		0.13		$^\circ$
$e_S$	Channel Separation (EL5378)	At $F = 1\text{MHz}$		90		dB
<b>INPUT CHARACTERISTICS</b>						
$V_{OS}$	Input Referred Offset Voltage			$\pm 1.9$	$\pm 30$	mV
$I_{IN}$	Input Bias Current ( $V_{IN+}$ , $V_{IN-}$ )		-20	-14	-7	$\mu\text{A}$
$I_{REF}$	Input Bias Current ( $V_{REF}$ ) (EL5378)	$V_{REF} = \pm 3.0\text{V}$	0.05	2.3	4	$\mu\text{A}$
$R_{IN}$	Differential Input Resistance			150		k $\Omega$
$C_{IN}$	Differential Input Capacitance			1		pF
DMIR	Differential Mode Input Range (EL5378)			$\pm 2.3$		V

**Electrical Specifications**  $V_{S+} = +5V$ ,  $V_{S-} = -5V$ ,  $T_A = +25^\circ C$ ,  $V_{IN} = 0V$ ,  $R_{LD} = 1k\Omega$ ,  $C_{LD} = 2.7pF$ , [ $R_F = 604\Omega$ ,  $R_G = 402\Omega$  (EL5178)], [ $R_F = 402\Omega$ ,  $R_G = 274\Omega$  (EL5378)], unless otherwise specified. **(Continued)**

PARAMETER	DESCRIPTION	TEST CONDITIONS	MIN (Note 4)	TYP	MAX (Note 4)	UNIT
CMIR+	Common-Mode Positive Input Range at $V_{IN+}$ , $V_{IN-}$ (EL5378)		3.1	3.4		V
CMIR-	Common-Mode Negative Input Range at $V_{IN+}$ , $V_{IN-}$ (EL5378)			-4.4	-4.1	V
$V_{REFIN+}$	Positive Reference Input Voltage Range (EL5378)	$V_{IN+} = V_{IN-} = 0V$	3.2	3.7		V
$V_{REFIN-}$	Negative Reference Input Voltage Range (EL5378)	$V_{IN+} = V_{IN-} = 0V$		-3.3	-3.2	V
$V_{REFOS}$	Output Offset Relative to $V_{REF}$ (EL5378)			$\pm 50$	$\pm 100$	mV
CMRR	Input Common-Mode Rejection Ratio	$V_{IN} = \pm 2.5V$	65	78		dB
<b>OUTPUT CHARACTERISTICS</b>						
$V_{OUT}$	Output Voltage Swing	$R_L = 1k\Omega$	$\pm 3.4$	$\pm 3.7$		V
$I_{OUT(Max)}$	Maximum Output Current	$R_L = 10\Omega$ , $V_{IN+} = \pm 3.2V$	$\pm 50$	$\pm 60$	$\pm 100$	mA
$R_{OUT}$	Output Impedance			130		m $\Omega$
<b>SUPPLY</b>						
$V_{SUPPLY}$	Supply Operating Range	$V_{S+}$ to $V_{S-}$	4.75		11	V
$I_{S(ON)}$	Power Supply Current - Per Channel		10	12.5	14	mA
$I_{S(OFF)+}$	Positive Power Supply Current - Disabled (EL5378)	$\overline{EN}$ pin tied to 4.8V		1.7	10	$\mu A$
$I_{S(OFF)-}$	Negative Power Supply Current - Disabled (EL5378)		-200	-120		$\mu A$
PSRR	Power Supply Rejection Ratio	$V_S$ from $\pm 4.5V$ to $\pm 5.5V$	60	75		dB
<b>ENABLE (EL5378 ONLY)</b>						
$t_{EN}$	Enable Time			130		ns
$t_{DS}$	Disable Time			1.2		$\mu s$
$V_{IH}$	$\overline{EN}$ Pin Voltage for Power-Up				$V_{S+} - 1.5$	V
$V_{IL}$	$\overline{EN}$ Pin Voltage for Shutdown		$V_{S+} - 0.5$			V
$I_{IH-EN}$	$\overline{EN}$ Pin Input Current High	At $V_{EN} = 5V$		123	200	$\mu A$
$I_{IL-EN}$	$\overline{EN}$ Pin Input Current Low	At $V_{EN} = 0V$	-20	-8		$\mu A$

**NOTE:**

4. Parameters with MIN and/or MAX limits are 100% tested at  $+25^\circ C$ , unless otherwise specified. Temperature limits established by characterization and are not production tested.

## Typical Performance Curves

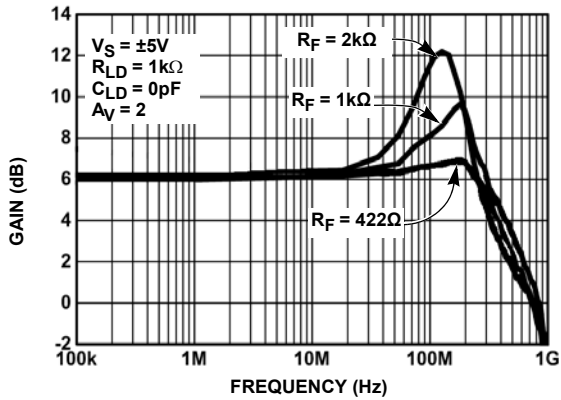

FIGURE 1. EL5178 FREQUENCY RESPONSE FOR VARIOUS  $R_f$

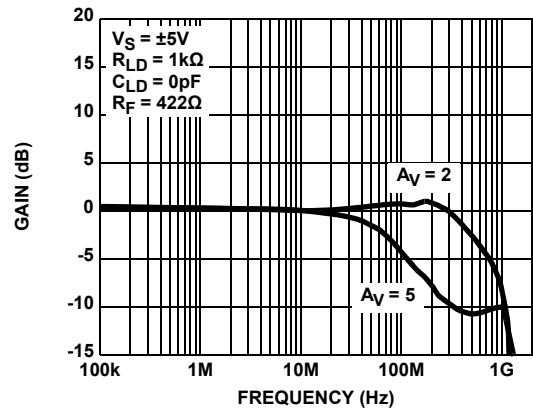

FIGURE 2. EL5178 FREQUENCY RESPONSE FOR VARIOUS GAIN

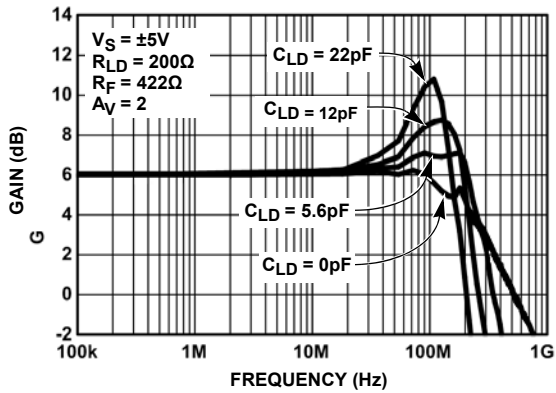

FIGURE 3. EL5178 FREQUENCY RESPONSE FOR VARIOUS  $C_{LD}$

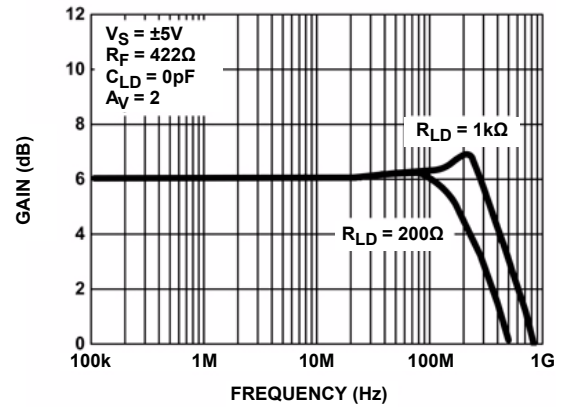

FIGURE 4. EL5178 FREQUENCY RESPONSE FOR VARIOUS  $R_{LD}$

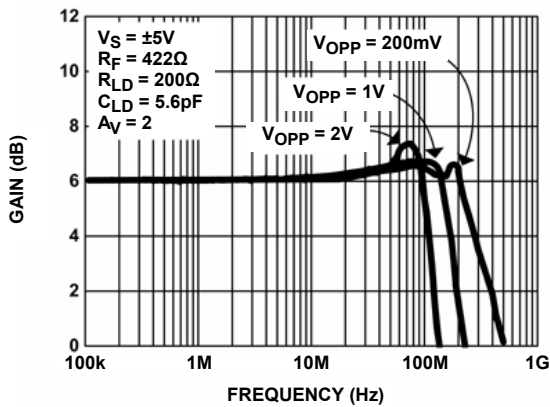

FIGURE 5. EL5178 FREQUENCY RESPONSE FOR VARIOUS  $V_{OPP}$

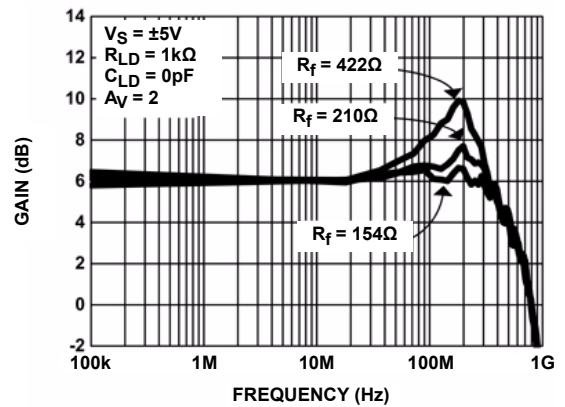

FIGURE 6. EL5378 FREQUENCY RESPONSE FOR VARIOUS  $R_f$

## Typical Performance Curves (Continued)

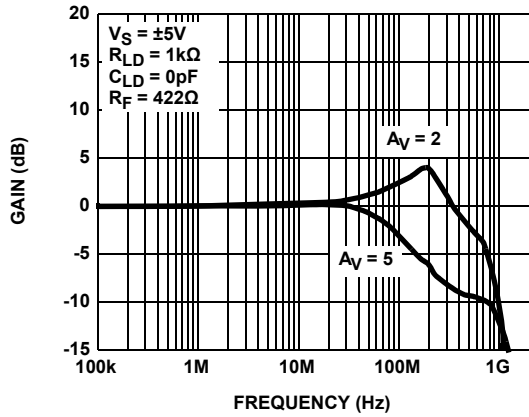

FIGURE 7. EL5378 FREQUENCY RESPONSE FOR VARIOUS GAIN

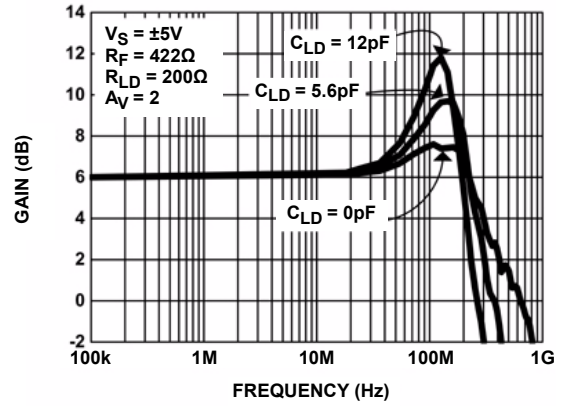

FIGURE 8. EL5378 FREQUENCY RESPONSE FOR VARIOUS  $C_{LD}$

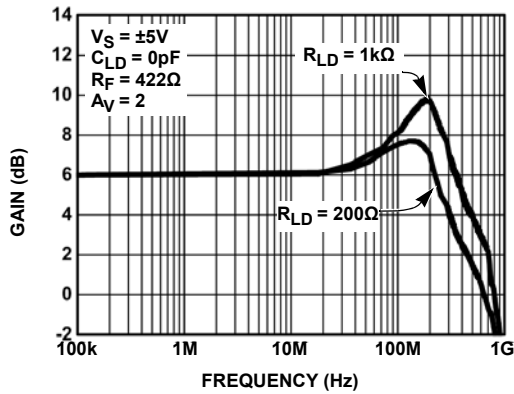

FIGURE 9. EL5378 FREQUENCY RESPONSE FOR VARIOUS  $R_{LD}$

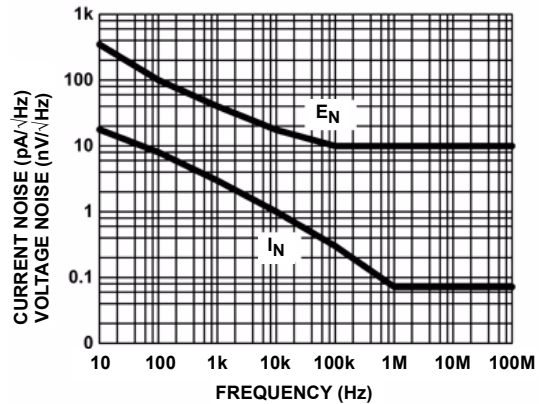

FIGURE 10. VOLTAGE AND CURRENT NOISE vs FREQUENCY

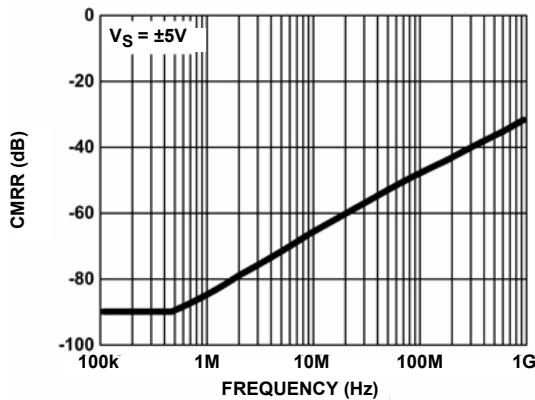

FIGURE 11. CMRR vs FREQUENCY

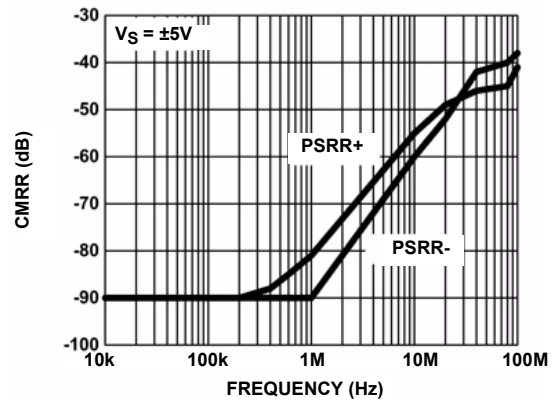

FIGURE 12. DIFFERENTIAL PSRR vs FREQUENCY

## Typical Performance Curves (Continued)

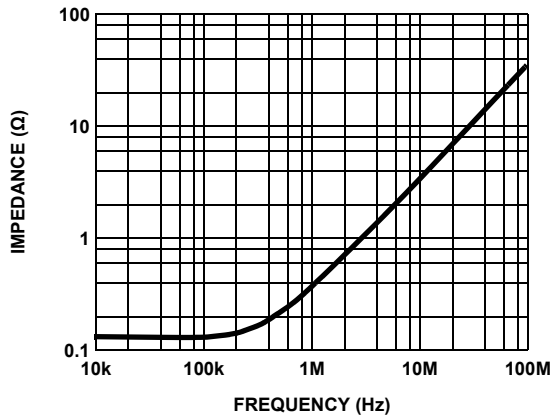

FIGURE 13. OUTPUT IMPEDANCE vs FREQUENCY

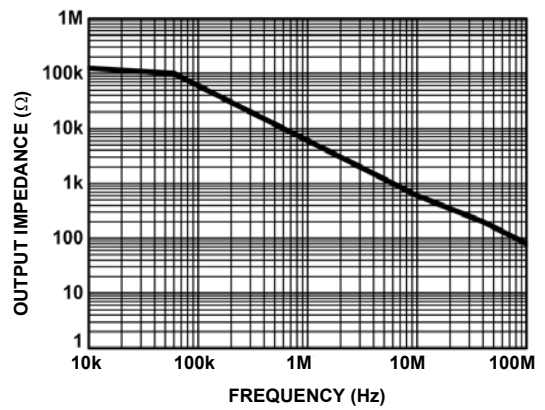

FIGURE 14. OUTPUT IMPEDANCE [DISABLED]

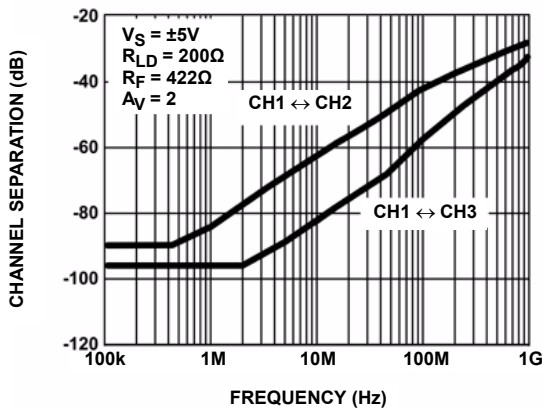

FIGURE 15. CHANNEL SEPARATION vs FREQUENCY

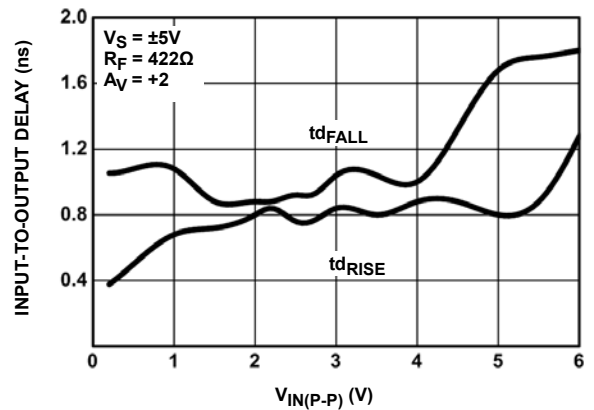

FIGURE 16. INPUT-TO-OUTPUT DELAY

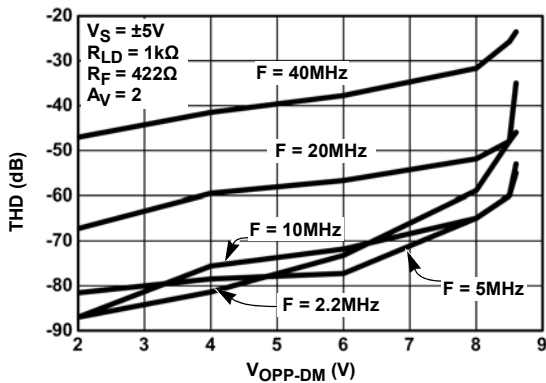

FIGURE 17. TOTAL HARMONIC DISTORTION vs DIFFERENTIAL OUTPUT SWING

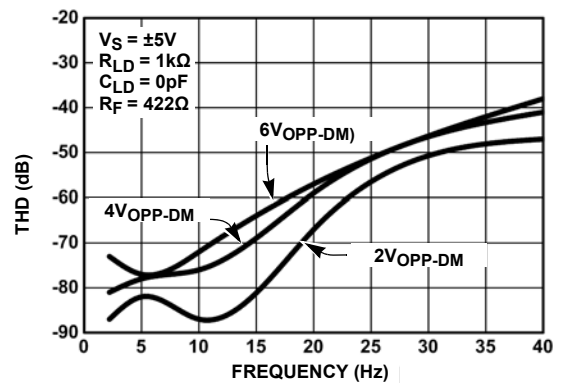

FIGURE 18. TOTAL HARMONIC DISTORTION vs FREQUENCY

# Typical Performance Curves (Continued)

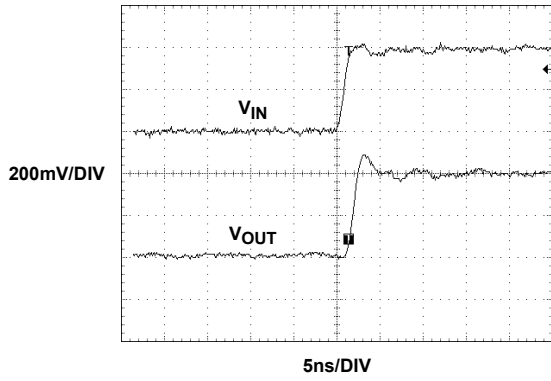

FIGURE 19. SMALL SIGNAL TRANSIENT RESPONSE

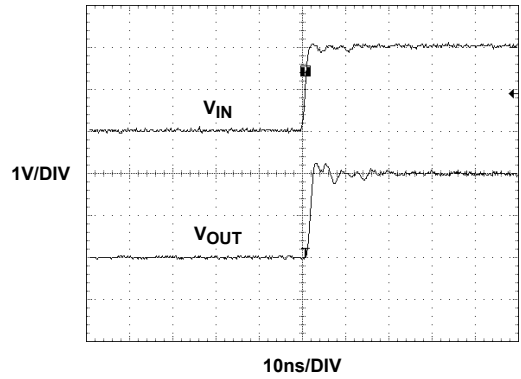

FIGURE 20. LARGE SIGNAL TRANSIENT RESPONSE

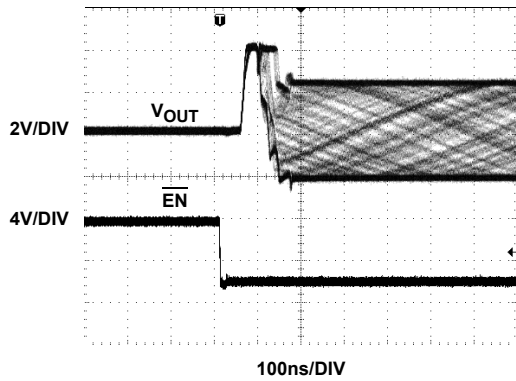

FIGURE 21. EL5378 ENABLED RESPONSE

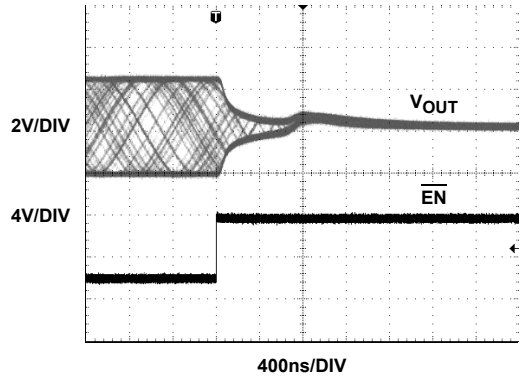

FIGURE 22. EL5378 DISABLED RESPONSE

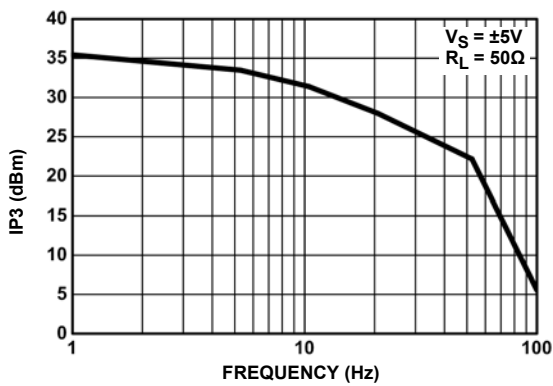

FIGURE 23. IP3 vs FREQUENCY

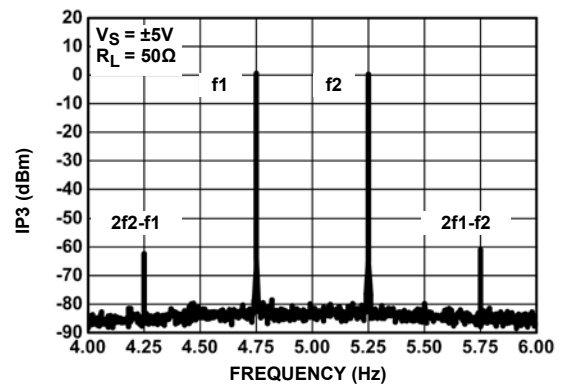

FIGURE 24. THIRD ORDER INTERCEPT POINT



## Typical Performance Curves (Continued)

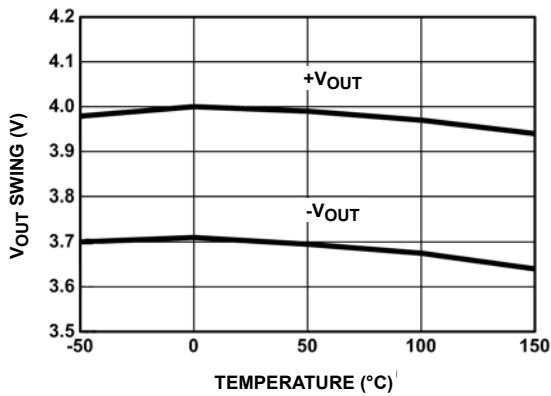

FIGURE 25. OUTPUT SWING vs TEMPERATURE

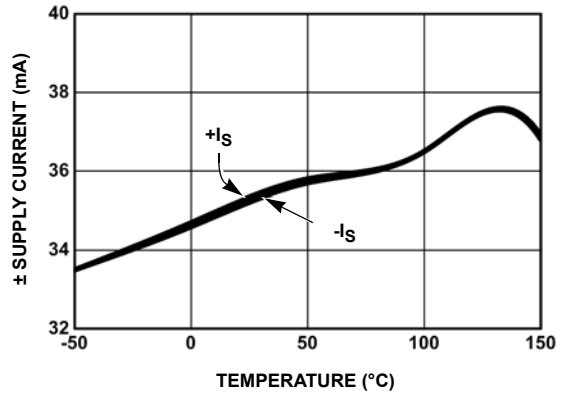

FIGURE 26. ± SUPPLY CURRENT vs TEMPERATURE

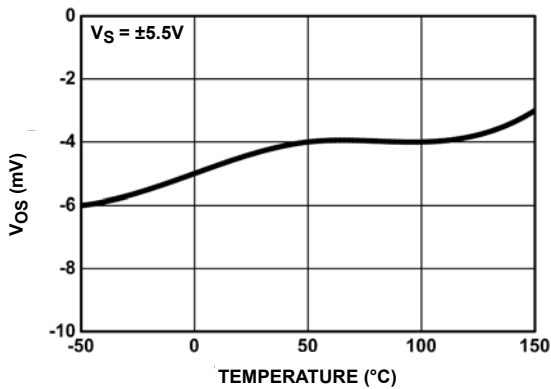

FIGURE 27. OFFSET VOLTAGE vs TEMPERATURE

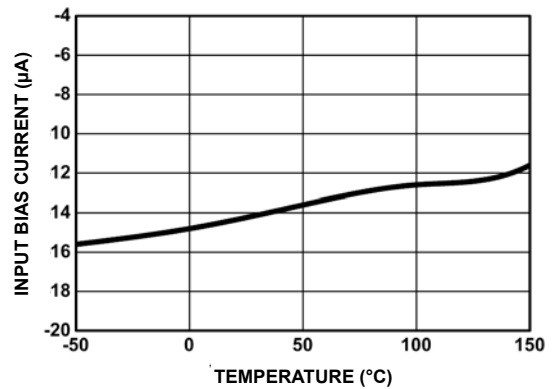

FIGURE 28. INPUT BIAS CURRENT vs TEMPERATURE

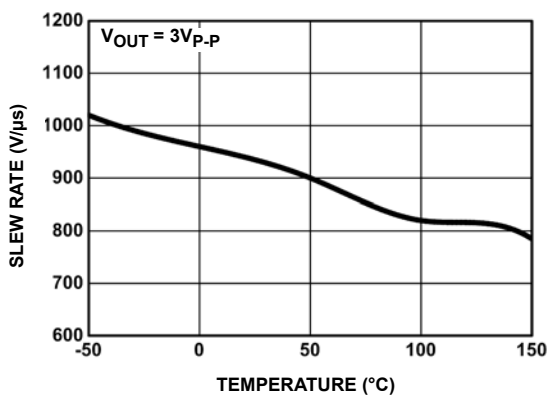

FIGURE 29. SLEW RATE vs TEMPERATURE

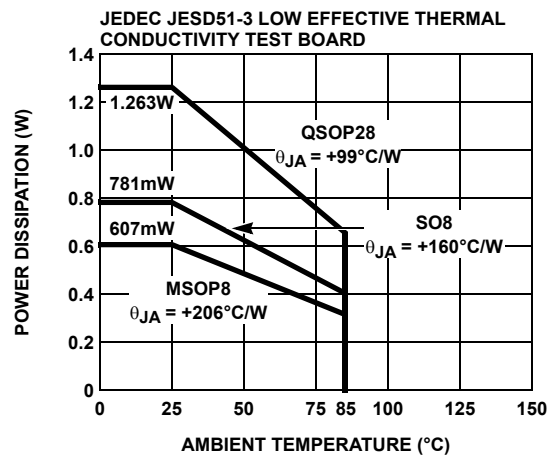

FIGURE 30. PACKAGE POWER DISSIPATION vs AMBIENT TEMPERATURE

## Typical Performance Curves (Continued)

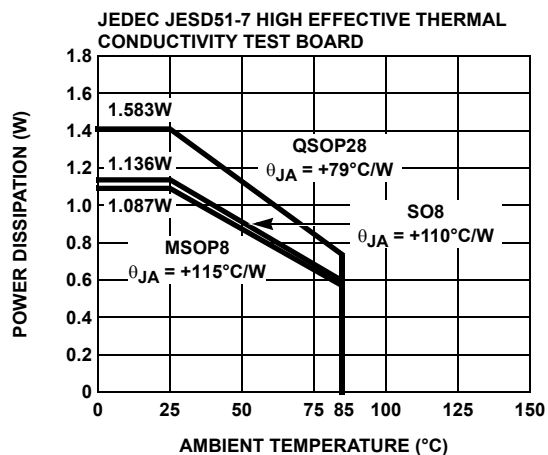

FIGURE 31. PACKAGE POWER DISSIPATION vs AMBIENT TEMPERATURE

# Connection Diagrams

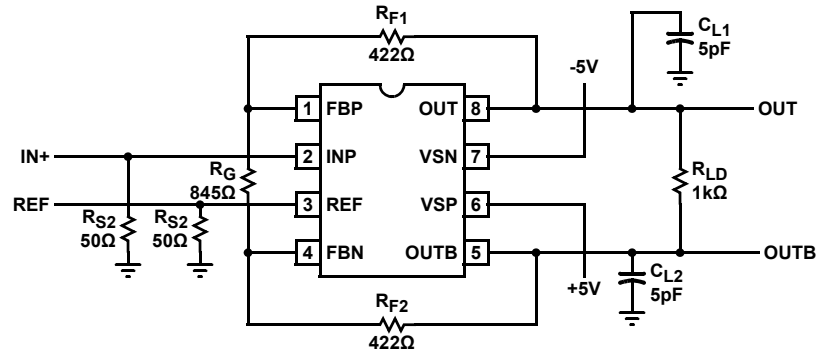

FIGURE 32. EL5178

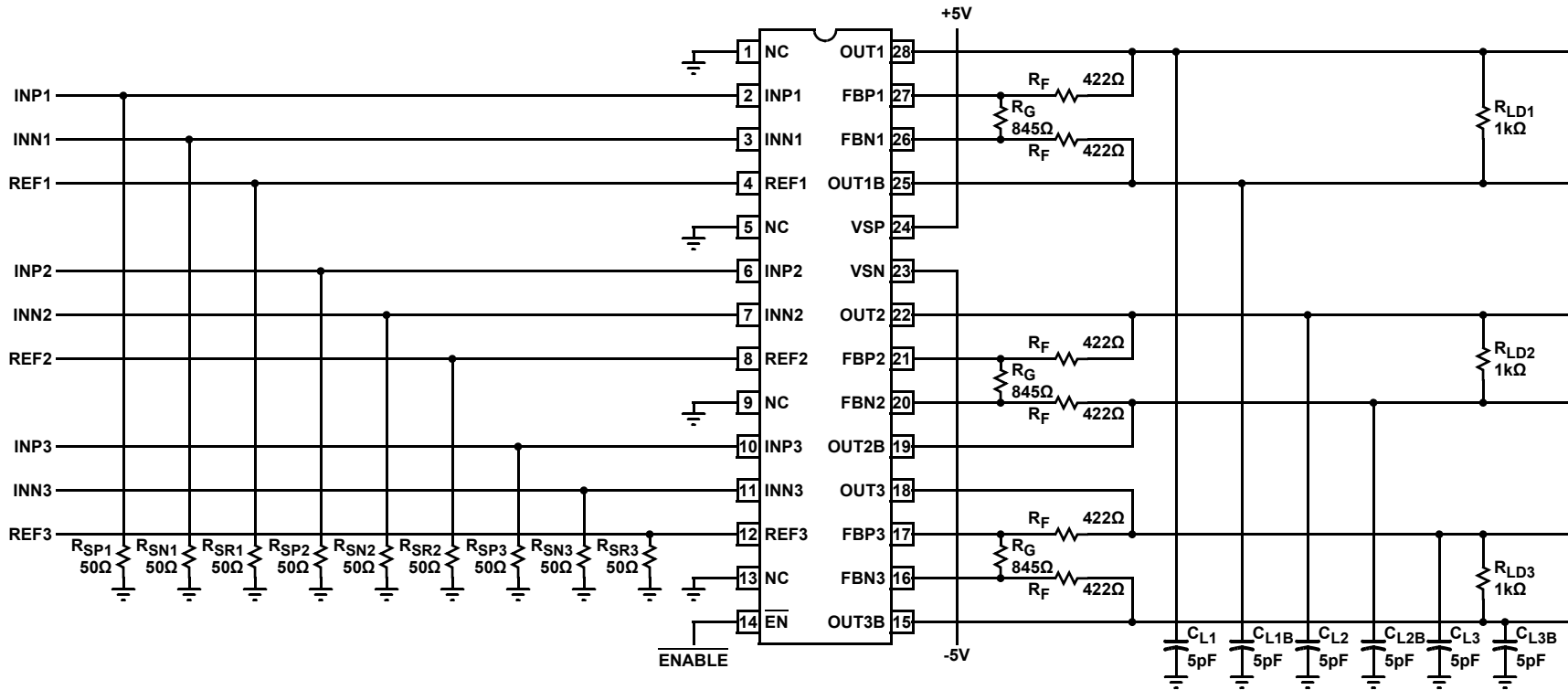

FIGURE 33. EL5378

## Simplified Schematic

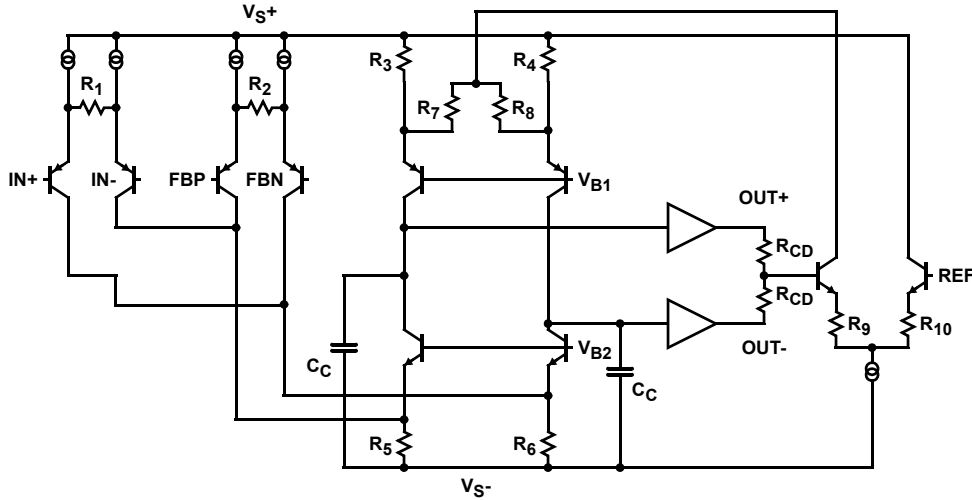

FIGURE 34. SIMPLIFIED SCHEMATIC

## Description of Operation and Application Information

### Product Description

The EL5178 and EL5378 are wide bandwidth, low power and single/differential ended to differential output amplifiers. The EL5178 is a single channel differential amplifier. Since the  $I_{N-}$  pin and REF pin are tied together internally, the EL5178 can be used as a single ended to differential converter. The EL5378 is a triple channel differential amplifier. The EL5378 has a separate  $I_{N-}$  pin and REF pin for each channel. It can be used as single/differential ended to differential converter. The EL5178 and EL5378 are internally compensated for closed loop gain of 2 or greater. Connected in gain of 2 and driving a 1k $\Omega$  differential load, the EL5178 and EL5378 have a -3dB bandwidth of 700MHz. Driving a 200 $\Omega$  differential load at gain of 2, the bandwidth is about 320MHz. The EL5378 is available with a power-down feature to reduce the power while the amplifier is disabled.

### Input, Output and Supply Voltage Range

The EL5178 and EL5378 have been designed to operate with a single supply voltage of 5V to 10V or split supplies with its total voltage from 5V to 10V. The amplifiers have an input common mode voltage range from -4.3V to 3.4V for  $\pm 5V$  supply. The differential mode input range (DMIR) between the two inputs is from -2.3V to +2.3V. The input voltage range at the REF pin is from -3.3V to 3.7V. If the input common mode or differential mode signal is outside the above-specified ranges, it will cause the output signal to become distorted.

The output of the EL5178 and EL5378 can swing from -3.8V to +3.8V at 1k $\Omega$  differential load at  $\pm 5V$  supply. As the load resistance becomes lower, the output swing is reduced.

### Differential and Common-Mode Gain Settings

For EL5178, since the  $I_{N-}$  pin and REF pin are bonded together as the REF pin in an 8 Ld package, the signal at the REF pin is part of

the common mode signal and also part of the differential mode signal. For the true balance differential outputs, the REF pin must be tied to the same bias level as the  $I_{N+}$  pin. For a  $\pm 5V$  supply, just tie the REF pin to GND if the  $I_{N+}$  pin is biased at 0V with a 50 $\Omega$  or 75 $\Omega$  termination resistor. For a single supply application, if the  $I_{N+}$  is biased to half of the rail, the REF pin should also be biased to half of the rail.

The gain setting for EL5178 is expressed in [Equation 1](#):

$$V_{ODM} = V_{IN+} \times \left( 1 + \frac{R_{F1} + R_{F2}}{R_G} \right)$$

$$V_{OCM} = V_{REF} = 0V$$

$$V_{ODM} = V_{IN+} \times \left( 1 + \frac{2R_F}{R_G} \right) \tag{EQ. 1}$$

Where:

$$V_{REF} = 0V$$

$$R_{F1} = R_{F2} = R_F$$

EL5378 has a separate  $I_{N-}$  pin and REF pin. It can be used as a single/differential ended to differential converter. The voltage applied at REF pin can set the output common mode voltage and the gain is one.

The gain setting for EL5378 is expressed in [Equation 2](#):

$$V_{ODM} = (V_{IN+} - V_{IN-}) \times \left( 1 + \frac{R_{F1} + R_{F2}}{R_G} \right)$$

$$V_{ODM} = (V_{IN+} - V_{IN-}) \times \left( 1 + \frac{2R_F}{R_G} \right) \tag{EQ. 2}$$

$$V_{OCM} = V_{REF}$$

Where:

$$R_{F1} = R_{F2} = R_F$$

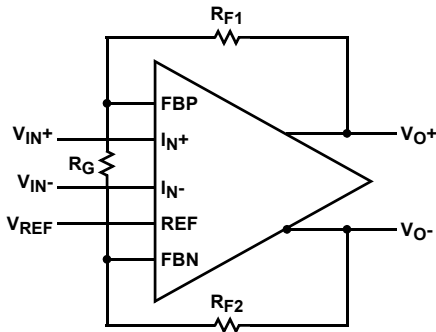

FIGURE 35.

### Choice of Feedback Resistor and Gain Bandwidth Product

The feedback resistor forms a pole with the parasitic capacitance at the inverting input. As this pole becomes smaller, the amplifier's phase margin is reduced. This causes ringing in the time domain and peaking in the frequency domain. Therefore,  $R_F$  has some maximum value that should not be exceeded for optimum performance. If a large value of  $R_F$  must be used, a small capacitor in the few Pico farad range in parallel with  $R_F$  can help to reduce the ringing and peaking at the expense of reducing the bandwidth.

The bandwidth of the EL5178 and EL5378 depends on the load and the feedback network.  $R_F$  and  $R_G$  appear in parallel with the load. As this combination gets smaller, the bandwidth falls off. Consequently,  $R_F$  also has a minimum value that should not be exceeded for optimum bandwidth performance. For the gains other than 1, optimum response is obtained with  $R_F$  between 500Ω to 1kΩ.

The EL5178 and EL5378 have a gain bandwidth product of 350MHz for  $R_{LD} = 1k\Omega$ . For gains  $\geq 5$ , its bandwidth can be predicted by [Equation 3](#):

$$\text{Gain} \times \text{BW} = 300\text{MHz} \tag{EQ. 3}$$

### Driving Capacitive Loads and Cables

The EL5178 and EL5378 can drive a 23pF differential capacitor in parallel with 200Ω differential load with less than 5dB of peaking at gain of 2. If less peaking is desired in applications, a small series resistor (usually between 5Ω to 50Ω) can be placed in series with each output to eliminate most peaking. However, this will reduce the gain slightly. If the gain setting is greater than 2, the gain resistor  $R_G$  can then be chosen to make up for any gain loss, which may be created by the additional series resistor at the output.

When used as a cable driver, double termination is always recommended for reflection-free performance. For those applications, a back-termination series resistor at the amplifier's output will isolate the amplifier from the cable and allow extensive capacitive drive. However, other applications may have high capacitive loads without a back-termination resistor. Again, a small series resistor at the output can help to reduce peaking.

### Disable/Power-Down (for EL5378 only)

The EL5378 can be disabled and its outputs placed in a high impedance state. The turn-off time is about 1.2μs and the turn-on time is about 130ns. When disabled, the amplifier's supply current is reduced to 1.7μA for  $I_{S+}$  and 120μA for  $I_{S-}$  typically, thereby effectively eliminating the power consumption. The amplifier's power-down can be controlled by standard CMOS signal levels at the EN pin. The applied logic signal is relative to the  $V_{S+}$  pin. Letting the  $\overline{\text{EN}}$  pin float or applying a signal that is less than 1.5V below  $V_{S+}$  will enable the amplifier. The amplifier will be disabled when the signal at the  $\overline{\text{EN}}$  pin is above  $V_{S+} - 0.5V$ .

### Output Drive Capability

The EL5178 and EL5378 have internal short-circuit protection. Its typical short-circuit current is  $\pm 60\text{mA}$ . If the output is shorted indefinitely, the power dissipation could easily increase such that the part will be destroyed. Maximum reliability is maintained if the output current never exceeds  $\pm 60\text{mA}$ . This limit is set by the design of the internal metal interconnections.

### Power Dissipation

With the high output drive capability of the EL5178 and EL5378, it is possible to exceed the +135°C absolute maximum junction temperature under certain load current conditions. Therefore, it is important to calculate the maximum junction temperature for the application to determine if the load conditions or package types need to be modified for the amplifier to remain in the safe operating area.

The maximum power dissipation allowed in a package is determined according to [Equation 4](#):

$$P_{D_{MAX}} = \frac{T_{J_{MAX}} - T_{A_{MAX}}}{\theta_{JA}} \tag{EQ. 4}$$

Where:

$T_{J_{MAX}}$  = Maximum junction temperature

$T_{A_{MAX}}$  = Maximum ambient temperature

$\theta_{JA}$  = Thermal resistance of the package

The maximum power dissipation actually produced by an IC is the total quiescent supply current times the total power supply voltage, plus the power in the IC due to the load, or as expressed in [Equation 5](#):

$$PD = i \times \left( V_{STOT} \times I_{S_{MAX}} + (V_{STOT} - \Delta V_O) \times \frac{\Delta V_O}{R_{LD}} \right) \tag{EQ. 5}$$

Where:

$V_{STOT}$  = Total supply voltage =  $V_{S+} - V_{S-}$

$I_{S_{MAX}}$  = Maximum quiescent supply current per channel

$\Delta V_O$  = Maximum differential output voltage of the application

$R_{LD}$  = Differential load resistance

$I_{LOAD}$  = Load current

$i$  = Number of channels by setting the two  $P_{D_{MAX}}$  equations equal to each other, we can solve the output current and  $R_{LD}$  to avoid the device overheat.

## Power Supply Bypassing and Printed Circuit Board Layout

As with any high frequency device, a good printed circuit board layout is necessary for optimum performance. Lead lengths should be as short as possible. The power supply pin must be well bypassed to reduce the risk of oscillation. For normal single supply operation, where the VS- pin is connected to the ground plane, a single 4.7µF tantalum capacitor in parallel with a 0.1µF ceramic capacitor from VS+ to GND will suffice. This same capacitor combination should be placed at each supply pin to ground if split supplies are to be used. In this case, the VS- pin becomes the negative supply rail.

For good AC performance, parasitic capacitance should be kept to a minimum. Use of wire-wound resistors should be avoided because of their additional series inductance. Use of sockets should also be avoided if possible. Sockets add parasitic inductance and capacitance that can result in compromised performance. Minimizing parasitic capacitance at the amplifier's inverting input pin is very important. The feedback resistor should be placed very close to the inverting input pin. Strip line design techniques are recommended for the signal traces.

As the signal is transmitted through a cable, the high frequency signal will be attenuated. One way to compensate this loss is to boost the high frequency gain at the receiver side.

## Typical Applications

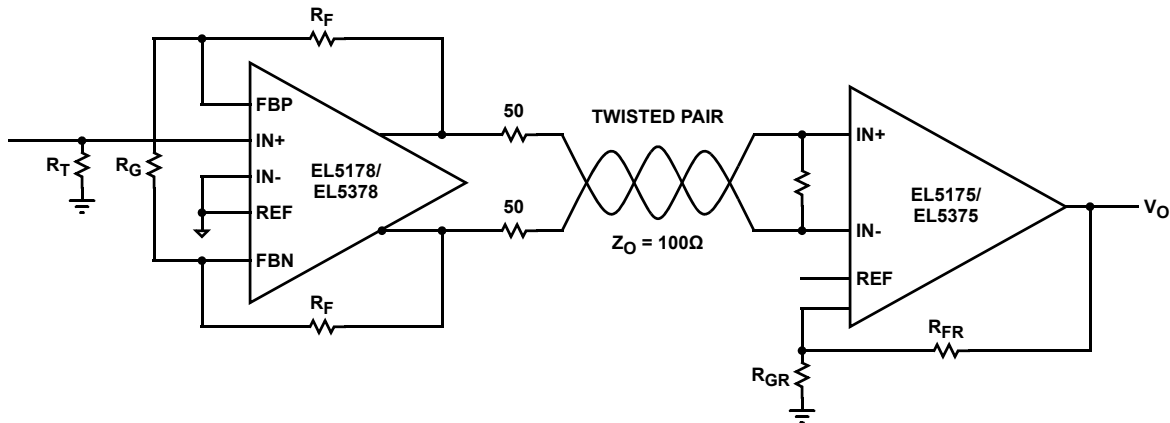
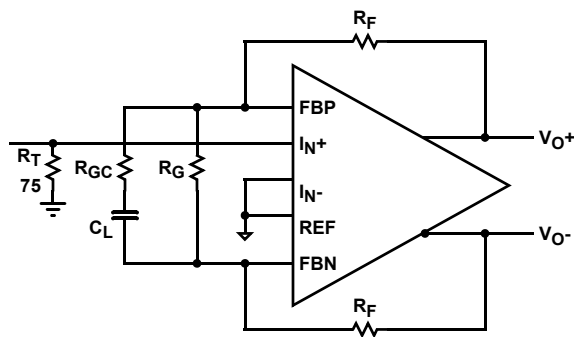
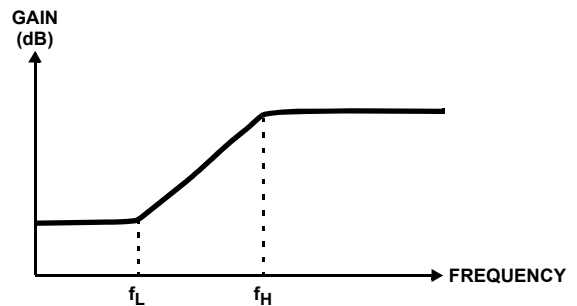

FIGURE 36. TWISTED PAIR CABLE RECEIVER



$$\text{DC Gain} = 1 + \frac{2R_F}{R_G}$$

$$\text{(HF)Gain} = 1 + \frac{2R_F}{R_G \parallel R_{GC}}$$



$$f_L \cong \frac{1}{2\pi R_G C_C}$$

$$f_H \cong \frac{1}{2\pi R_{GC} C_C}$$

FIGURE 37. TRANSMIT EQUALIZER

## Revision History

The revision history provided is for informational purposes only and is believed to be accurate, but not warranted. Please go to the web to make sure that you have the latest revision.

DATE	REVISION	CHANGE
February 4, 2016	FN7491.7	<p>Added "No longer available" across the 5178 pinout on page 1.</p> <p>Updated "Ordering Information" on page 2 by adding Temp Range column and updating tape and reel note to show options.</p> <p>Added "No longer available" under the "EL5178" header of "Pin Descriptions" on page 2.</p> <p>Changed "gain of 1" to "gain of 2" 1st paragraph under "Product Description" on page 12.</p> <p>Changed "bounded" to "bonded".in 1st sentence under "Differential and Common-Mode Gain Settings" on page 12.</p> <p>Deleted from 1st and 2nd paragraph in "Choice of Feedback Resistor and Gain Bandwidth Product" on page 13 "For gains greater than 1," and "for gains other than 1"</p>
August 19, 2015	FN7491.6	<p>Updated Ordering Information table on page 2.</p> <p>Added Revision History and About Intersil sections.</p>

## About Intersil

Intersil Corporation is a leading provider of innovative power management and precision analog solutions. The company's products address some of the largest markets within the industrial and infrastructure, mobile computing and high-end consumer markets.

For the most updated datasheet, application notes, related documentation and related parts, please see the respective product information page found at [www.intersil.com](http://www.intersil.com).

You may report errors or suggestions for improving this datasheet by visiting [www.intersil.com/ask](http://www.intersil.com/ask).

Reliability reports are also available from our website at [www.intersil.com/support](http://www.intersil.com/support)

# Package Outline Drawing

## M8.15E

### 8 LEAD NARROW BODY SMALL OUTLINE PLASTIC PACKAGE

Rev 0, 08/09

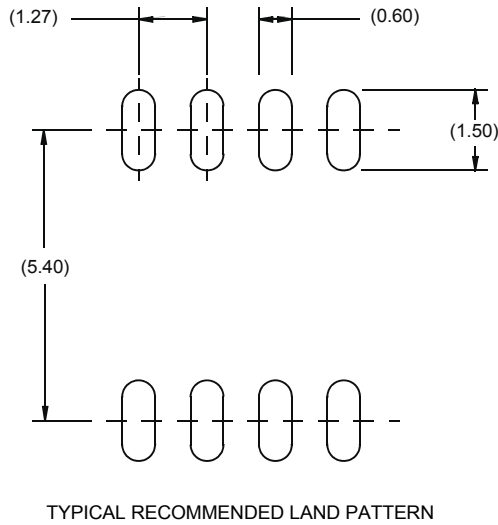
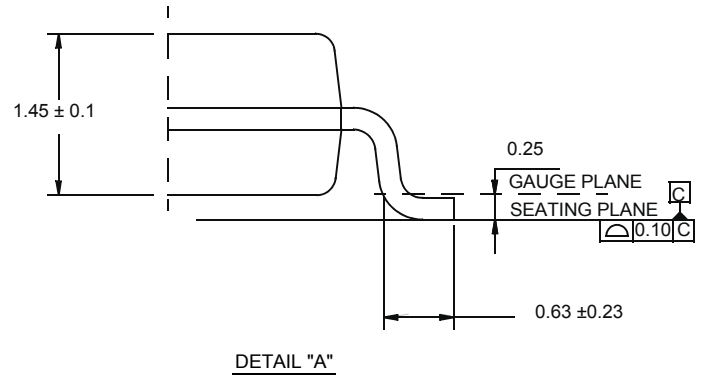
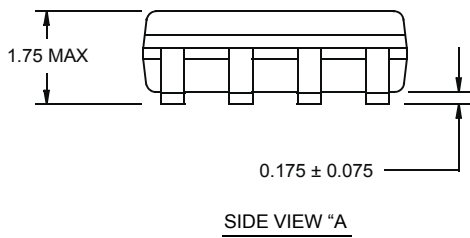
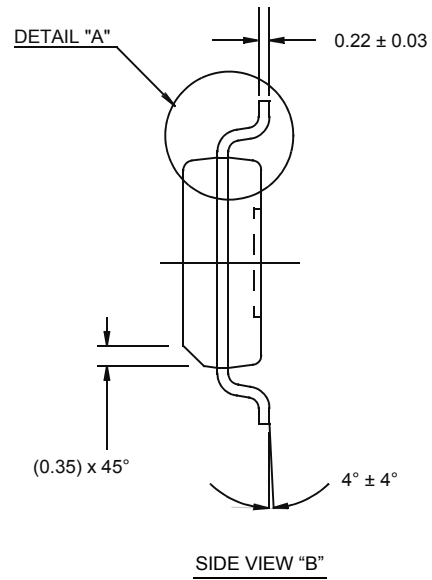
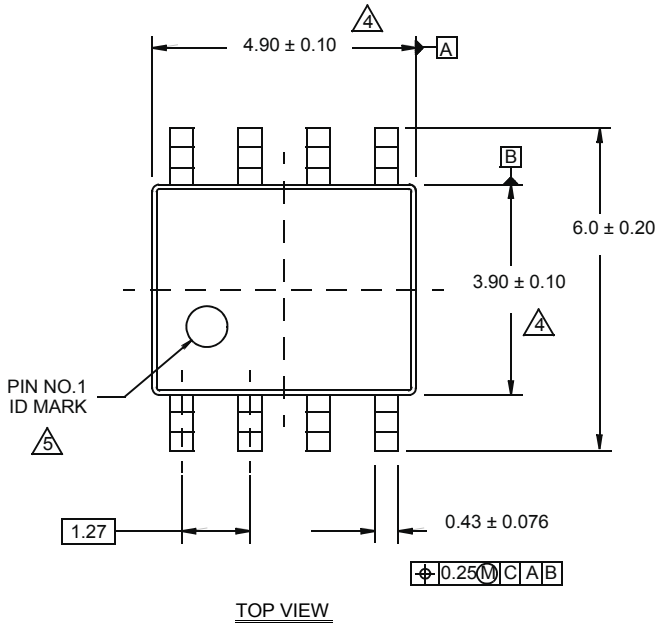

**NOTES:**

1. Dimensions are in millimeters.  
Dimensions in ( ) for Reference Only.
2. Dimensioning and tolerancing conform to AMSE Y14.5m-1994.
3. Unless otherwise specified, tolerance : Decimal ± 0.05
4. Dimension does not include interlead flash or protrusions.  
Interlead flash or protrusions shall not exceed 0.25mm per side.
5. The pin #1 identifier may be either a mold or mark feature.
6. Reference to JEDEC MS-012.



# Package Outline Drawing

## M8.118A

8 LEAD MINI SMALL OUTLINE PLASTIC PACKAGE (MSOP)

Rev 0, 9/09

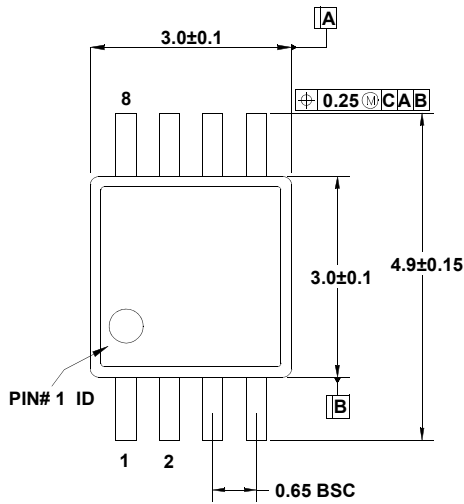

TOP VIEW

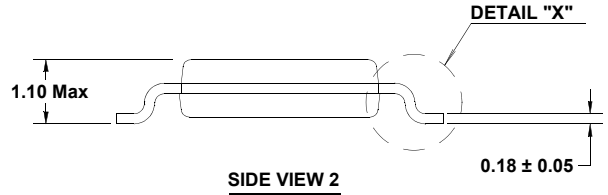

SIDE VIEW 2

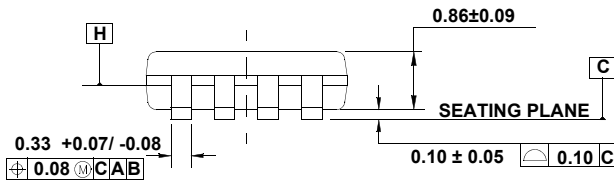

SIDE VIEW 1

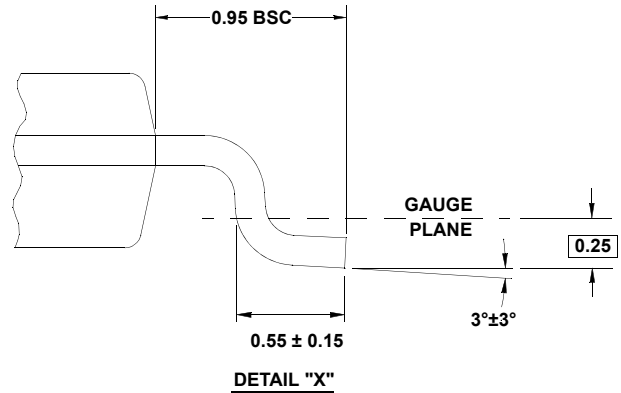

DETAIL "X"

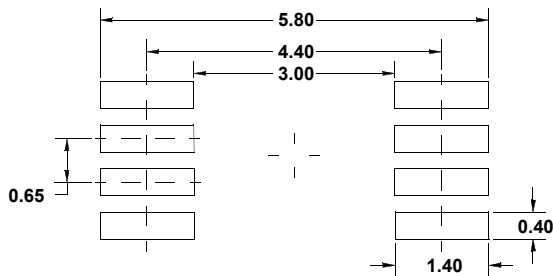

TYPICAL RECOMMENDED LAND PATTERN

NOTES:

1. Dimensions are in millimeters.
2. Dimensioning and tolerancing conform to JEDEC MO-187-AA and AMSE Y14.5m-1994.
3. Plastic or metal protrusions of 0.15mm max per side are not included.
4. Plastic interlead protrusions of 0.25mm max per side are not included.
5. Dimensions "D" and "E1" are measured at Datum Plane "H".
6. This replaces existing drawing # MDP0043 MSOP 8L.