

## Features

- 3.3 and 5 VDC voltage supply option
- Absolute
- Bushing or servo mount
- Non-contacting magnetic technology
- Small size
- CMOS and TTL compatible
- Resolution: 1024 positions
- Long life
- High operating speed
- Highly repeatable
- Sealed option
- Magnetic technology

## EMS22A - Non-Contacting Absolute Encoder

### Electrical Characteristics

Resolution .....	1024 positions
Insulation Resistance (500 VDC) .....	1,000 megohms
Electrical Travel .....	Continuous
Supply Voltage .....	5.0 VDC $\pm 10\%$ , 3.3 VDC $\pm 10\%$
Supply Current .....	20 mA maximum
Output Voltage	
Low Output Level .....	Vss+0.4 V maximum
High Output Level .....	Vdd-0.5 V minimum
Output Current	
With 4.5 VDC Supply Voltage .....	4 mA maximum
With 3.0 VDC Supply Voltage .....	2 mA maximum
Rise/Fall Time (Incremental Output) .....	500 ns maximum
Shaft RPM (Ball Bearing) .....	10,000 rpm maximum
Linearity .....	0.5 %
Accuracy	
Nominal .....	$\pm 0.7^\circ$ or better
Worst Case .....	$\pm 1.4^\circ$
Output Transition Noise .....	0.12 $^\circ$ RMS max.

### Environmental Characteristics

Operating Temperature Range .....	-40 $^\circ$ C to +125 $^\circ$ C (-40 $^\circ$ F to +257 $^\circ$ F)
Storage Temperature Range .....	-55 $^\circ$ C to +125 $^\circ$ C (-67 $^\circ$ F to +257 $^\circ$ F)
Humidity .....	MIL-STD-202, Method 103B, Condition B
Vibration .....	15 G
Shock .....	50 G
Rotational Life	
S Bushing (@1,000 rpm) .....	100,000,000 revolutions
T & W Bushings (@1,000 rpm with 250 g side load) .....	50,000,000 revolutions
IP Rating .....	IP 65

### Mechanical Characteristics

Mechanical Angle .....	360 $^\circ$ Continuous
Torque	
Starting .....	43 $\pm 21$ g-cm (0.6 $\pm 0.3$ oz-in.)
Running .....	29 $\pm 14$ g-cm (0.4 $\pm 0.2$ oz-in.)
Mounting Torque .....	203 N-cm (18 lb.-in.)
Shaft End Play .....	0.30 mm (0.012 ") T.I.R. maximum
Shaft Radial Play .....	0.12 mm (0.005 ") T.I.R. maximum
Weight .....	11 gms. (0.4 oz.)
Terminals .....	Axial, radial or ribbon cable
Soldering Condition	
Manual Soldering .....	96.5Sn/3.0Ag/0.5Cu solid wire or no-clean rosin cored wire 370 $^\circ$ C (700 $^\circ$ F) max. for 3 seconds
Wave Soldering .....	96.5Sn/3.0Ag/0.5Cu solder with no-clean flux 260 $^\circ$ C (500 $^\circ$ F) max. for 10 seconds
Wash processes .....	Not recommended
Marking .....	Manufacturer's trademark, name, part number, and date code.
Hardware .....	One lockwasher and one mounting nut supplied with each encoder, except on servo mount versions.

### Pin Configuration

Output Type	Pin 1 (DI) <sup>(1)</sup>	Pin 2 (CLK)	Pin 3	Pin 4 (DO)	Pin 5	Pin 6
Absolute	Digital Input	Clock	GND	Digital Output	VCC <sup>(2)</sup>	CS

(1) Pin 1 (DI) should be grounded when in a single sensor configuration.

(2) Can be 5 or 3.3 VDC depending on the version.



**WARNING Cancer and Reproductive Harm - [www.P65Warnings.ca.gov](http://www.P65Warnings.ca.gov)**

\*RoHS Directive 2015/863, Mar 31, 2015 and Annex.

Specifications are subject to change without notice.

Users should verify actual device performance in their specific applications.

The products described herein and this document are subject to specific legal disclaimers as set forth on the last page of this document, and at [www.bourns.com/docs/legal/disclaimer.pdf](http://www.bourns.com/docs/legal/disclaimer.pdf).

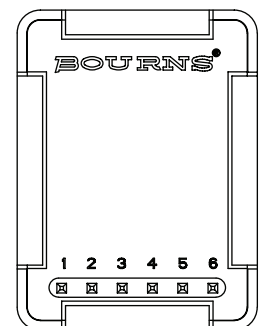

## Applications

- Material handling equipment
- Brushless DC motor commutation
- Robotics
- Automotive
- Industrial automation
- Petroleum refinery
- Medical (low/medium risk)\*
- Office equipment
- Audio and broadcast equipment

# EMS22A - Non-Contacting Absolute Encoder

**BOURNS®**

## Output Type Waveform and Variant Table

### Absolute Output

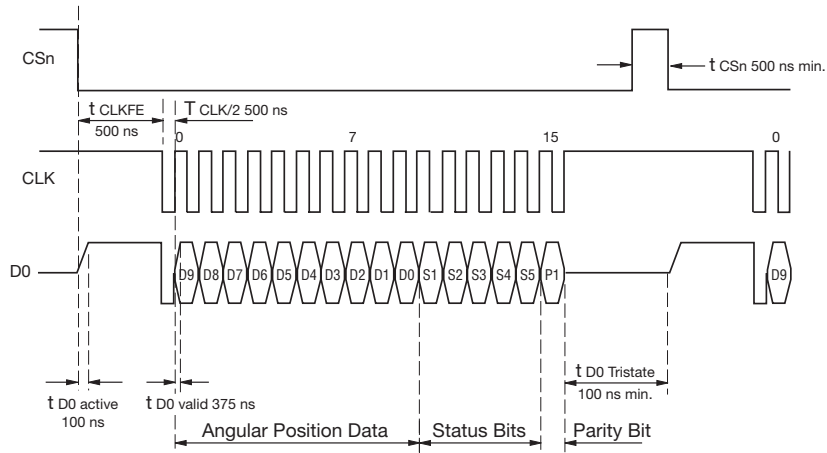

Data Content	Description
D9:D0	Absolute angular position data
S1	End of offset compensation algorithm
S2	Cordic overflow indicating an error in cordic part
S3	Linearity alarm
S4	Increase in magnetic magnitude
S5	Decrease in magnetic magnitude
P1	Even parity for detecting bits 1-15 transmission error

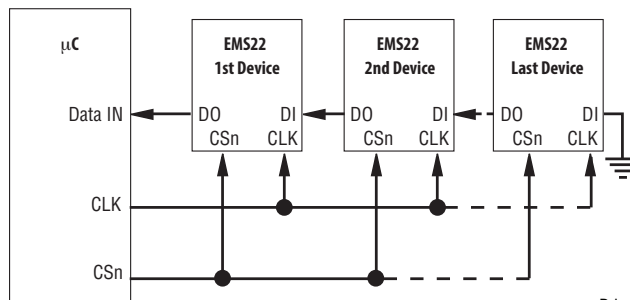

Daisy Chain Hardware Configuration

D is an extra clock cycle between sensor readings when in a daisy chain configuration.

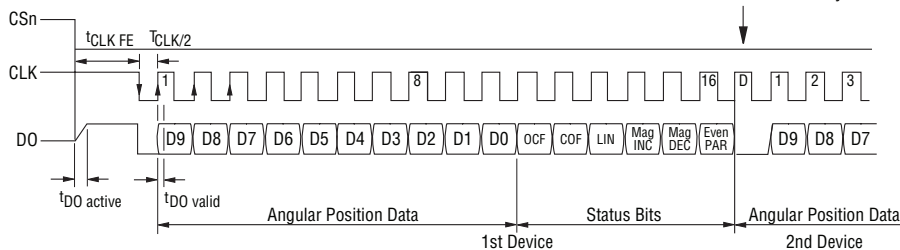

Daisy Chain Mode Data Transfer

\* Bourns® products have not been designed for and are not intended for use in "lifesaving," "life-critical" or "life-sustaining" applications nor any other applications where failure or malfunction of the Bourns® product may result in personal injury or death. See Legal Disclaimer Notice [www.bourns.com/docs/legal/disclaimer.pdf](http://www.bourns.com/docs/legal/disclaimer.pdf). Specifications are subject to change without notice.

Users should verify actual device performance in their specific applications. The products described herein and this document are subject to specific legal disclaimers as set forth on the last page of this document, and at [www.bourns.com/docs/legal/disclaimer.pdf](http://www.bourns.com/docs/legal/disclaimer.pdf).

Consult factory for options not shown, including:

- Wire lead or cable options
- Connectors
- Non-standard resolutions
- Special shaft/bushing sizes and features
- Special performance characteristics
- PCB mounting bracket

## EMS22A - Non-Contacting Absolute Encoder

**BOURNS®**

### Product Dimensions

#### Shaft Style D (Bushing T)

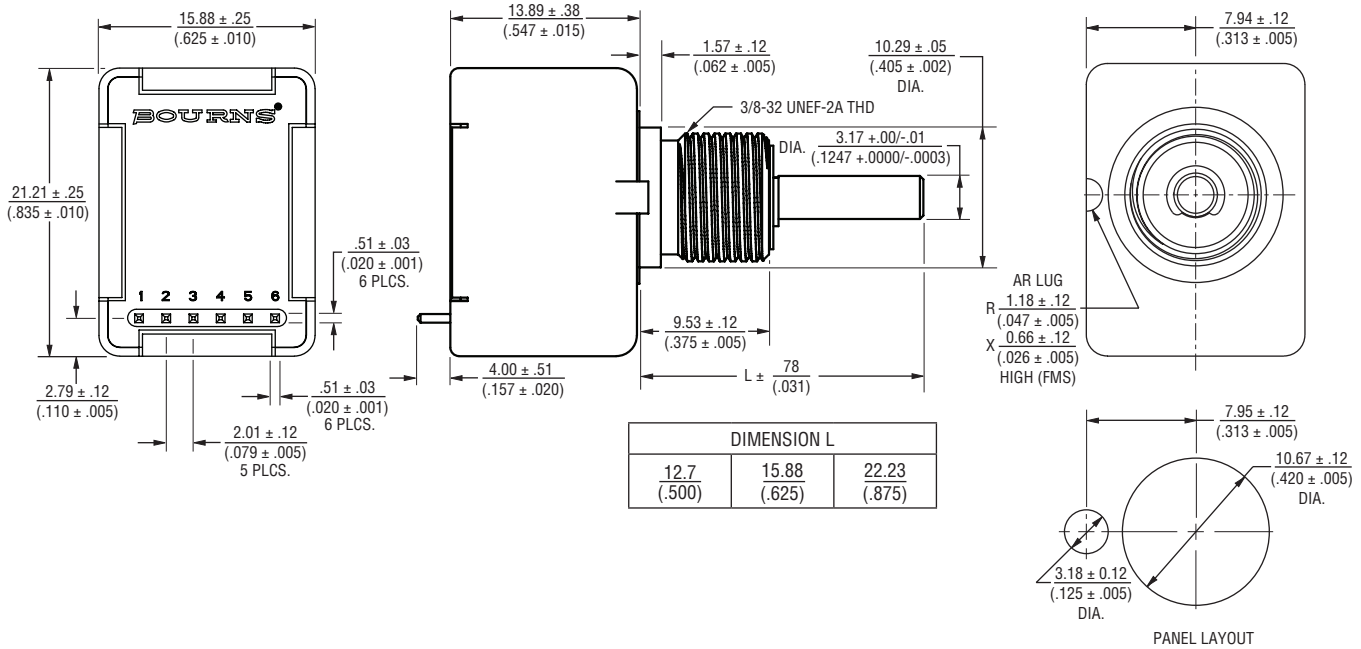

#### Shaft Style B (Bushing S)

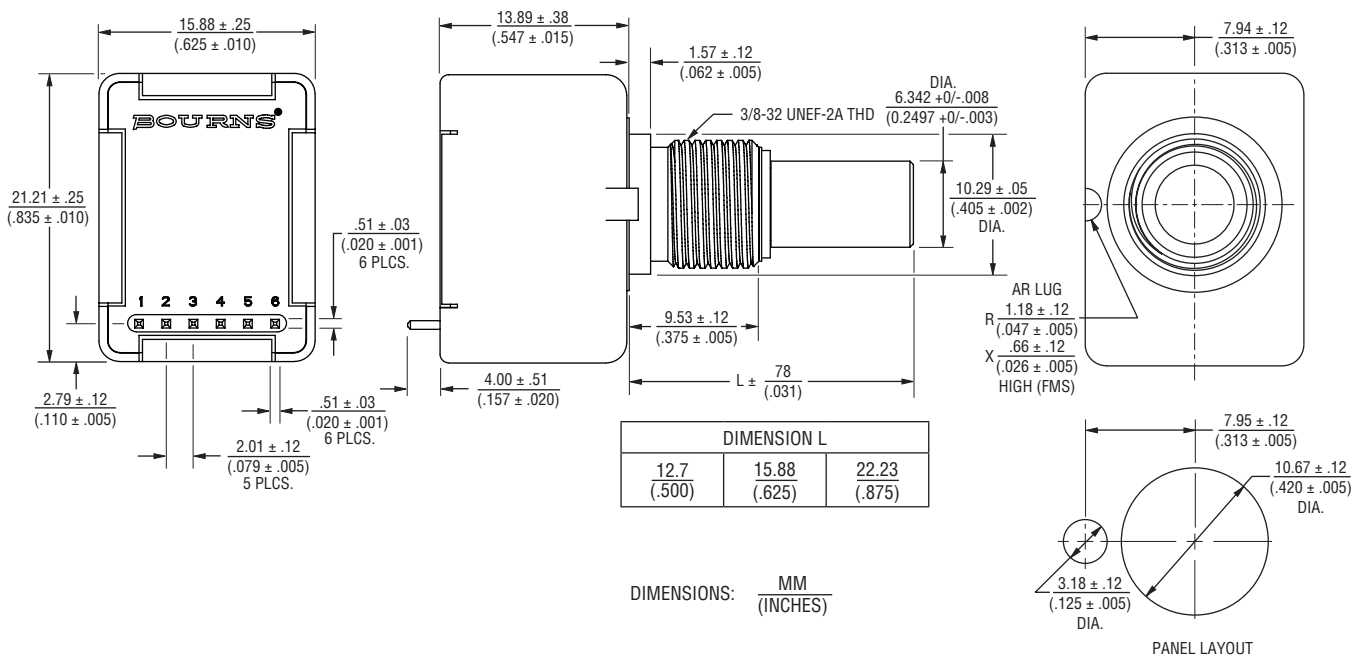

Specifications are subject to change without notice.

Users should verify actual device performance in their specific applications.

The products described herein and this document are subject to specific legal disclaimers as set forth on the last page of this document, and at [www.bourns.com/docs/legal/disclaimer.pdf](http://www.bourns.com/docs/legal/disclaimer.pdf).

# EMS22A - Non-Contacting Absolute Encoder

**BOURNS®**

## Product Dimensions

### Shaft Style D (Bushing W)

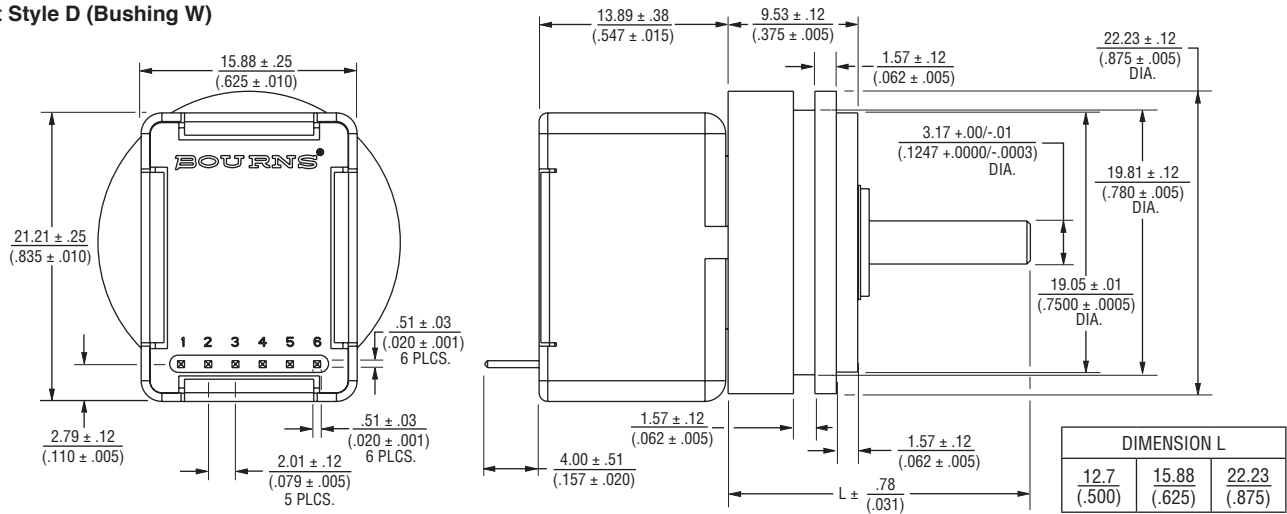

### Shaft Style C (Bushing S)

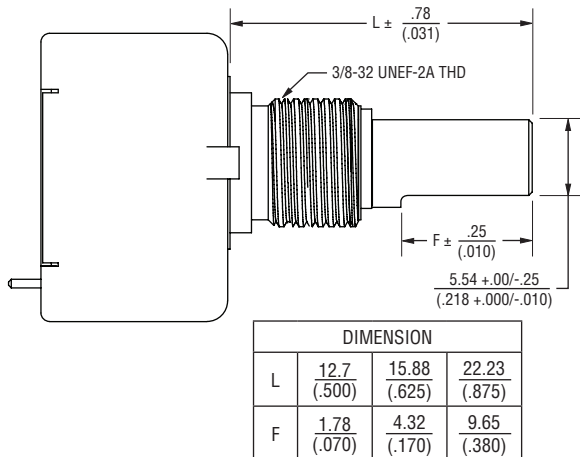

### Shaft Style M (Bushing D)

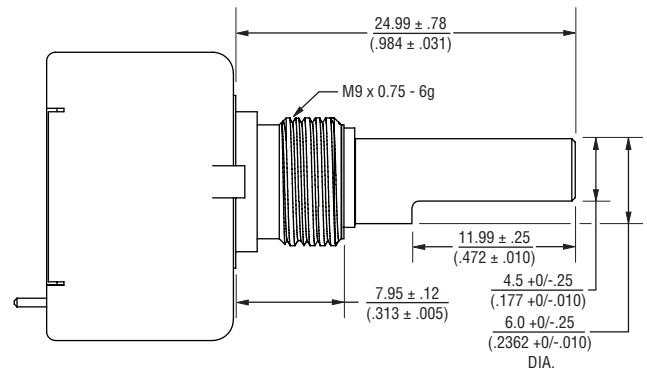

### Cable Assembly

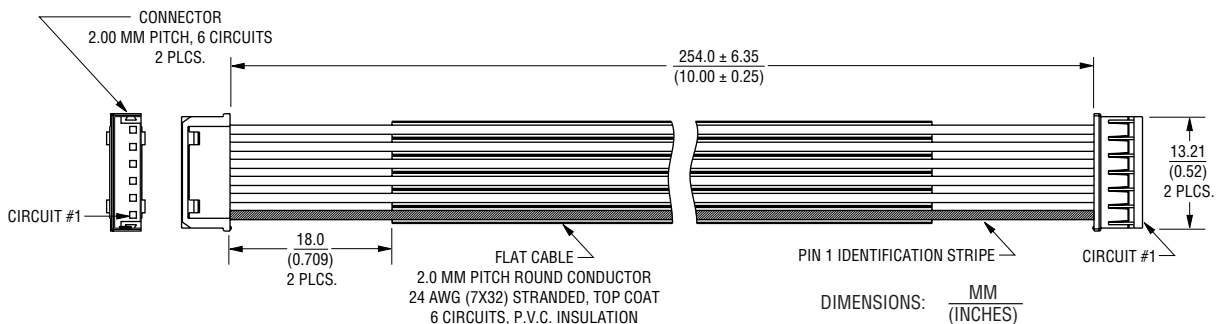

Specifications are subject to change without notice.

Users should verify actual device performance in their specific applications.

The products described herein and this document are subject to specific legal disclaimers as set forth on the last page of this document, and at [www.bourns.com/docs/legal/disclaimer.pdf](http://www.bourns.com/docs/legal/disclaimer.pdf).

# EMS22A - Non-Contacting Absolute Encoder

**BOURNS®**

## How To Order

