

Features

- 3.3 and 5 VDC voltage supply option
- PWM Absolute Position
- Bushing or servo mount
- Non-contacting magnetic technology
- Small size
- CMOS and TTL compatible
- Resolution: 1024 states
- Long life
- High operating speed
- Highly repeatable
- Sealed option
- Magnetic technology

EMS22P - Non-Contacting PWM Encoder

Electrical Characteristics

Resolution	1024 states
Insulation Resistance (500 VDC)	1,000 megohms
Electrical Travel	Continuous
Supply Voltage	5.0 VDC $\pm 10\%$, 3.3 VDC $\pm 10\%$
Supply Current	20 mA maximum
Output Voltage	
Low Output Level	Vss+0.4 V maximum
High Output Level	Vdd-0.5 V minimum
Output Current	
With 4.5 VDC Supply Voltage	4 mA maximum
With 3.0 VDC Supply Voltage	2 mA maximum
Rise/Fall Time (Incremental Output)	500 ns maximum
Shaft RPM (Ball Bearing)	10,000 rpm maximum
Linearity	0.5 %
Accuracy	
Nominal	$\pm 0.7^\circ$ or better
Worst Case	$\pm 1.4^\circ$
Output Transition Noise	0.12 $^\circ$ RMS max.

Environmental Characteristics

Operating Temperature Range	-40 $^\circ$ C to +125 $^\circ$ C (-40 $^\circ$ F to +257 $^\circ$ F)
Storage Temperature Range	-55 $^\circ$ C to +125 $^\circ$ C (-67 $^\circ$ F to +257 $^\circ$ F)
Humidity	MIL-STD-202, Method 103B, Condition B
Vibration	15 G
Shock	50 G
Rotational Life	
S Bushing (@1,000 rpm)	100,000,000 revolutions
T & W Bushings (@1,000 rpm with 250 g side load)	50,000,000 revolutions
IP Rating	IP 65

Mechanical Characteristics

Mechanical Angle	360 $^\circ$ Continuous
Torque	
Starting	43 ± 21 g-cm (0.6 ± 0.3 oz-in.)
Running	29 ± 14 g-cm (0.4 ± 0.2 oz-in.)
Mounting Torque	203 N-cm (18 lb.-in.)
Shaft End Play	0.30 mm (0.012 ") T.I.R. maximum
Shaft Radial Play	0.12 mm (0.005 ") T.I.R. maximum
Weight	11 gms. (0.4 oz.)
Terminals	Axial, radial or ribbon cable
Soldering Condition	
Manual Soldering	96.5Sn/3.0Ag/0.5Cu solid wire or no-clean rosin cored wire 370 $^\circ$ C (700 $^\circ$ F) max. for 3 seconds
Wave Soldering	96.5Sn/3.0Ag/0.5Cu solder with no-clean flux 260 $^\circ$ C (500 $^\circ$ F) max. for 10 seconds
Wash processes	Not recommended
Marking	Manufacturer's trademark, name, part number, and date code.
Hardware	One lockwasher and one mounting nut supplied with each encoder, except on servo mount versions.

Pin Configuration

Output Type	Pin 1	Pin 2	Pin 3	Pin 4	Pin 5	Pin 6
PWM	PWM Signal	GND	GND	GND	VCC*	CS**

* Can be 5 or 3.3 VDC depending on the version.

** Active low chip select pin; if not used connect pin 6 to GND.



WARNING Cancer and Reproductive Harm - www.P65Warnings.ca.gov

*RoHS Directive 2015/863, Mar 31, 2015 and Annex.

Specifications are subject to change without notice.

Users should verify actual device performance in their specific applications.

The products described herein and this document are subject to specific legal disclaimers as set forth on the last page of this document, and at www.bourns.com/docs/legal/disclaimer.pdf.

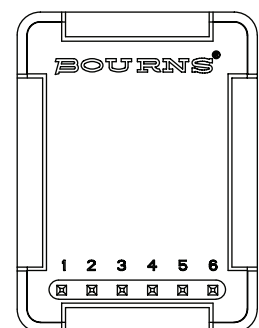

Applications

- Material handling equipment
- Brushless DC motor commutation
- Robotics
- Automotive
- Industrial automation
- Petroleum refinery
- Medical (low/medium risk)*
- Office equipment
- Audio and broadcast equipment

EMS22P - Non-Contacting PWM Encoder

BOURNS®

Output Type Waveform and Variant Table

PWM Output

Parameter	Symbol	Type	Unit	Note
PWM frequency	fPWM	0.9756	KHz	Signal period: 1025 μ s
MIN pulse with	PWMIN	1	μ s	Position 0 Angle 0°
MAX pulse with	PWMAX	1024	μ s	Position 1023 Angle 359.65°

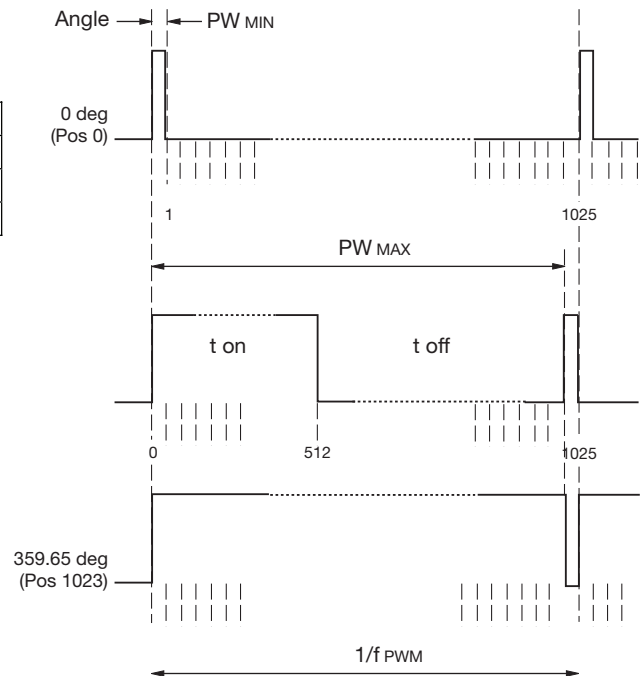
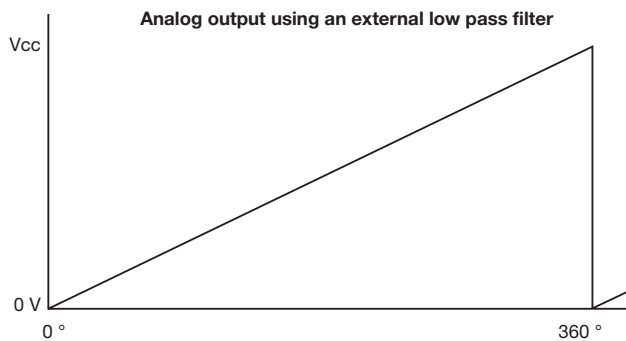

$$\text{Position} = t_{on} * 1025 / (t_{on} + t_{off}) - 1$$

Recommended Filter

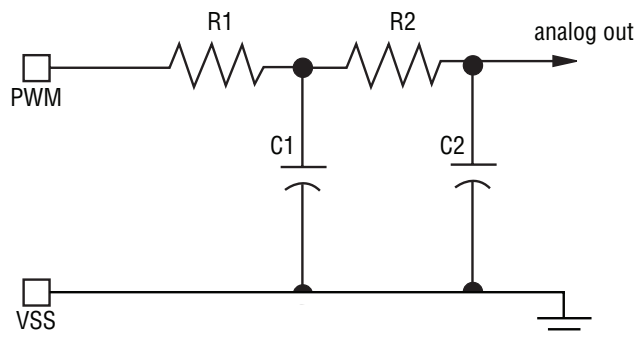

$$R1, R2 \geq 4.7K \text{ Ohms} \quad C1, C2 \geq 1 \mu F / 6 V$$

R1 should be $\geq 4.7K$ ohms to avoid loading of the PWM output. Larger values of R_x and C_x will provide better filtering and less ripple, but will also slow down the response time.

* Bourns® products have not been designed for and are not intended for use in "lifesaving," "life-critical" or "life-sustaining" applications nor any other applications where failure or malfunction of the Bourns® product may result in personal injury or death. See Legal Disclaimer Notice www.bourns.com/docs/legal/disclaimer.pdf.

Specifications are subject to change without notice. Users should verify actual device performance in their specific applications.

The products described herein and this document are subject to specific legal disclaimers as set forth on the last page of this document, and at www.bourns.com/docs/legal/disclaimer.pdf.

Consult factory for options not shown, including:

- Wire lead or cable options
- Connectors
- Non-standard resolutions
- Special shaft/bushing sizes and features
- Special performance characteristics
- PCB mounting bracket

EMS22P - Non-Contacting PWM Encoder

BOURNS®

Product Dimensions

Shaft Style D (Bushing T)

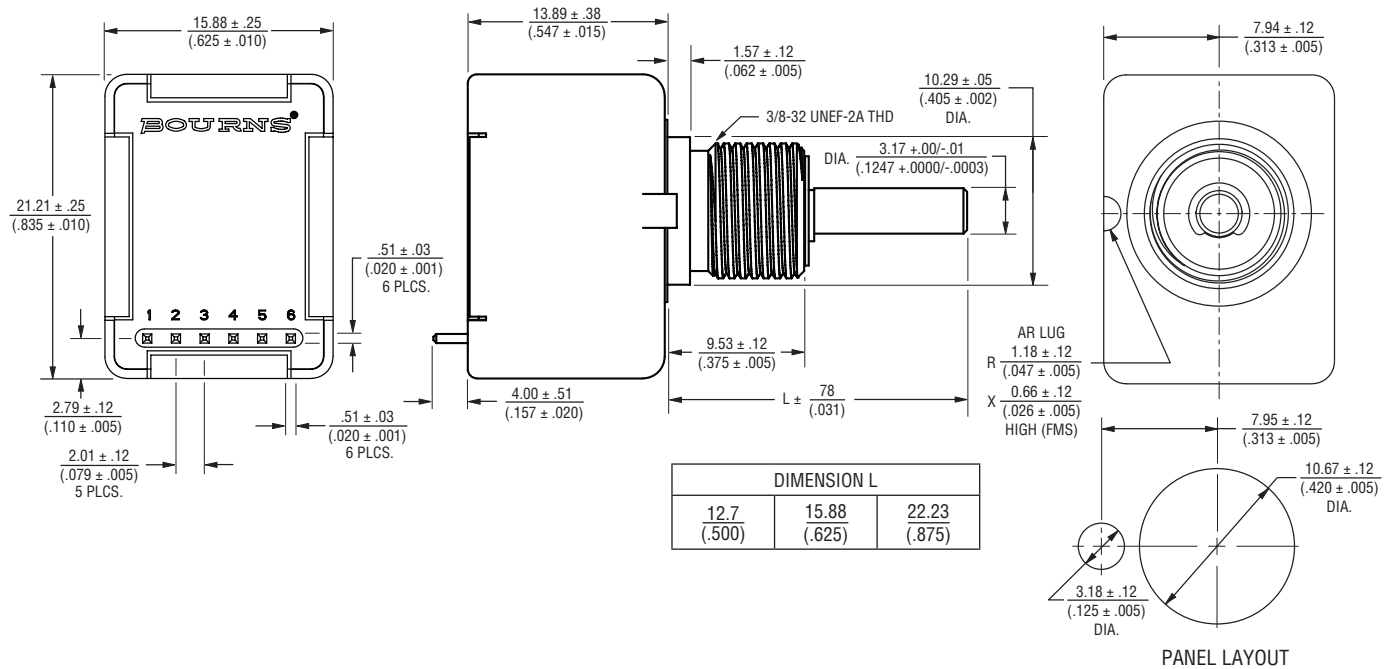

Shaft Style B (Bushing S)

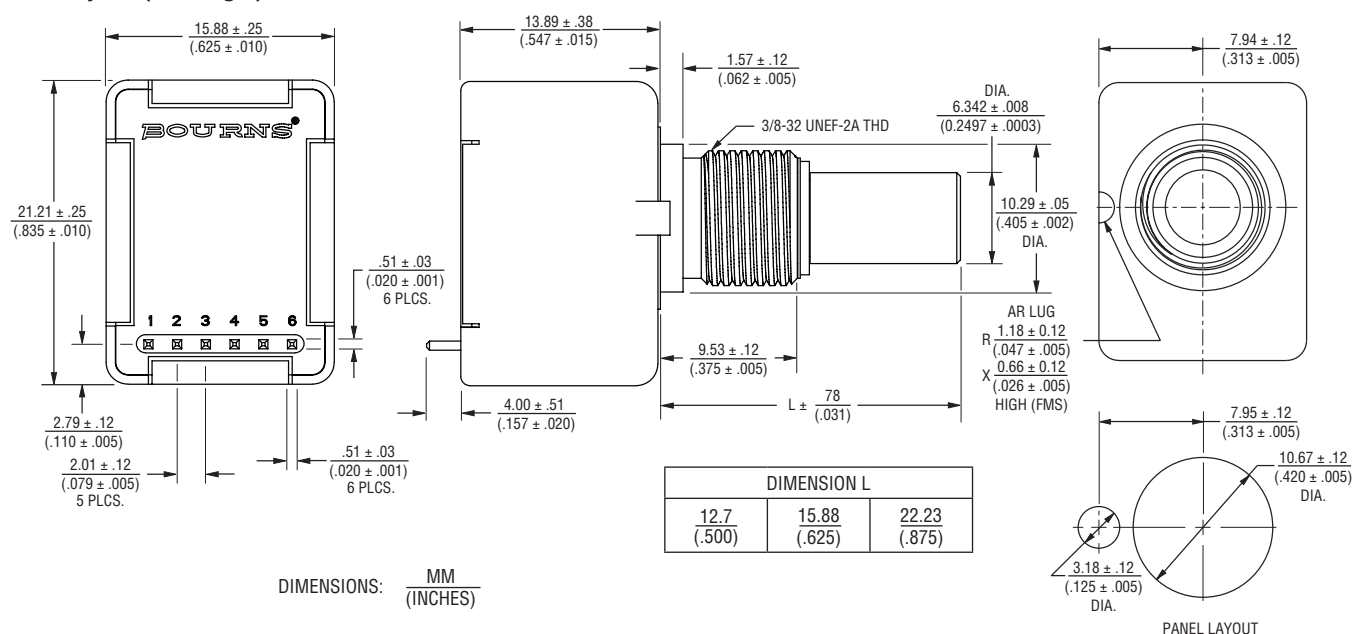

Specifications are subject to change without notice.

Users should verify actual device performance in their specific applications.

The products described herein and this document are subject to specific legal disclaimers as set forth on the last page of this document, and at www.bourns.com/docs/legal/disclaimer.pdf.

EMS22P - Non-Contacting PWM Encoder

BOURNS®

Product Dimensions (Continued)

Shaft Style D (Bushing W)

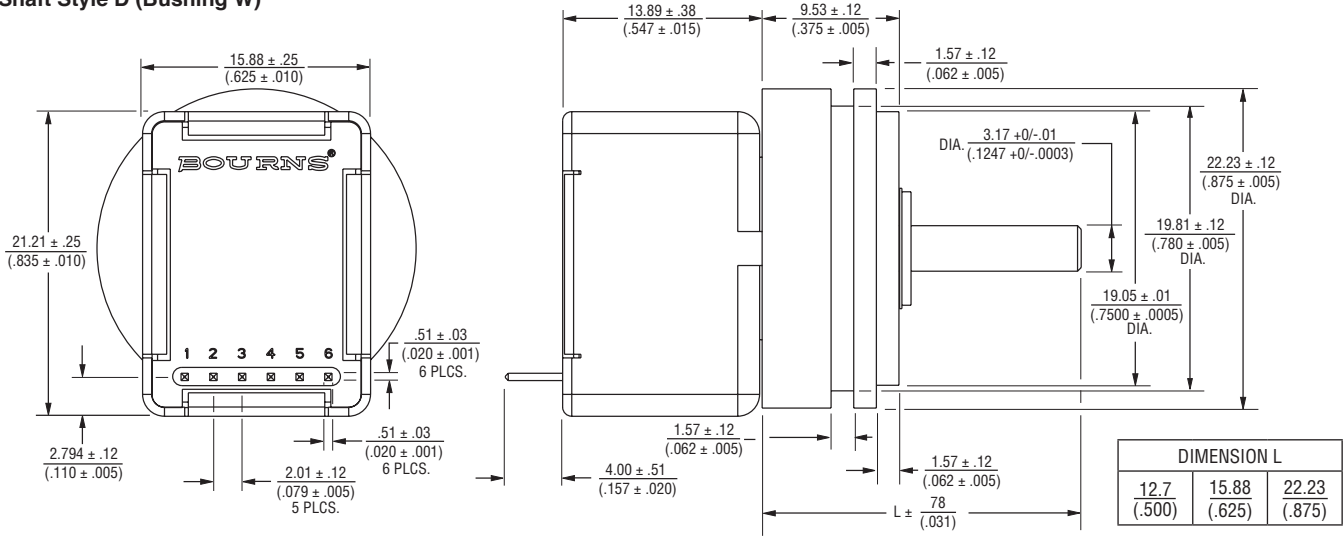

Shaft Style C (Bushing S)

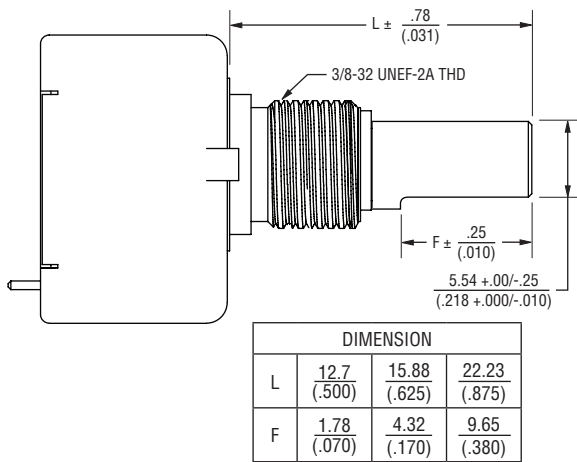

Shaft Style M (Bushing D)

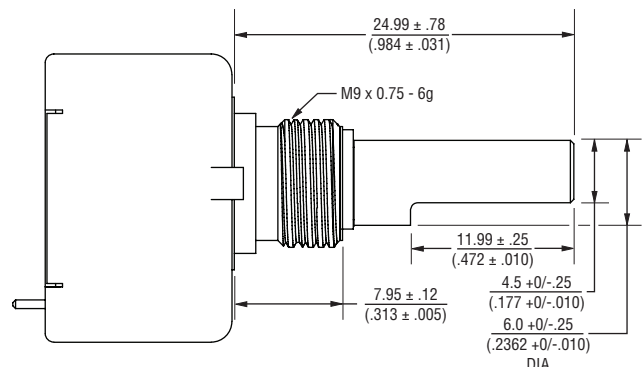

Cable Assembly

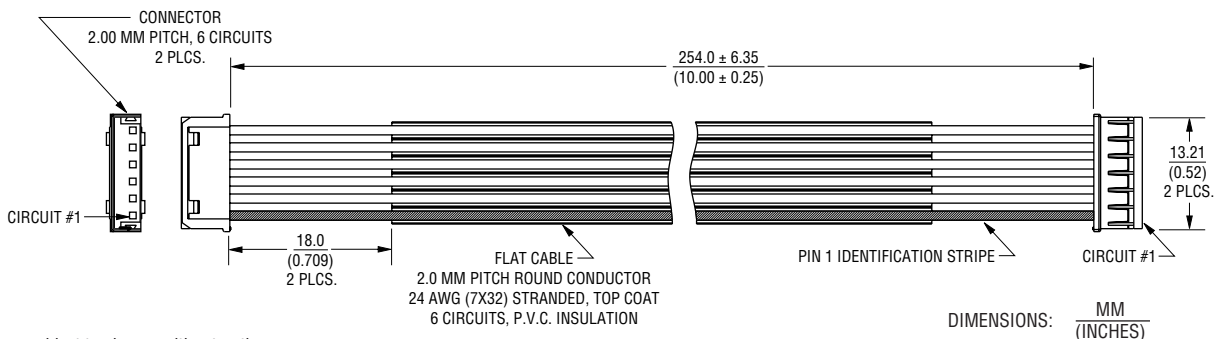

Specifications are subject to change without notice.

Users should verify actual device performance in their specific applications.

The products described herein and this document are subject to specific legal disclaimers as set forth on the last page of this document, and at www.bourns.com/docs/legal/disclaimer.pdf.

EMS22P - Non-Contacting PWM Encoder

BOURNS®

How To Order

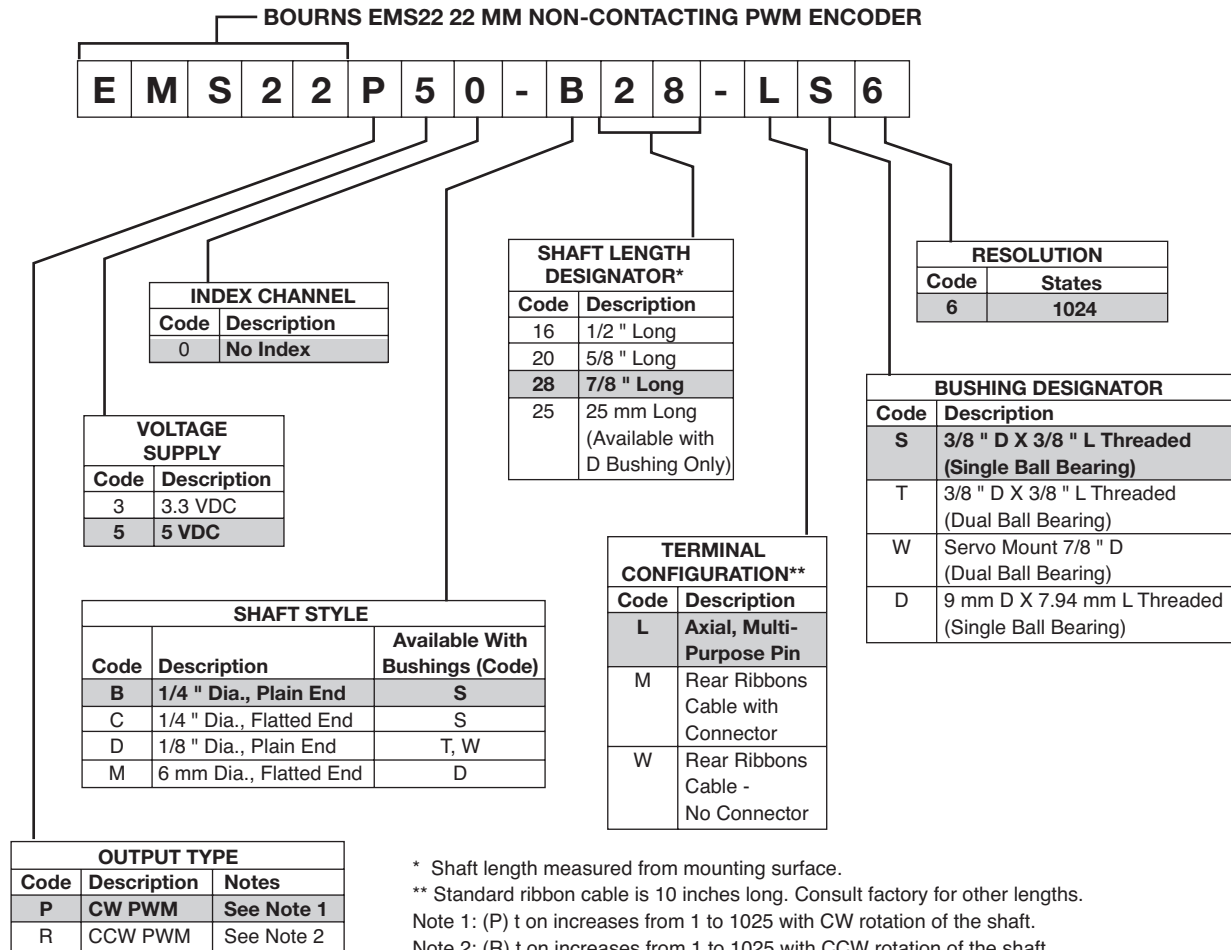

REV. 06/20

Specifications are subject to change without notice.

Users should verify actual device performance in their specific applications.

The products described herein and this document are subject to specific legal disclaimers as set forth on the last page of this document, and at www.bourns.com/docs/legal/disclaimer.pdf.