

EP5250HPHVM1-2

Power Application Controllers

EP5250HPHVM1-2 User's Guide



www.active-semi.com

CONTENTS

- Contents2
- Overview3
- EP5250HPHVM1-2 Resources5
 - Pinout and Signal Connectivity.....5
 - Power Input6
 - LED's6
 - SWD Debugging7
 - Serial Communications.....7
 - Hall Sensor / PWM DAC Interface7
 - Standalone PWM DAC Interface.....7
 - Hall Sensor / PWM DAC Interface (Continued).....8
- EP5250HPHVM1-2 Setup9
- About Active-Semi..... 10

OVERVIEW

Active-Semi's EP5250HPHVM1-2 development platform is a complete hardware solution enabling users not only to evaluate the PAC5250 device, but also develop power applications revolving around this powerful and versatile Cortex M0 based microcontroller. The module contains a PAC5250 Power Application Controller (MCU) and all the necessary circuitry to properly energize the MCU and its internal peripherals once power is applied.

To aid in the application development the EP5250HPHVM1-2 offers access to each and every one of the PAC5250 device's signals by means of a series of female header connectors.

The EP5250HPHVM1-2 also contains access to an external USB to UART module enabling users to connect the evaluation module to a PC computer through a conventional Virtual Comm Port which can then be used in the communication efforts by taking advantage of the PAC5250's UART interface. Graphical User Interface (GUI) software suites can be employed to externally control particular application's features.

Finally, the EP5250HPHVM1-2 module gives access to the PAC5250's SWD port allowing users to both program their application into the device's FLASH memory, as well as debugging the application in real time. The 4 pin connector based SWD port is compatible with a fair number of debugger/programmer modules widely available.

Active-Semi's EP5250HPHVM1-2 evaluation kit consists of the following:

- EP5250HPHVM1-2 Evaluation module
- EP5250HPHVM1-2 User's Guide
- Schematics, BOM and Layout Drawings

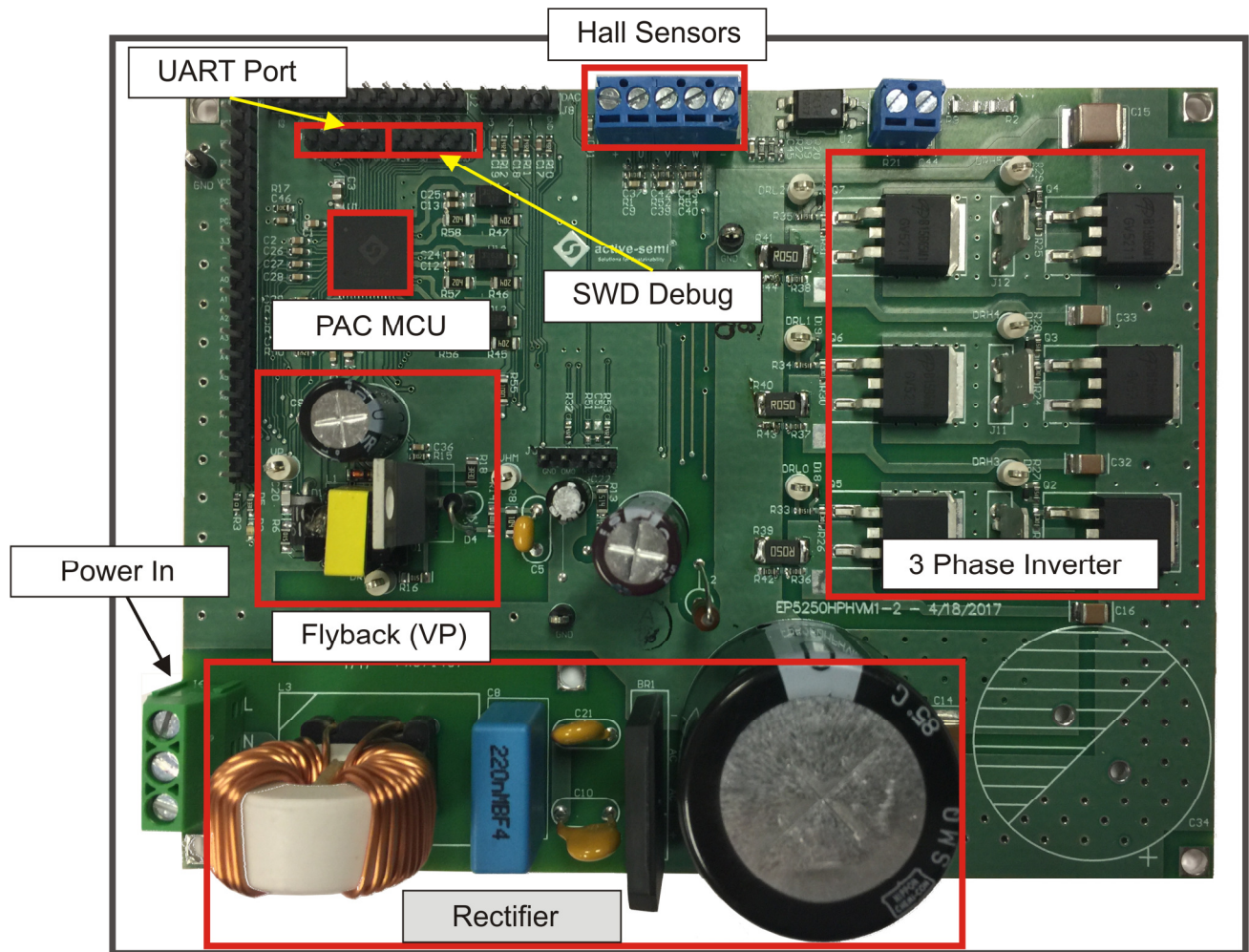

Figure 1: EP5250HPHM1-2 Block Diagram

Solution Benefits:

- Ideal for High Voltage (220 VAC nominal, up to 450VDC Abs Max) general purpose power applications and controllers
- Single-IC PAC5250 with 14 PWM outputs, 9 ADC inputs, I2C, UART, SPI and GPIO.
- Gate driving for up to three half H Bridge (tri phase) inverter.
- Three PWM DAC's for real time debugging.
- Hall Sensor Interface for sensed applications.
- Current and Voltage sensing for sensorless applications.
- Schematics, BOM, Layout drawings available

The following sections provide information about the hardware features of Active-Semi's EP5250HPHM1-2 turnkey solution.

EP5250HPHVM1-2 RESOURCES

Pinout and Signal Connectivity

The following diagram shows the male header pinout for the EP5250HPHVM1-2 evaluation module, as seen from above:

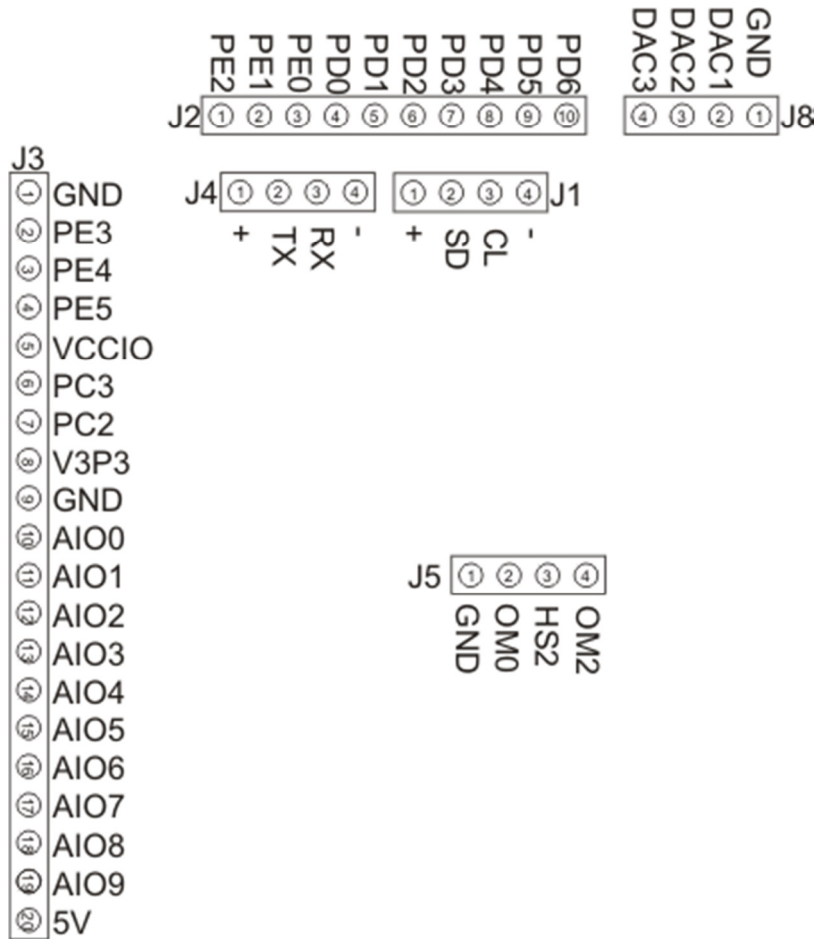

Figure 2 EP5250HPHVM1-2 Headers and Test Stakes Pinout

Power Input

Power to the EP5250HPHVM1-2 evaluation module can be applied to the J6 three position terminal block connector. Power to the EP5250HPHVM1-2 evaluation module should not exceed 240 VAC (450 VDC Abs Max).

The EP5250HPHVM1-2 is optimized to operate with voltages ranging from 110 VAC to 220 VAC Nominal. When the rectified input voltage (VBUS) goes above around 120 VDC, the system's Fly Back Power Controller is powered up and the device exits UVLO protection. At this time all subsystems, including internal voltage regulators, analog front end and microcontroller, are enabled.

LED's

When an operational voltage is applied, LED D2 will light up. This is the LED which notifies VSYS (5V) rail is up and running. VP (12V gate drive), 3.3V (for analog circuitry) and 1.8V (for CPU core) regulators will also be operating at this point in time. Module is ready for use.

The following table shows the provided LED and its associated diagnostic function.

LED	Description
D2	VSYS (5V). Light up when the PAC5250 device is successfully powered up by VIN.

SWD Debugging

Connector J1 offers access to the PAC5250 SWD port lines.

J1 Pin	Terminal	Description
1	+	VCCIO (default is 5V)
2	SD	SWD Serial Data
3	CL	SWD Serial Clock
4	-	GND (System Ground)

Serial Communications

Connector J4 offers access to the PAC5250 UART port lines.

J4 Pin	Terminal	Description
1	+	VCCIO (default is 5V)
2	TX	MCU Transmit Line
3	RX	MCU Receive Line
4	-	GND (System Ground)

Hall Sensor / PWM DAC Interface

Connector J15 offers access to the PAC5250 resources on PORTD utilized for hall sensor based commutation. These resources can be alternatively utilized as PWM DAC outputs for in real time debugging.

J15 Pin	Terminal	Description
1	+	VCCIO (default is 5V)
2	Hall Sensor U	PORTD2 (PWMB0 function)
3	Hall Sensor V	PORTD3 (PWMB1 function)
4	Hall Sensor W	PORTD7 (PWMD0 function)
5	GND	GND (System Ground)

Standalone PWM DAC Interface

Connector J8 offers access to three PAC5250 DRL3/4/5 outputs which have been reconfigured to operate as PWM DAC's. These outputs can then be utilized to provide real time information while executing motion control code.

J8 Pin	Terminal	Description
1	GND	GND (System Ground)
2	PWM DAC 1	DRL3 (PWMB0 function)
3	PWM DAC 2	DRL4 (PWMC0 function)
4	PWM DAC 3	DRL5 (PWMD0 function)

Hall Sensor / PWM DAC Interface (Continued)

The EP5250HPHVM1-2 module is built with the six capacitors populated (C25, C26, C27, C28, C29, C31). Depending on the interface to be utilized, the user should remove a set of three capacitors as shown below:

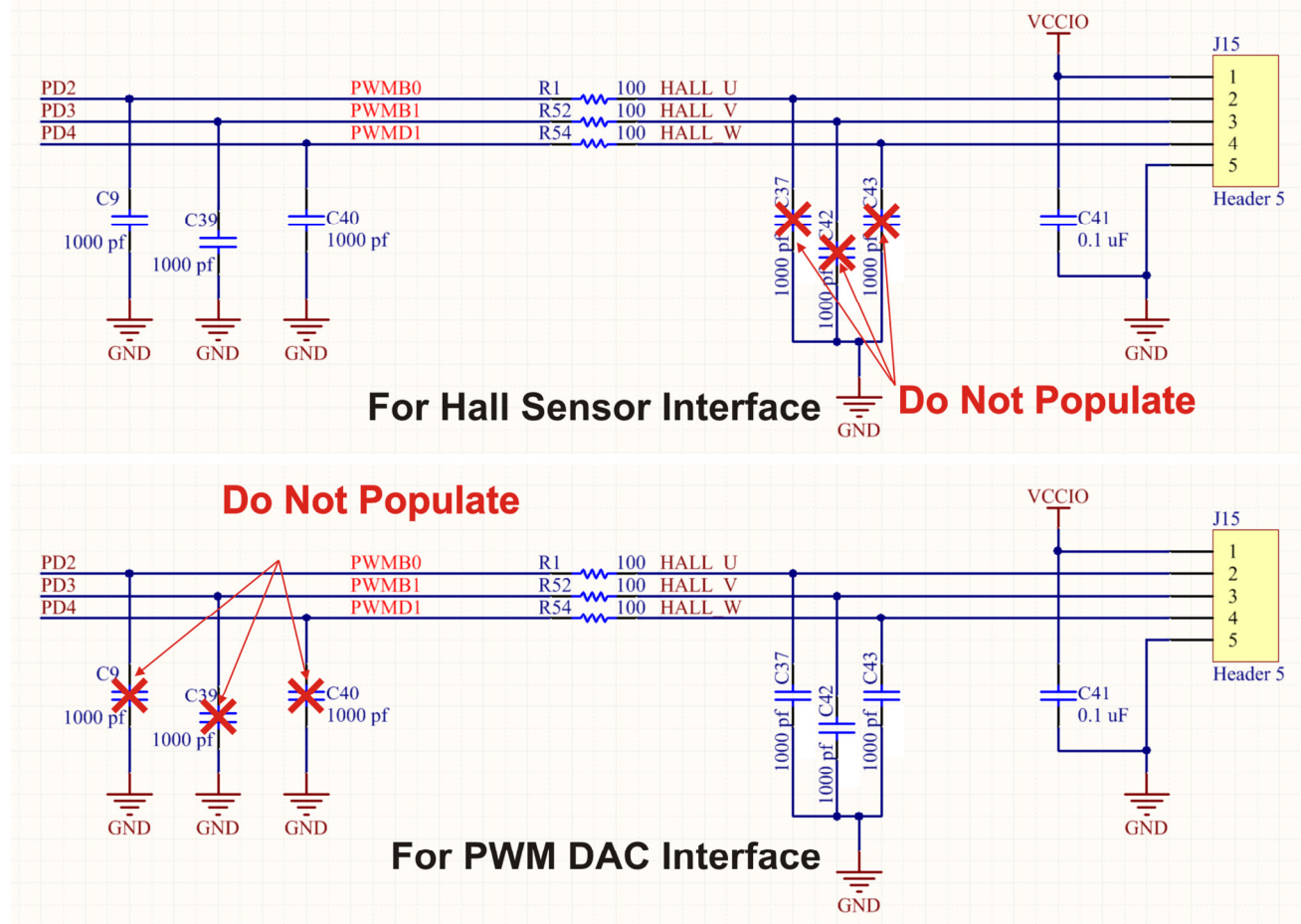

Figure 7: Hall Sensor / DAC Interface Component Selection

NOTE: User may also prefer to change the three resistors (R1, R52, R54) and three capacitors (C37, C42, C43) values depending on the employed PWM frequency. For provided FW default frequencies, 4.3K resistors and 0.1 uF ceramic capacitors have been tested to provide desirable results.

EP5250HPHVM1-2 SETUP

The setup for the EP5250HPHVM1-2 evaluation module requires up to four simple connections.

1. Connect the 3 Phase BLDC/PMSM motor via space tab connectors PHASE U, PHASE V and PHASE W.
2. If Serial Communications are desired, connect the USB to UART module 4 pin connection to J4.
3. For debugging/programming, connect a suitable USB SWD module to J1 by using a standard 4 wire cable.
4. Connect the line voltage power source via three prong terminal block connector J6. For most systems, only connecting to the Live and Neutral terminals is sufficient.
5. **NOTE:** Due to the high voltage nature of this board, it is highly recommended for all connections to be made prior to applying power. Once rectified input voltage goes above 120VDC, the PAC5250's Multi Mode Power Manager will be engaged and the VSYS (5V) regulator will be enabled. This event will result in LED D2 lighting up.

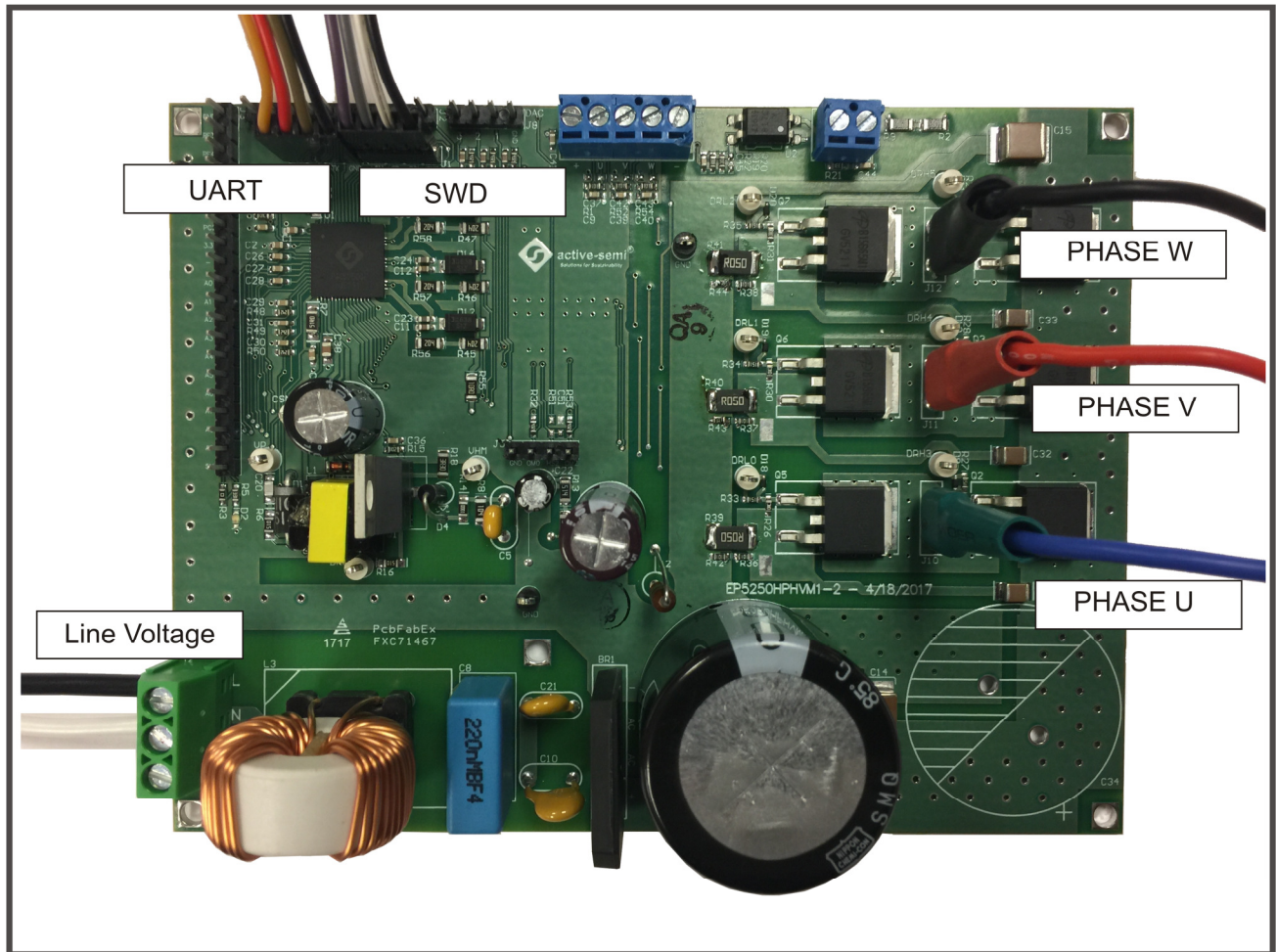

Figure 7: EP5250HPHVM1-2 Evaluation Module Connections