

Features

- RoHS compliant*
- HCMOS, CMOS and TTL compatible
- Compact package size
- High rotational cycle life
- Ball bearing shaft support
- Recommended for machine/machine interface applications (MMI)



ES14 - 14 mm Rotary Optical Encoder

Electrical Characteristics

Electrical Output	2-bit quadrature code
Resolution	8 to 64 pulses per revolution (PPR)
Supply Voltage (VCC)	5.0 VDC \pm 0.25 VDC
Supply Current (ICC)	26 mA maximum
Output Voltage	
Low (VCE(sat)), per Channel	800 mV maximum at I(SINK) = 25 mA
High (VO(HI)), per Channel	4.0 VDC minimum @ VCC = 4.75 VDC
Output Current I(SINK), per Channel	25 mA minimum
Rise/Fall Time	200 ns typical
Power Dissipation	167 mW maximum
Pulse Width (per Channel)	180 °e typical
Phase Angle (Channel A Leads Channel B, Clockwise Rotation)	90 °e \pm 72 °e
Insulation Resistance @ 500 VDC	1,000 megohms minimum
Operating RPM	1000 maximum

Environmental Characteristics

Operating Temperature Range @ 5.0 VDC	-40 °C to +70 °C (-40 °F to +158 °F)
Storage Temperature Range	-55 °C to +125 °C (-67 °F to +257 °F)
Vibration	15 G
Shock	50 G
Humidity	MIL-STD-202, Method 103, Condition B
Flammability	Conforms to UL 94HB
IP Rating	IP 54**

Mechanical Characteristics

Mechanical Angle	360 ° Continuous
Torque	
Starting/Running	1.05 N-mm (0.15 oz.-in.) maximum
Rotational Life	50,000,000 cycles (100,000,000 revolutions)
Shaft Radial Play	0.003 in. maximum
Shaft Axial Structural Strength	35 lbs. minimum
Mounting Torque	2.0 N-m (18 lb.-in.) maximum

Materials and Finishes

Terminals	Sn plated PC pins
Soldering Condition	
Manual Soldering	96.5Sn/3.0Ag/0.5Cu solid wire or no-clean rosin cored wire 370 °C (700 °F) max. for 3 seconds
Wave Soldering	96.5Sn/3.0Ag/0.5Cu solder with no-clean flux 260 °C (500 °F) max. for 5 seconds
Wash processes	Not recommended
Mounting Hardware	
Nut	Brass, hex (metric)/Nickel-plated brass, hex (SAE)
Lockwasher	Nickel-plated spring steel, internal tooth
Marking	Manufacturer's symbol, model number, product code, terminal style and date code
Standard Packaging	Anti-static plastic tube (25 pcs./tube)

**When device is mounted by normal mounting means.



WARNING
Cancer and Reproductive Harm
www.P65Warnings.ca.gov

*RoHS Directive 2015/863, Mar 31, 2015 and Annex.

Specifications are subject to change without notice. Users should verify actual device performance in their specific applications. The products described herein and this document are subject to specific legal disclaimers as set forth on the last page of this document, and at www.bourns.com/docs/legal/disclaimer.pdf

Additional Features

- Cable/connector option
- Optional bracket

ES14 - 14 mm Rotary Optical Encoder

BOURNS®

Part Numbering System

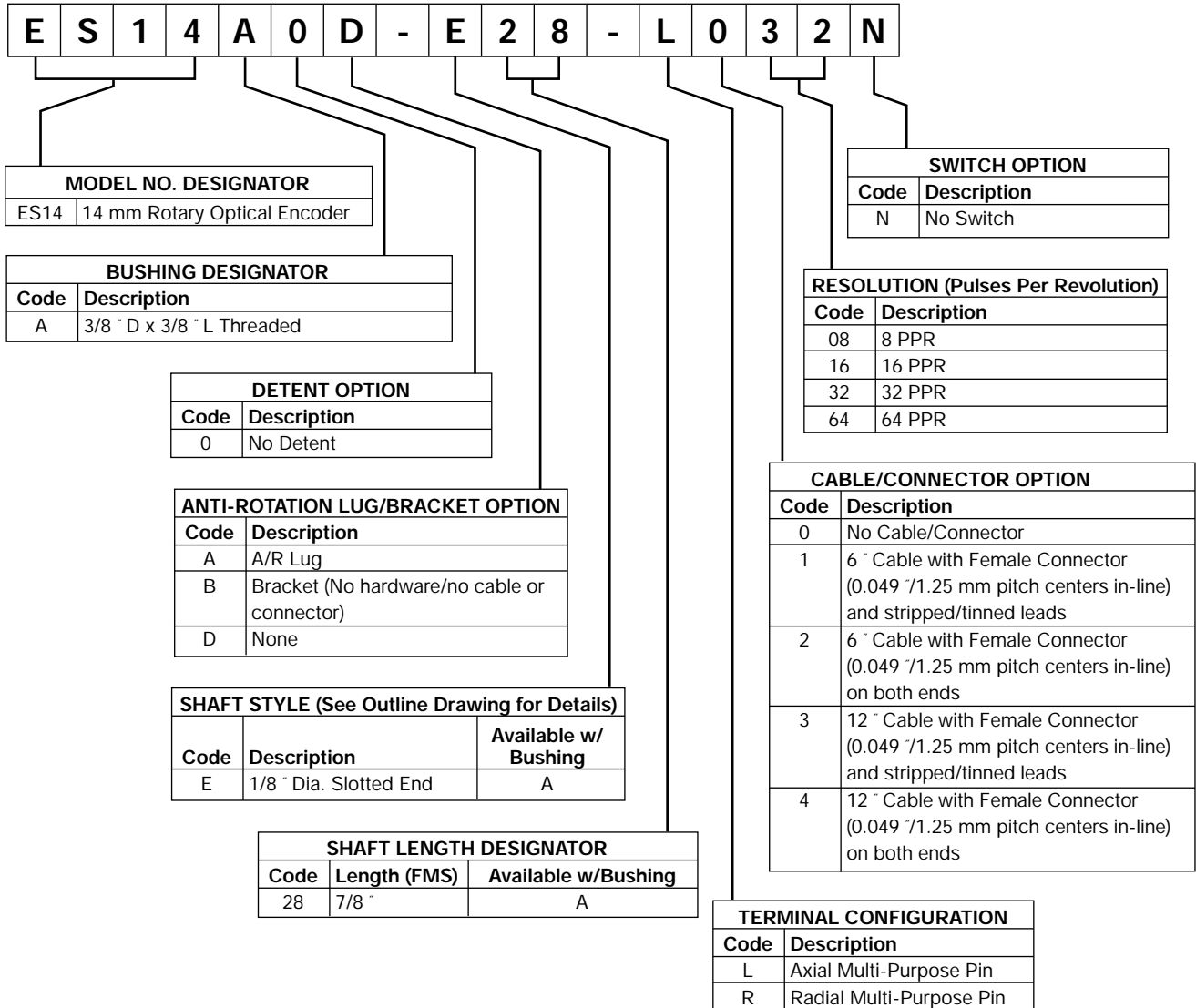

Cable and Connector Options:

- H-290-4 = 6" Cable with Female Connector (0.049" /1.25 mm pitch centers in-line) and stripped/tinned leads
- H-290-1 = 6" Cable with Female Connector (0.049" /1.25 mm pitch centers in-line) on both ends
- H-290-2 = 12" Cable with Female Connector (0.049" /1.25 mm pitch centers in-line) and stripped/tinned leads
- H-290-3 = 12" Cable with Female Connector (0.049" /1.25 mm pitch centers in-line) on both ends

For other cable and connector options, please contact the factory.

Specifications are subject to change without notice.

Users should verify actual device performance in their specific applications.

The products described herein and this document are subject to specific legal disclaimers as set forth on the last page of this document, and at www.bourns.com/docs/legal/disclaimer.pdf.

ES14 - 14 mm Rotary Optical Encoder

BOURNS®

Product Dimensions

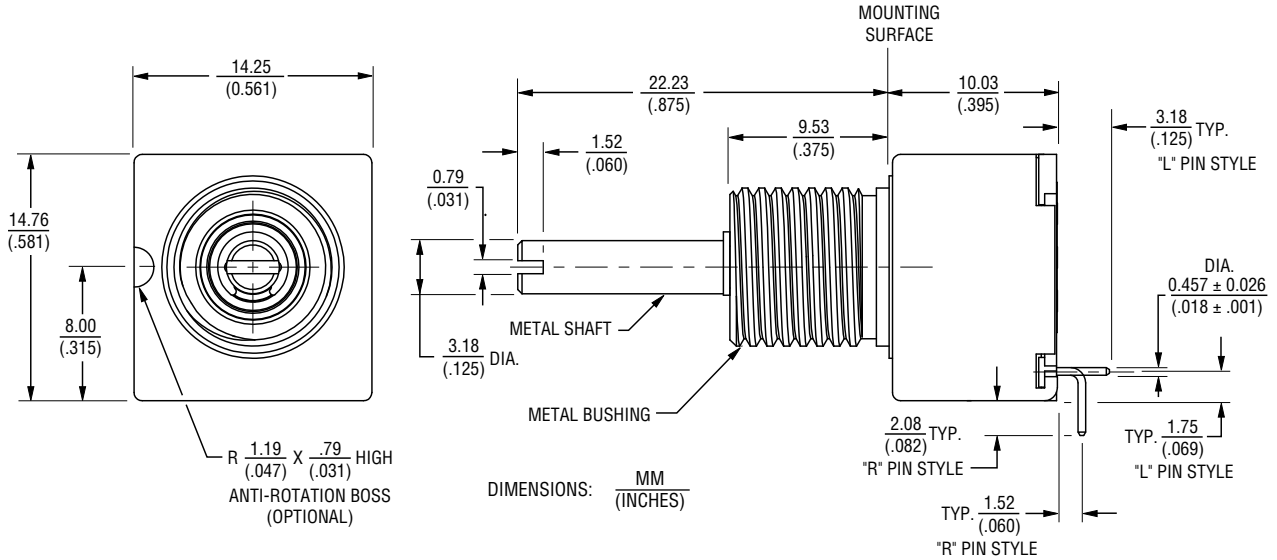

Cable/Connector Options

Cable Assembly, Connector on One End

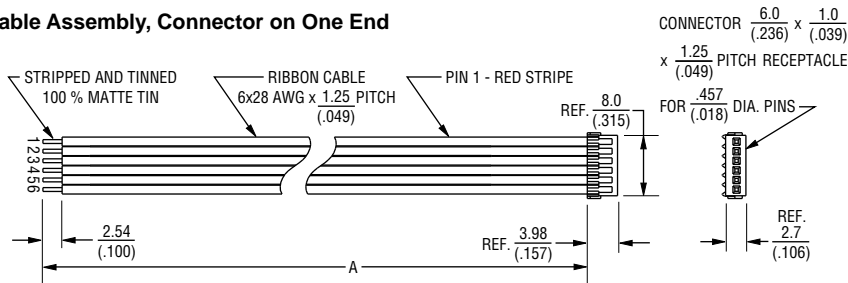

Cable Assembly, Connector on Both Ends

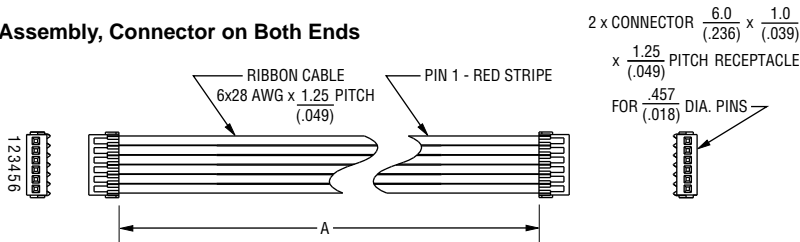

HARDWARE NUMBER	DESCRIPTION	"A" DIM.
H-290-4	CABLE ASSEMBLY, CONNECTOR ON ONE END	152.4 ± 5.0 (6.0 ± .197)
H-290-2	CABLE ASSEMBLY, CONNECTOR ON ONE END	304.8 ± 5.0 (12.0 ± .197)
H-290-1	CABLE ASSEMBLY, CONNECTOR ON BOTH ENDS	152.4 ± 5.0 (6.0 ± .197)
H-290-3	CABLE ASSEMBLY, CONNECTOR ON BOTH ENDS	304.8 ± 5.0 (12.0 ± .197)

DIMENSIONS: MM (INCHES)

ES14 - 14 mm Rotary Optical Encoder

BOURNS®

Terminal Configurations

Radial (shown with optional mounting bracket)

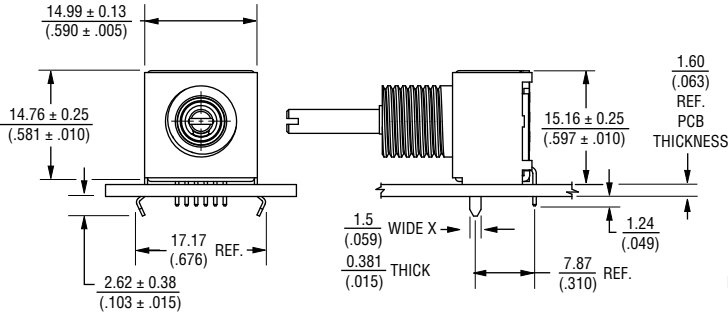

Recommended PCB Layout

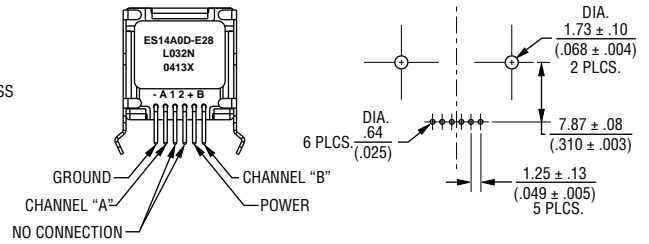

Axial (shown with optional mounting bracket)

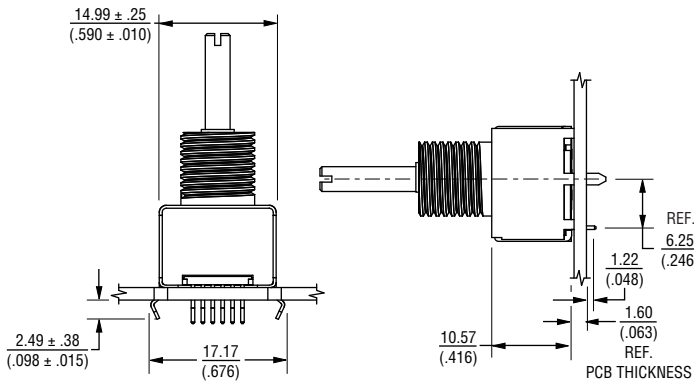

Recommended PCB Layout

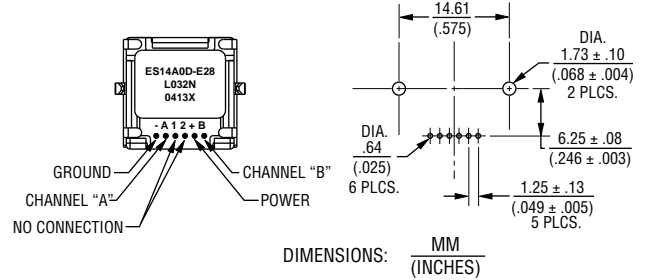

Terminal Diagram

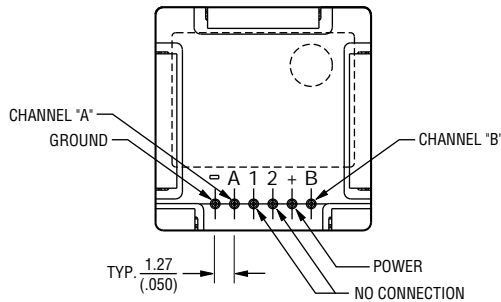

Quadrature Output

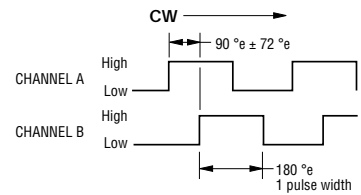

ES14 - 14 mm Rotary Optical Encoder

BOURNS®

Electrical Block Diagram

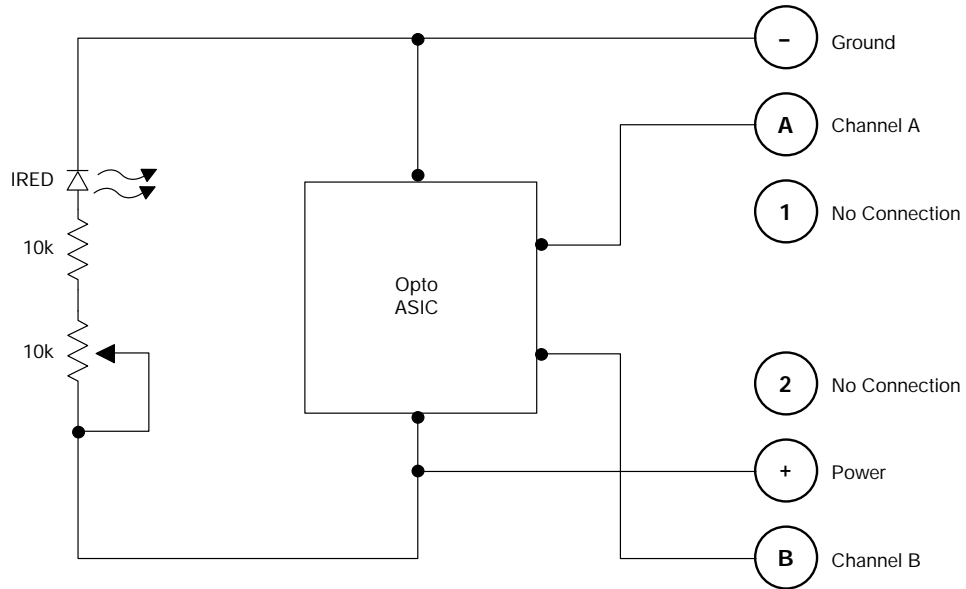

BOURNS®

Asia-Pacific: Tel: +886-2 2562-4117 • Fax: +886-2 2562-4116

EMEA: Tel: +36 88 885 877 • Fax: +36 88 520 211

The Americas: Tel: +1-951 781-5500 • Fax: +1-951 781-5700

www.bourns.com

09/19

Specifications are subject to change without notice.

Users should verify actual device performance in their specific applications.

The products described herein and this document are subject to specific legal disclaimers as set forth on the last page of this document, and at www.bourns.com/docs/legal/disclaimer.pdf.