

PoE Signal Path Transformer ^{60 W/120 W} signal path

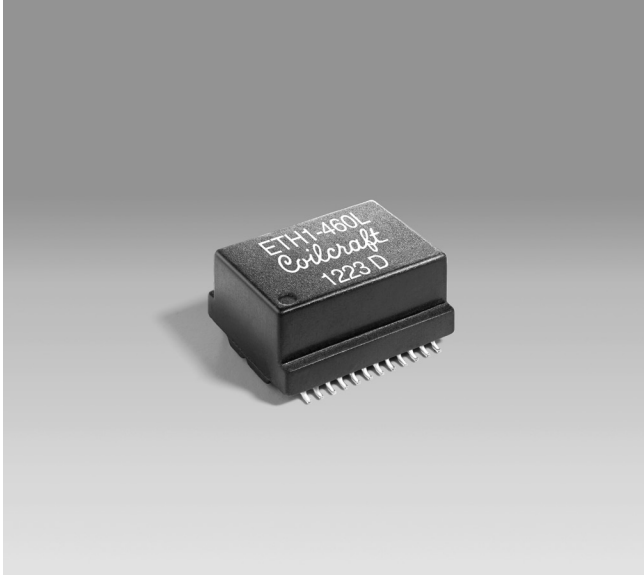

Core material Ferrite

Terminations RoHS compliant tin-silver-copper over tin over nickel over phos bronze

Weight 3.6 g

Ambient temperature -40°C to +85°C

Storage temperature Component: -40°C to +85°C.
Tape and reel packaging: -40°C to +80°C

Resistance to soldering heat Max three 40 second reflows at +260°C, parts cooled to room temperature between cycles

Moisture Sensitivity Level (MSL) 1 (unlimited floor life at <30°C / 85% relative humidity)

Failures in Time (FIT) / Mean Time Between Failures (MTBF)
60 per billion hours / 16,666,667 hours, calculated per Telcordia SR-332

Packaging 250/13" reel; Plastic tape: 32 mm wide, 0.5 mm thick, 24 mm pocket spacing, 10.6 mm pocket depth

PCB washing Tested to MIL-STD-202 Method 215 plus an additional aqueous wash. See [Doc787_PCB_Washing.pdf](#).

The **ETH1-460L**¹ is developed to meet the IEEE 802.3at-2009 and IEEE 802.3bt Type 4 standard for PoE+ and PoE++ applications. This module is designed for 4-pair cabling plants at 60 / 120 Watts. It exceeds the return loss requirements of Gbit Ethernet.

This single component solution may be used in place of two ETH1-230 parts, saving valuable board space.

It has a minimum open-circuit inductance of 350 μ H at an offset current of 35 mA at 25°C ambient temperature, and can handle 22.5 mA minimum dc offset at 85°C. Typical temperature rise from 25°C ambient is 7°C with 800 mA and 10°C with 1000 mA dc current applied to one center tap of each isolation transformer. Winding to winding isolation is 1500 Vrms. Ambient temperature range: -40°C to +85°C with 1 A current.

1. When ordering, please specify **packaging** code:

ETH1-460LD

Packaging: **D** = 13" machine-ready reel. EIA-481 embossed plastic tape. Factory order only, not stocked (250 parts per full reel).

B = Less than full reel. In tape, but not machine ready. To have a leader and trailer added (\$25 charge), use code letter D instead.

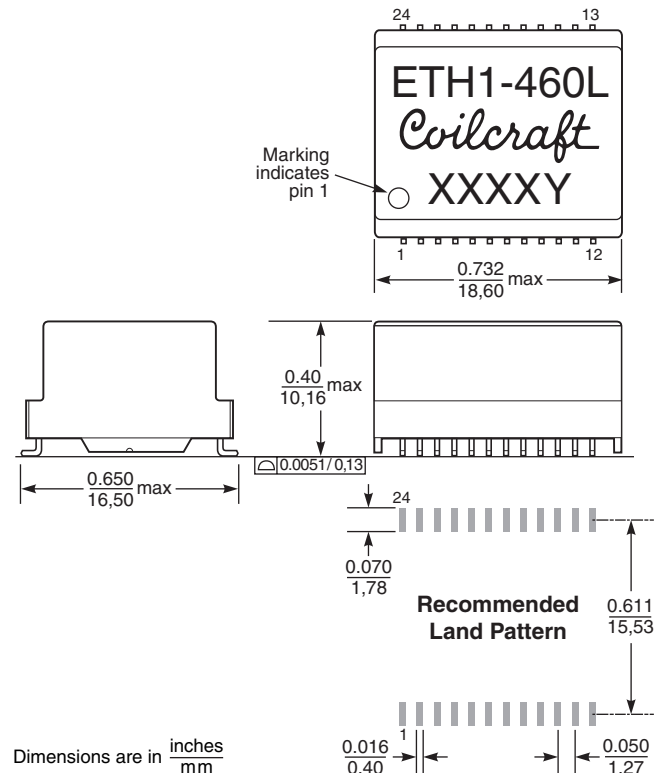



“PoE Plus” Magnetics – ETH1-460

Insertion Loss

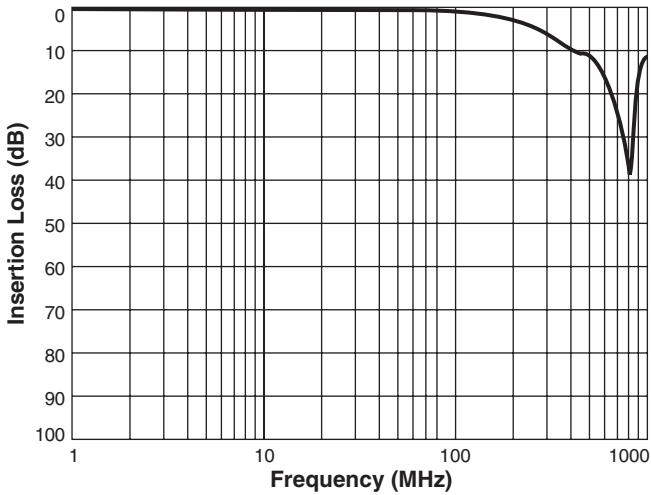

802.3af specification:
 1.0 min dB from 0.1 MHz to 100 MHz
 1.2 min dB at 125 MHz

Return Loss

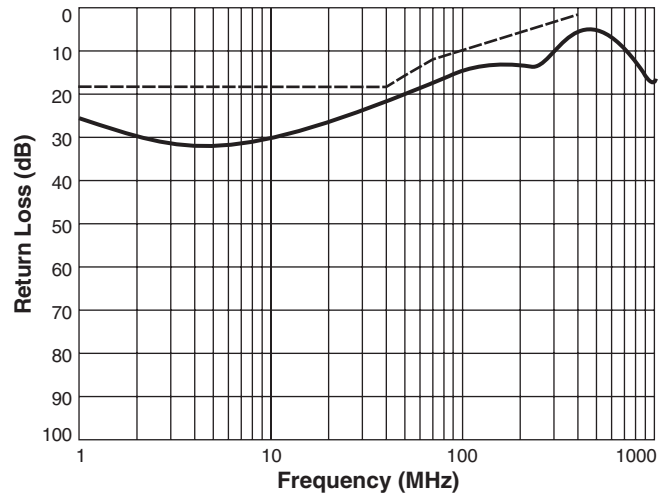

802.3af specification:
 18 dB min from 1 MHz to 40 MHz
 16 dB min at 50 MHz
 12 dB min at 80 MHz
 10 dB min at 100 MHz

L vs Offset Current

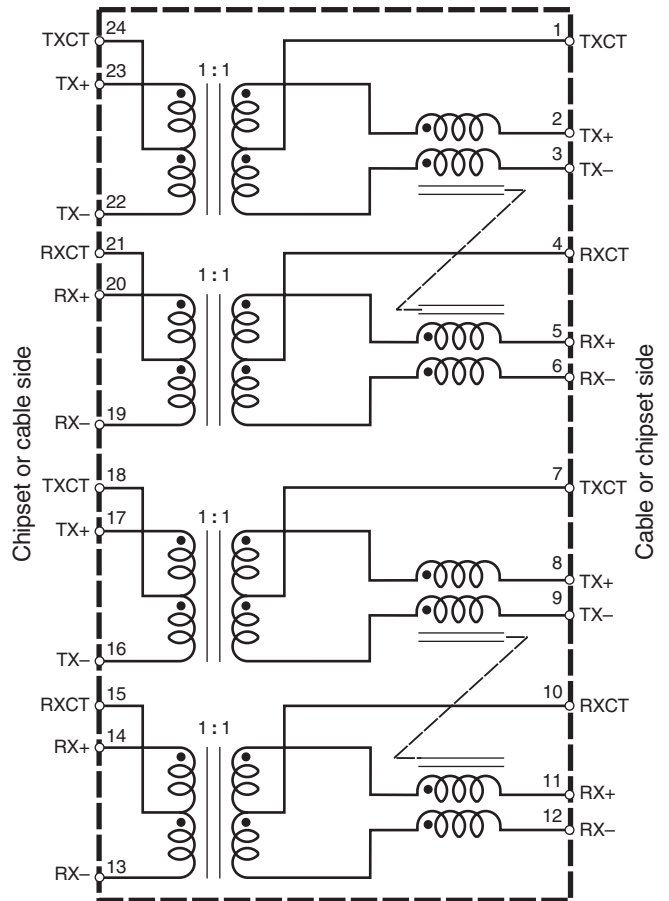
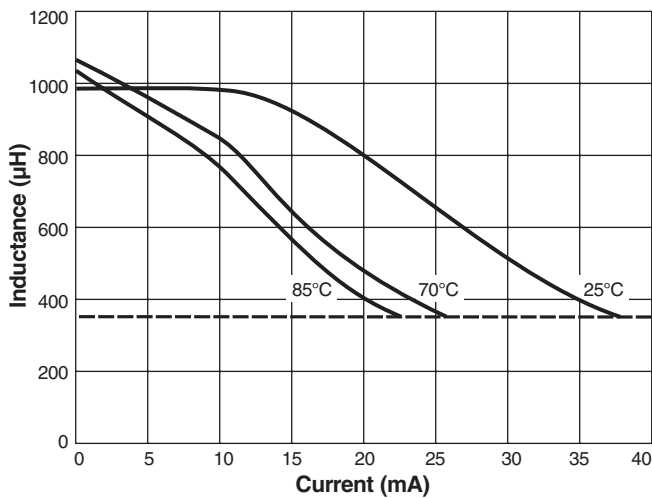

US +1-847-639-6400 sales@coilcraft.com
UK +44-1236-730595 sales@coilcraft-europe.com
Taiwan +886-2-2264 3646 sales@coilcraft.com.tw
China +86-21-6218 8074 sales@coilcraft.com.cn
Singapore + 65-6484 8412 sales@coilcraft.com.sg

Document 1008-2 Revised 10/25/18
 © Coilcraft Inc. 2018
 This product may not be used in medical or high risk applications without prior Coilcraft approval. Specification subject to change without notice. Please check web site for latest information.