

FEATURES

- EEMBC ULPMark™-CP score (3 V): 189
- Ultra low power active and hibernate modes
- Active mode dynamic current: 41 $\mu\text{A}/\text{MHz}$ (typical)
- Flexi mode: 400 μA (typical)
- Hibernate mode: 0.65 μA (typical)
- Shutdown mode: 50 nA (typical)
- Shutdown mode (fast wake-up): 0.20 μA (typical)
- ARM Cortex-M4F processor at 52 MHz with FPU, MPU, ITM with SWD interface
- Power management
- Single-supply operation (connected to VBAT pins): 1.74 V to 3.6 V
- Optional buck converter for improved efficiency
- Memory options
- 512 kB of embedded flash memory with ECC
- 4 kB of cache memory to reduce active power
- 128 kB of configurable system SRAM with parity
- Safety
 - Watchdog with dedicated on-chip oscillator
 - Hardware CRC with programmable polynomial
 - Multiparity bit protected SRAM
 - ECC protected embedded flash
- Security
 - Hardware cryptographic accelerator supporting AES-128, AES-256, and SHA-256
 - Protected key storage in flash, SHA-256-based keyed HMAC and key wrap and unwrap
 - User code protection
 - TRNG

Digital peripherals

- 3 SPI interfaces to enable glueless interface to sensors, radios, and converters
- 1 I²C and 2 UART peripheral interfaces
- SPORT for natively interfacing with converters and radios
- Programmable GPIOs (44 in LFCSP and 51 in WLCSP)
- 3 general-purpose timers with PWM support
- RGB timer for driving RGB LED
- RTC0 for time keeping
- RTC1 with SensorStrobe and time stamping
- Programmable beeper
- 27-channel DMA controller

Clocking features

- 26 MHz clock: on-chip oscillator, external crystal oscillator, SYS_CLKIN for external clock, and integrated PLL
- 32 kHz clock: on-chip oscillator and low power crystal oscillator
- Clock fail detection for external crystals

Analog peripherals

- 12-bit SAR ADC, 1.8 MSPS, 8 channels, and digital comparator

APPLICATIONS

- Internet of Things (IoT)
- Smart agriculture, smart building, smart metering, smart city, smart machine, and sensor network
- Wearables
- Fitness and clinical
- Machine learning and neural networks

FUNCTIONAL BLOCK DIAGRAM

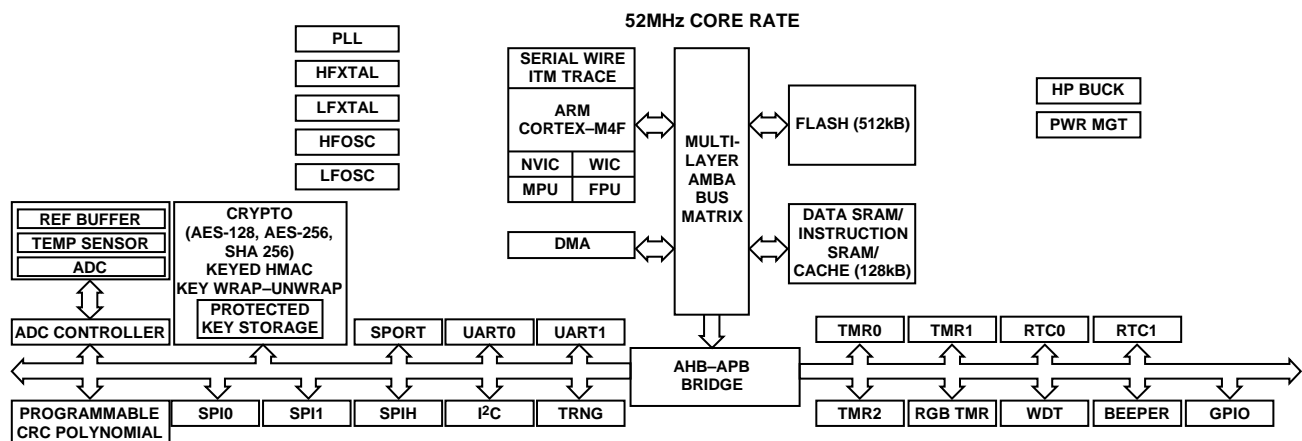

Figure 1.

TABLE OF CONTENTS

Features	1	Theory of Operation	28
Applications.....	1	ARM Cortex-M4F Processor.....	28
Functional Block Diagram.....	1	Memory Architecture	29
Revision History	2	System Integration Features.....	30
General Description	3	On-Chip Peripheral Features.....	35
Product Highlights	3	Development Support.....	36
Specifications.....	4	Reference Designs	36
Operating Conditions and Electrical Characteristics.....	4	Security Features Disclaimer	36
Embedded Flash Specifications	4	MCU Test Conditions.....	36
Power Supply Current Specifications.....	5	Driver Types.....	36
ADC Specifications	10	EEMBC ULPMark™-CP Score.....	37
Temperature Sensor Specifications	11	GPIO Multiplexing.....	38
System Clocks	12	Applications Information	40
Timing Specifications	13	Silicon Anomaly	43
Absolute Maximum Ratings.....	20	ADuCM4050 Functionality Issues.....	43
Thermal Resistance	20	Functionality Issues.....	43
ESD Caution.....	20	Section 1. ADuCM4050 Functionality Issues.....	44
Pin Configuration and Function Descriptions.....	21	Outline Dimensions	45
Typical Performance Characteristics	26	Ordering Guide	46

REVISION HISTORY

4/2019—Rev. 0 to Rev. A

Change to Crystal Equivalent Series Resistance Parameter, Table 10	12
Updated Outline Dimensions	45

6/2018—Revision 0: Initial Version

GENERAL DESCRIPTION

The ADuCM4050 microcontroller unit (MCU) is an ultra low power integrated microcontroller system with integrated power management for processing, control, and connectivity. The MCU system is based on the ARM® Cortex®-M4F processor. The MCU also has a collection of digital peripherals, embedded static random access memory (SRAM) and embedded flash memory, and an analog subsystem that provides clocking, reset, and power management capabilities in addition to an analog-to-digital converter (ADC) subsystem.

This data sheet describes the ARM Cortex-M4F core and memory architecture used on the ADuCM4050 MCU. It does not provide detailed programming information about the ARM processor.

The system features include an up to 52 MHz ARM Cortex-M4F processor, 512 kB of embedded flash memory with error correction code (ECC), an optional 4 kB cache for lower active power, and 128 kB system SRAM with parity. The ADuCM4050 features a power management unit (PMU), multilayer advanced microcontroller bus architecture (AMBA) bus matrix, central direct memory access (DMA) controller, and beeper interface.

The ADuCM4050 features cryptographic hardware supporting advanced encryption standard (AES)-128 and AES-256 with secure hash algorithm (SHA)-256 and the following modes: electronic code book (ECB), cipher block chaining (CBC), counter (CTR), and cipher block chaining-message authentication code (CCM/CCM*) modes.

The ADuCM4050 has protected key storage with key wrap/unwrap, and keyed hashed message authentication code (HMAC) with key unwrap.

The ADuCM4050 supports serial port (SPORT), serial peripheral interface (SPI), I²C, and universal asynchronous receiver/transmitter (UART) peripheral interfaces.

The ADuCM4050 features a real-time clock (RTC), general-purpose and watchdog timers, and programmable general-purpose input/output (GPIO) pins. There is a hardware cyclic redundancy check (CRC) calculator with programmable generator polynomial. The device also features a power on reset (POR) and power supply monitor (PSM), a 12-bit successive approximation register (SAR) ADC, a red/green/blue (RGB) timer for driving RGB LED, and a true random number generator (TRNG).

To support low dynamic and hibernate power management, the ADuCM4050 MCU provides a collection of power modes and features such as dynamic- and software-controlled clock gating and power gating.

For full details on the ADuCM4050 MCU, refer to the [ADuCM4050 Ultra Low Power ARM Cortex-M4F MCU with Integrated Power Management Hardware Reference](#).

PRODUCT HIGHLIGHTS

1. Ultra low power consumption.
2. Robust operation.
3. Full voltage monitoring in deep sleep modes.
4. ECC support on flash.
5. Parity error detection on SRAM memory.
6. Leading edge security.
7. Fast encryption provides read protection to user algorithms.
8. Write protection prevents device reprogramming by unauthorized code.
9. Failure detection of 32 kHz low frequency external crystal oscillator (LFX TAL) via interrupt.
10. SensorStrobe™ for precise time synchronized sampling of external sensors. Works in hibernate mode, resulting in drastic current reduction in system solutions. Current consumption reduces by 10 times when using, for example, the [ADXL363](#) accelerometer. Software intervention is not required after setup. No pulse drift due to software execution.

SPECIFICATIONS

OPERATING CONDITIONS AND ELECTRICAL CHARACTERISTICS

Table 1.

Parameter	Symbol	Min	Typ	Max	Unit	Test Conditions/Comments
EXTERNAL BATTERY SUPPLY VOLTAGE ^{1,2}	V _{BAT}	1.74	3.0	3.6	V	
INPUT VOLTAGE						
High Level	V _{IH}	2.5			V	V _{BAT} = 3.6 V
Low Level	V _{IL}			0.45	V	V _{BAT} = 1.74 V
ADC SUPPLY VOLTAGE	V _{BAT_ADC}	1.74	3.0	3.6	V	
OUTPUT VOLTAGE ³						
High Level	V _{OH}	1.4			V	V _{BAT} = 1.74 V, I _{OH} = -1.0 mA
Low Level	V _{OL}			0.4	V	V _{BAT} = 1.74 V, I _{OL} = 1.0 mA
INPUT CURRENT PULL-UP ⁴						
High Level	I _{IHPU}		0.01	0.2	μA	V _{BAT} = 3.6 V, V _{IN} = 3.6 V
Low Level	I _{ILPU}			100	μA	V _{BAT} = 3.6 V, V _{IN} = 0 V
THREE-STATE LEAKAGE CURRENT						
High Level ⁵	I _{OZH}		0.01	0.15	μA	V _{BAT} = 3.6 V, V _{IN} = 3.6 V
Pull-Up ⁶	I _{OZHPU}			0.30	μA	V _{BAT} = 3.6 V, V _{IN} = 3.6 V
Pull-Down ⁷	I _{OZHPD}			100	μA	V _{BAT} = 3.6 V, V _{IN} = 3.6 V
Low Level ⁵	I _{OZL}		0.01	0.15	μA	V _{BAT} = 3.6 V, V _{IN} = 0 V
Pull-Up ⁶	I _{OZLPU}			100	μA	V _{BAT} = 3.6 V, V _{IN} = 0 V
Pull-Down ⁷	I _{OZLPD}			0.15	μA	V _{BAT} = 3.6 V, V _{IN} = 0 V
INPUT CAPACITANCE	C _{IN}		10		pF	T _J = 25°C
V _{BAT} POWER-ON RESET	V _{VBAT_POR}	1.49	1.59	1.64	V	Power-on reset level on V _{BAT} ; trip point is detected when battery is decaying ⁸
Junction Temperature	T _J	-40		+85	°C	T _{AMBIENT} = -40°C to +85°C

¹ Value applies to VBAT_ANA1, VBAT_ANA2, VBAT_DIG1, and VBAT_DIG2 pins.

² Must remain powered (even if the associated function is not used).

³ Applies to the output and bidirectional pins: P0_00 to P0_15, P1_00 to P1_15, P2_00 to P2_15, and P3_00 to P3_03.

⁴ Applies to the SYS_HWRST input pin with pull-up.

⁵ Applies to the three-state pins: P0_00 to P0_05, P0_08 to P0_15, P1_00 to P1_15, P2_00 to P2_15, P3_00 to P3_03.

⁶ Applies to the three-state pins with pull-ups: P0_00 to P0_05, P0_07 to P0_15, P1_00 to P1_15, P2_00 to P2_15, and P3_00 to P3_03.

⁷ Applies to the P0_06 three-state pin with pull-down.

⁸ This specification is valid when the device is powered up; if the battery decays and falls below 1.71 V, power-on reset is detected. For safer operation of the device, adhere to the V_{BAT} specification.

EMBEDDED FLASH SPECIFICATIONS

Table 2.

Parameter	Symbol	Min	Typ	Max	Unit	Test Conditions/Comments
FLASH						
Endurance		10,000			Cycles	
Data Retention			10		Years	

POWER SUPPLY CURRENT SPECIFICATIONS**Active Mode**

Table 3.

Parameter	Min	Typ ¹	Max ²	Unit	Test Conditions/Comments	
ACTIVE MODE ³					Current consumption when $V_{BAT} = 3.0V$	
Buck Enabled	1.27	2.71		mA	Code executing from flash, cache enabled, system peripheral clock (PCLK) disabled, advanced high performance clock (HCLK) = 26 MHz ⁴	
	1.83	3.28		mA	Code executing from flash, cache disabled, PCLK disabled, HCLK = 26 MHz ⁴	
	1.40	2.84		mA	Code executing from flash, cache enabled, PCLK = 26 MHz, HCLK = 26 MHz ⁴	
	1.97	3.41		mA	Code executing from flash, cache disabled, PCLK = 26 MHz, HCLK = 26 MHz ⁴	
	2.33	3.78		mA	Code executing from flash, cache enabled, PCLK disabled, HCLK = 52 MHz ⁵	
	2.94	4.39		mA	Code executing from flash, cache disabled, PCLK disabled, HCLK = 52 MHz ⁵	
	2.59	4.04		mA	Code executing from flash, cache enabled, PCLK = 52 MHz, HCLK = 52 MHz ⁵	
	3.21	4.65		mA	Code executing from flash, cache disabled, PCLK = 52 MHz, HCLK = 52 MHz ⁵	
	1.43	2.87		mA	Code executing from SRAM, PCLK disabled, HCLK = 26 MHz ⁴	
	1.56	3.00		mA	Code executing from SRAM, PCLK = 26 MHz, HCLK = 26 MHz ⁴	
	2.64	4.09		mA	Code executing from SRAM, PCLK disabled, HCLK = 52 MHz ⁵	
	2.90	4.35		mA	Code executing from SRAM, PCLK = 52 MHz, HCLK = 52 MHz ⁵	
	Dynamic Current Buck Disabled	41			μA/MHz	Code executing from flash, cache enabled
		2.34	4.78		mA	Code executing from flash, cache enabled, PCLK disabled, HCLK = 26 MHz ⁴
3.38		5.82		mA	Code executing from flash, cache disabled, PCLK disabled, HCLK = 26 MHz ⁴	
2.60		5.04		mA	Code executing from flash, cache enabled, PCLK = 26 MHz, HCLK = 26 MHz ⁴	
3.65		6.09		mA	Code executing from flash, cache disabled, PCLK = 26 MHz, HCLK = 26 MHz ⁴	
4.46		6.90		mA	Code executing from flash, cache enabled, PCLK disabled, HCLK = 52 MHz ⁵	
5.61		8.05		mA	Code executing from flash, cache disabled, PCLK disabled, HCLK = 52 MHz ⁵	
4.98		7.42		mA	Code executing from flash, cache enabled, PCLK = 52 MHz, HCLK = 52 MHz ⁵	
6.14		8.58		mA	Code executing from flash, cache disabled, PCLK = 52 MHz, HCLK = 52 MHz ⁵	
2.66		5.10		mA	Code executing from SRAM, PCLK disabled, HCLK = 26 MHz ⁴	
2.92		5.36		mA	Code executing from SRAM, PCLK = 26 MHz, HCLK = 26 MHz ⁴	
5.08		7.52		mA	Code executing from SRAM, PCLK disabled, HCLK = 52 MHz ⁵	
5.60		8.04		mA	Code executing from SRAM, PCLK = 52 MHz, HCLK = 52 MHz ⁵	
Dynamic Current		82			μA/MHz	Code executing from flash, cache enabled

¹ $T_J = 25^\circ C$ ² $T_J = 85^\circ C$ ³ The code being executed is a prime number generation in a continuous loop, with high frequency RC oscillator (HFOSC) as the system clock source.⁴ Zero wait states and low buck load.⁵ One wait state and high buck load.

Flexi Mode

Table 4.

Parameter	Min	Typ ¹	Max ²	Unit	Test Conditions/Comments
FLEXI™ MODE					Current consumption when $V_{BAT} = 3.0V$
Buck Enabled		0.40	1.85	mA	PCLK disabled, HCLK = 26 MHz
		0.54	1.98	mA	PCLK = 26 MHz, HCLK = 26 MHz
		0.62	2.06	mA	PCLK disabled, HCLK = 52 MHz
		0.88	2.33	mA	PCLK = 52 MHz, HCLK = 52 MHz
Buck Disabled		0.62	3.06	mA	PCLK disabled, HCLK = 26 MHz
		0.88	3.32	mA	PCLK = 26 MHz, HCLK = 26 MHz
		1.04	3.48	mA	PCLK disabled, HCLK = 52 MHz
		1.57	4.01	mA	PCLK = 52 MHz, HCLK = 52 MHz

¹ $T_J = 25^\circ C$.² $T_J = 85^\circ C$.

Deep Sleep Modes— $V_{BAT} = 1.8\text{ V}$

Table 5.

Parameter	Min	Typ	Max	Unit	Test Conditions/Comments
HIBERNATE MODE ¹					$V_{BAT} = 1.8\text{ V}$
$T_J = 25^\circ\text{C}$		0.78		μA	Real-Time Clock 1 (RTC1) and Real-Time Clock 0 (RTC0) disabled, 16 kB SRAM retained, LFX TAL off
		0.89		μA	RTC1 and RTC0 disabled, 28 kB SRAM retained, LFX TAL off
		0.96		μA	RTC1 and RTC0 disabled, 48 kB SRAM retained, LFX TAL off
		1.06		μA	RTC1 and RTC0 disabled, 60 kB SRAM retained, LFX TAL off
		1.35		μA	RTC1 and RTC0 disabled, 80 kB SRAM retained, LFX TAL off
		1.44		μA	RTC1 and RTC0 disabled, 92 kB SRAM retained, LFX TAL off
		1.51		μA	RTC1 and RTC0 disabled, 112 kB SRAM retained, LFX TAL off
		1.60		μA	RTC1 and RTC0 disabled, 124 kB SRAM retained, LFX TAL off
		0.85		μA	RTC1 enabled, 16 kB SRAM retained, low frequency RC oscillator (LFOSC) as RTC1 source
		1.66		μA	RTC1 enabled, 124 kB SRAM retained, LFOSC as RTC1 source
		1.08		μA	RTC1 enabled, 16 kB SRAM retained, LFX TAL as RTC1 source
		1.11		μA	RTC0 enabled, 16 kB SRAM retained, LFX TAL as RTC0 source
		1.14		μA	RTC1 and RTC0 enabled, 16 kB SRAM retained, LFX TAL as RTC1 and RTC0 source
		1.82		μA	RTC1 enabled, 124 kB SRAM retained, LFX TAL as RTC1 source
		1.84		μA	RTC0 enabled, 124 kB SRAM retained, LFX TAL as RTC0 source
		1.87		μA	RTC1 and RTC0 enabled, 124 kB SRAM retained, LFX TAL as RTC1 and RTC0 source
$T_J = 85^\circ\text{C}$		2.79	6.90	μA	RTC1 and RTC0 disabled, 16 kB SRAM retained, LFX TAL off
		3.46	9.00	μA	RTC1 and RTC0 disabled, 28 kB SRAM retained, LFX TAL off
		4.73	12.50	μA	RTC1 and RTC0 disabled, 48 kB SRAM retained, LFX TAL off
		5.38	14.80	μA	RTC1 and RTC0 disabled, 60 kB SRAM retained, LFX TAL off
		6.26	16.70	μA	RTC1 and RTC0 disabled, 80 kB SRAM retained, LFX TAL off
		6.85	18.70	μA	RTC1 and RTC0 disabled, 92 kB SRAM retained, LFX TAL off
		8.12	22.30	μA	RTC1 and RTC0 disabled, 112 kB SRAM retained, LFX TAL off
		8.74	24.50	μA	RTC1 and RTC0 disabled, 124 kB SRAM retained, LFX TAL off
		2.95	7.30	μA	RTC1 enabled, 16 kB SRAM retained, LFOSC as RTC1 source
		8.92	25.50	μA	RTC1 enabled, 124 kB SRAM retained, LFOSC as RTC1 source
		3.16	7.77	μA	RTC1 enabled, 16 kB SRAM retained, LFX TAL as RTC1 source
		3.16	7.78	μA	RTC0 enabled, 16 kB SRAM retained, LFX TAL as RTC0 source
		3.22	7.92	μA	RTC1 and RTC0 enabled, 16 kB SRAM retained, LFX TAL as RTC1 and RTC0 source
		9.07	25.70	μA	RTC1 enabled, 124 kB SRAM retained, LFX TAL as RTC1 source
		9.10	25.76	μA	RTC0 enabled, 124 kB SRAM retained, LFX TAL as RTC0 source
		9.15	25.91	μA	RTC1 and RTC0 enabled, 124 kB SRAM retained, LFX TAL as RTC1 and RTC0 source
SHUTDOWN MODE ¹					$V_{BAT} = 1.8\text{ V}$
$T_J = 25^\circ\text{C}$		0.03		μA	RTC0 disabled
		0.37		μA	RTC0 enabled, LFX TAL as RTC0 source
$T_J = 85^\circ\text{C}$		0.31	1.30	μA	RTC0 disabled
		0.78	2.93	μA	RTC0 enabled, LFX TAL as RTC0 source
FAST SHUTDOWN MODE ¹					$V_{BAT} = 1.8\text{ V}$
$T_J = 25^\circ\text{C}$		0.17		μA	RTC0 disabled
		0.51		μA	RTC0 enabled, LFX TAL as RTC0 source
$T_J = 85^\circ\text{C}$		0.47	1.50	μA	RTC0 disabled
		0.94	3.53	μA	RTC0 enabled, LFX TAL as RTC0 source

¹ Buck enable/disable does not affect power consumption.

Deep Sleep Modes— $V_{BAT} = 3.0\text{ V}$

Table 6.

Parameter	Min	Typ	Max	Unit	Test Conditions/Comments
HIBERNATE MODE ¹					$V_{BAT} = 3.0\text{ V}$
$T_J = 25^\circ\text{C}$		0.65		μA	RTC1 and RTC0 disabled, 16 kB SRAM retained, LFXTAL off
		0.72		μA	RTC1 and RTC0 disabled, 28 kB SRAM retained, LFXTAL off
		0.77		μA	RTC1 and RTC0 disabled, 48 kB SRAM retained, LFXTAL off
		0.83		μA	RTC1 and RTC0 disabled, 60 kB SRAM retained, LFXTAL off
		1.09		μA	RTC1 and RTC0 disabled, 80 kB SRAM retained, LFXTAL off
		1.13		μA	RTC1 and RTC0 disabled, 92 kB SRAM retained, LFXTAL off
		1.17		μA	RTC1 and RTC0 disabled, 112 kB SRAM retained, LFXTAL off
		1.22		μA	RTC1 and RTC0 disabled, 124 kB SRAM retained, LFXTAL off
		0.68		μA	RTC1 enabled, 16 kB SRAM retained, LFOSC as RTC1 source
		1.26		μA	RTC1 enabled, 124 kB SRAM retained, LFOSC as RTC1 source
		0.87		μA	RTC1 enabled, 16 kB SRAM retained, LFXTAL as RTC1 source
		0.95		μA	RTC0 enabled, 16 kB SRAM retained, LFXTAL as RTC0 source
		0.97		μA	RTC1 and RTC0 enabled, 16 kB SRAM retained, LFXTAL as RTC1 and RTC0 source
		1.38		μA	RTC1 enabled, 124 kB SRAM retained, LFXTAL as RTC1 source
		1.46		μA	RTC0 enabled, 124 kB SRAM retained, LFXTAL as RTC0 source
		1.48		μA	RTC1 and RTC0 enabled, 124 kB SRAM retained, LFXTAL as RTC1 and RTC0 source
$T_J = 85^\circ\text{C}$		2.00	4.60	μA	RTC1 and RTC0 disabled, 16 kB SRAM retained, LFXTAL off
		2.38	5.70	μA	RTC1 and RTC0 disabled, 28 kB SRAM retained, LFXTAL off
		2.98	7.80	μA	RTC1 and RTC0 disabled, 48 kB SRAM retained, LFXTAL off
		3.29	9.00	μA	RTC1 and RTC0 disabled, 60 kB SRAM retained, LFXTAL off
		4.04	10.06	μA	RTC1 and RTC0 disabled, 80 kB SRAM retained, LFXTAL off
		4.41	11.80	μA	RTC1 and RTC0 disabled, 92 kB SRAM retained, LFXTAL off
		4.94	13.70	μA	RTC1 and RTC0 disabled, 112 kB SRAM retained, LFXTAL off
		5.20	15.50	μA	RTC1 and RTC0 disabled, 124 kB SRAM retained, LFXTAL off
		2.11	5.00	μA	RTC1 enabled, 16 kB SRAM retained, LFOSC as RTC1 source
		5.32	16.00	μA	RTC1 enabled, 124 kB SRAM retained, LFOSC as RTC1 source
		2.53	5.75	μA	RTC1 enabled, 16 kB SRAM retained, LFXTAL as RTC1 source
		2.61	5.92	μA	RTC0 enabled, 16 kB SRAM retained, LFXTAL as RTC0 source
		2.64	5.98	μA	RTC1 and RTC0 enabled, 16 kB SRAM retained, LFXTAL as RTC1 and RTC0 source
		6.03	16.12	μA	RTC1 enabled, 124 kB SRAM retained, LFXTAL as RTC1 source
		6.10	16.30	μA	RTC0 enabled, 124 kB SRAM retained, LFXTAL as RTC0 source
		6.12	16.37	μA	RTC1 and RTC0 enabled, 124 kB SRAM retained, LFXTAL as RTC1 and RTC0 source
SHUTDOWN MODE ¹					$V_{BAT} = 3.0\text{ V}$
$T_J = 25^\circ\text{C}$		0.05		μA	RTC0 disabled
		0.68		μA	RTC0 enabled, LFXTAL as RTC0 source
$T_J = 85^\circ\text{C}$		0.45	1.60	μA	RTC0 disabled
		1.26	4.18	μA	RTC0 enabled, LFXTAL as RTC0 source
FAST SHUTDOWN MODE ¹					$V_{BAT} = 3.0\text{ V}$
$T_J = 25^\circ\text{C}$		0.20		μA	RTC0 disabled
		0.83		μA	RTC0 enabled, LFXTAL as RTC0 source
$T_J = 85^\circ\text{C}$		0.62	1.80	μA	RTC0 disabled
		1.43	4.74	μA	RTC0 enabled, LFXTAL as RTC0 source

¹ Buck enable/disable does not affect power consumption.

Deep Sleep Modes— $V_{BAT} = 3.6\text{ V}$

Table 7.

Parameter	Min	Typ	Max	Unit	Test Conditions/Comments
HIBERNATE MODE ¹					$V_{BAT} = 3.6\text{ V}$
$T_J = 25^\circ\text{C}$		0.66		μA	RTC1 and RTC0 disabled, 16 kB SRAM retained, LFX TAL off
		0.73		μA	RTC1 and RTC0 disabled, 28 kB SRAM retained, LFX TAL off
		0.77		μA	RTC1 and RTC0 disabled, 48 kB SRAM retained, LFX TAL off
		0.82		μA	RTC1 and RTC0 disabled, 60 kB SRAM retained, LFX TAL off
		1.04		μA	RTC1 and RTC0 disabled, 80 kB SRAM retained, LFX TAL off
		1.08		μA	RTC1 and RTC0 disabled, 92 kB SRAM retained, LFX TAL off
		1.12		μA	RTC1 and RTC0 disabled, 112 kB SRAM retained, LFX TAL off
		1.16		μA	RTC1 and RTC0 disabled, 124 kB SRAM retained, LFX TAL off
		0.69		μA	RTC1 enabled, 16 kB SRAM retained, LFOSC as RTC1 source
		1.19		μA	RTC1 enabled, 124 kB SRAM retained, LFOSC as RTC1 source
		0.85		μA	RTC1 enabled, 16 kB SRAM retained, LFX TAL as RTC1 source
		0.96		μA	RTC0 enabled, 16 kB SRAM retained, LFX TAL as RTC0 source
		0.98		μA	RTC1 and RTC0 enabled, 16 kB SRAM retained, LFX TAL as RTC1 and RTC0 source
		1.32		μA	RTC1 enabled, 124 kB SRAM retained, LFX TAL as RTC1 source
		1.43		μA	RTC0 enabled, 124 kB SRAM retained, LFX TAL as RTC0 source
		1.45		μA	RTC1 and RTC0 enabled, 124 kB SRAM retained, LFX TAL as RTC1 and RTC0 source
$T_J = 85^\circ\text{C}$		1.95	5.00	μA	RTC1 and RTC0 disabled, 16 kB SRAM retained, LFX TAL off
		2.29	6.00	μA	RTC1 and RTC0 disabled, 28 kB SRAM retained, LFX TAL off
		2.82	7.20	μA	RTC1 and RTC0 disabled, 48 kB SRAM retained, LFX TAL off
		3.14	8.20	μA	RTC1 and RTC0 disabled, 60 kB SRAM retained, LFX TAL off
		3.78	10.00	μA	RTC1 and RTC0 disabled, 80 kB SRAM retained, LFX TAL off
		4.10	11.00	μA	RTC1 and RTC0 disabled, 92 kB SRAM retained, LFX TAL off
		4.63	12.30	μA	RTC1 and RTC0 disabled, 112 kB SRAM retained, LFX TAL off
		4.95	14.90	μA	RTC1 and RTC0 disabled, 124 kB SRAM retained, LFX TAL off
		2.07	5.30	μA	RTC1 enabled, 16 kB SRAM retained, LFOSC as RTC1 source
		5.06	15.20	μA	RTC1 enabled, 124 kB SRAM retained, LFOSC as RTC1 source
		2.52	6.19	μA	RTC1 enabled, 16 kB SRAM retained, LFX TAL as RTC1 source
		2.63	6.48	μA	RTC0 enabled, 16 kB SRAM retained, LFX TAL as RTC0 source
		2.65	6.53	μA	RTC1 and RTC0 enabled, 16 kB SRAM retained, LFX TAL as RTC1 and RTC0 source
		5.51	15.34	μA	RTC1 enabled, 124 kB SRAM retained, LFX TAL as RTC1 source
		5.62	15.64	μA	RTC0 enabled, 124 kB SRAM retained, LFX TAL as RTC0 source
		5.64	15.71	μA	RTC1 and RTC0 enabled, 124 kB SRAM retained, LFX TAL as RTC1 and RTC0 source
SHUTDOWN MODE ¹					$V_{BAT} = 3.6\text{ V}$
$T_J = 25^\circ\text{C}$		0.07		μA	RTC0 disabled
		1.05		μA	RTC0 enabled, LFX TAL as RTC0 source
$T_J = 85^\circ\text{C}$		0.58	1.90	μA	RTC0 disabled
		1.79	5.57	μA	RTC0 enabled, LFX TAL as RTC0 source
FAST SHUTDOWN MODE ¹					$V_{BAT} = 3.6\text{ V}$
$T_J = 25^\circ\text{C}$		0.22		μA	RTC0 disabled
		1.21		μA	RTC0 enabled, LFX TAL as RTC0 source
$T_J = 85^\circ\text{C}$		0.75	2.10	μA	RTC0 disabled
		1.97	6.32	μA	RTC0 enabled, LFX TAL as RTC0 source

¹ Buck enable/disable does not affect power consumption.

ADC SPECIFICATIONS

Table 8.

Parameter ^{1,2}	Min	Typ ³	Max	Unit	Test Conditions/Comments
INTEGRAL NONLINEARITY ERROR					
64-Lead LFCSP		±1.6		LSB	1.8 V (V _{BAT})/1.25 V (internal/external V _{REF}) ⁴
64-Lead LFCSP		-1.7 to +1.3		LSB	3.0 V (V _{BAT})/2.5 V (internal/external V _{REF}) ⁴
72-Ball WLCSP		±1.4		LSB	1.8 V (V _{BAT})/1.25 V (internal/external V _{REF}) ⁴
DIFFERENTIAL NONLINEARITY ERROR					
64-Lead LFCSP		-0.7 to +1.15		LSB	1.8 V (V _{BAT})/1.25 V (internal/external V _{REF}) ⁴
64-Lead LFCSP		-0.7 to +1.1		LSB	3.0 V (V _{BAT})/2.5 V (internal/external V _{REF}) ⁴
72-Ball WLCSP		-0.75 to +1.0		LSB	1.8 V (V _{BAT})/1.25 V (internal/external V _{REF}) ⁴
OFFSET ERROR					
64-Lead LFCSP		±0.5		LSB	1.8 V (V _{BAT})/1.25 V (external V _{REF}) ⁴
64-Lead LFCSP		±0.5		LSB	3.0 V (V _{BAT})/2.5 V (external V _{REF}) ⁴
72-Ball WLCSP		±0.5		LSB	1.8 V (V _{BAT})/1.25 V (external V _{REF}) ⁴
GAIN ERROR					
64-Lead LFCSP		±2.5		LSB	1.8 V (V _{BAT})/1.25 V (external V _{REF}) ⁴
64-Lead LFCSP		±0.5		LSB	3.0 V (V _{BAT})/2.5 V (external V _{REF}) ⁴
72-Ball WLCSP		±3.0		LSB	1.8 V (V _{BAT})/1.25 V (external V _{REF}) ⁴
I _{V_{BAT}_ADC} ⁵					
64-Lead LFCSP		129		μA	1.8 V (V _{BAT})/1.25 V (internal V _{REF}) ⁶
64-Lead LFCSP		157		μA	3.0 V (V _{BAT})/2.5 V (internal V _{REF}) ⁶
72-Ball WLCSP		124		μA	1.8 V (V _{BAT})/1.25 V (internal V _{REF}) ⁶
64-Lead LFCSP		47		μA	1.8 V (V _{BAT})/1.25 V (external V _{REF}) ⁷
64-Lead LFCSP		51		μA	3.0 V (V _{BAT})/2.5 V (external V _{REF}) ⁷
72-Ball WLCSP		46		μA	1.8 V (V _{BAT})/1.25 V (external V _{REF}) ⁷
INTERNAL REFERENCE VOLTAGE		1.25		V	Internal reference, 1.25 V selected
		2.50		V	Internal reference, 2.5 V selected
ADC SAMPLING FREQUENCY (f _s) ⁸	0.01		1.8	MSPS	

¹ The ADC is characterized in standalone mode without core activity and minimal or no switching on the adjacent ADC channels and digital inputs/outputs.

² The specifications are characterized after performing internal ADC offset calibration.

³ T_J = 25°C.

⁴ f_{IN} = 1068 Hz, f_s = 100 kSPS, internal reference in low power mode, 400,000 samples end point method used.

⁵ Current consumption from V_{BAT}_ADC supply when ADC is performing the conversion.

⁶ f_{IN} = 1068 Hz, f_s = 100 kSPS, internal reference in low power mode.

⁷ f_{IN} = 1068 Hz, f_s = 100 kSPS, sine wave with 1.25 V p-p applied at ADC0_VIN1 channel input.

⁸ Effects of analog source impedance must be considered when selecting ADC sampling frequency.

TEMPERATURE SENSOR SPECIFICATIONS

Table 9.

Parameter	Min	Typ	Max	Unit	Test Conditions/Comments
TEMPERATURE SENSOR					Internal reference = 1.25 V with $C_{LOAD} = 0.1 \mu\text{F}$ and $4.7 \mu\text{F}$ on the VREFP_ADC pin
Accuracy		± 2		$^{\circ}\text{C}$	$T_{AMBIENT} = 25^{\circ}\text{C}$ to $+5^{\circ}\text{C}$
		± 3		$^{\circ}\text{C}$	$T_{AMBIENT} = -40^{\circ}\text{C}$ to $+85^{\circ}\text{C}$

SYSTEM CLOCKS**External Crystal Oscillator Specifications**

Table 10.

Parameter	Symbol	Min	Typ	Max	Unit	Test Conditions/Comments
LOW FREQUENCY EXTERNAL CRYSTAL OSCILLATOR (LFXTAL)						
Frequency	f_{LFXTAL}		32,768		Hz	External capacitors on SYS_LFXTAL_IN and SYS_LFXTAL_OUT pins must be selected considering the printed circuit board (PCB) trace capacitance due to routing
External Capacitance from SYS_LFXTAL_IN Pin to Ground and from SYS_LFXTAL_OUT Pin to Ground	C_{LFXTAL}	6		10	pF	
Crystal Equivalent Series Resistance	ESR_{LFXTAL}	30		50	k Ω	
Crystal Drive Level ¹				50	nW	
Oscillator Transconductance ¹	gm_{LFXTAL}	8			μ S	
HIGH FREQUENCY EXTERNAL CRYSTAL OSCILLATOR (HFXTAL)						
Frequency	f_{HFXTAL}		26		MHz	External capacitors on SYS_HFXTAL_IN and SYS_HFXTAL_OUT pins must be selected considering the PCB trace capacitance due to routing
External Capacitance from SYS_HFXTAL_IN Pin to Ground and from SYS_HFXTAL_OUT Pin to Ground	C_{HFXTAL}			20	pF	
Crystal Equivalent Series Resistance	ESR_{HFXTAL}			50	Ω	

¹ Guaranteed by design.**On-Chip Resistor-Capacitor (RC) Oscillator Specifications**

Table 11.

Parameter	Symbol	Min	Typ	Max	Unit
LOW FREQUENCY RC OSCILLATOR (LFOSC)					
Frequency	f_{LFOSC}	30,800	32,768	35,062	Hz
HIGH FREQUENCY RC OSCILLATOR (HFOSC)					
Frequency	f_{HFOSC}	25.03	26	27.07	MHz

System Clocks and Phase-Locked Loop (PLL) Specifications

Table 12.

Parameter	Symbol	Min	Typ	Max	Unit
PLL SPECIFICATIONS					
PLL Input Clock Frequency ¹	f_{PLLIN}	16		26	MHz
PLL Output Clock Frequency ^{2, 3}	f_{PLLOUT}	16		60	MHz
System Peripheral Clock (PCLK) Frequency	f_{PCLK}	0.8125		52	MHz
Advanced High Performance Bus Clock (HCLK) Frequency	f_{HCLK}	0.8125		52	MHz

¹ The input to the PLL can come from either the high frequency external crystal (HFXTAL), SYS_CLKIN pin or from the high frequency internal RC oscillator (HFOSC).² For the maximum value, the recommended settings are PLL MSEL = 13, PLL NSEL = 16, PLL DIV2 = 1 for PLL input clock = 26 MHz; and PLL MSEL = 13, PLL NSEL = 26, PLL DIV2 = 1 for PLL input clock = 16 MHz; see the [ADuCM4050 Ultra Low Power ARM Cortex-M4F MCU with Integrated Power Management Hardware Reference](#) for more information on these configuration options.³ For the minimum value, the recommended settings are PLL MSEL = 13, PLL NSEL = 30, PLL DIV2 = 0 for PLL input clock = 26 MHz; and PLL MSEL = 8, PLL NSEL = 30, PLL DIV2 = 0 for 16 MHz.

TIMING SPECIFICATIONS

Reset Timing

Table 13.

Parameter	Symbol	Min	Typ	Max	Unit
RESET TIMING REQUIREMENTS					
SYS_HWRST Asserted Pulse Width ¹	t _{WRST}	4			μs

¹ Applies after power-up sequence is complete.

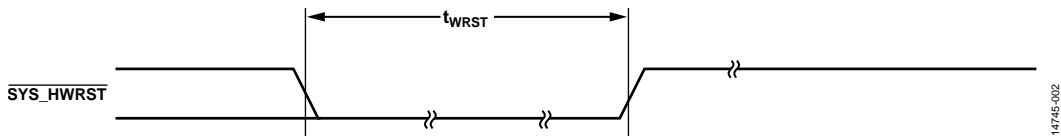

Figure 2. Reset Timing

Serial Ports Timing

Table 14.

Parameter	Symbol	Min	Typ	Max	Unit	Test Conditions/Comments
EXTERNAL CLOCK SERIAL PORTS						
Timing Requirements						
Frame Sync Setup Before-SPORT Clock ¹	t _{SFSE}	5			ns	Externally generated frame sync in transmit or receive mode
Frame Sync Hold After SPORT Clock ¹	t _{HFSE}	5			ns	Externally generated frame sync in transmit or receive mode
Receive Data Setup Before Receive SPORT Clock ¹	t _{SDRE}	5			ns	
Receive Data Hold After SPORT Clock ¹	t _{HDRE}	8			ns	
SPORT Clock Width ²	t _{SCLKW}	38.5			ns	
SPORT Clock Period ²	t _{SPTCLK}	77			ns	
Switching Characteristics ³						
Frame Sync Delay After SPORT Clock	t _{DFSE}			20	ns	Internally generated frame sync in transmit or receive mode
Frame Sync Hold After SPORT Clock	t _{HOFSE}	2			ns	Internally generated frame sync in transmit or receive mode
Transmit Data Delay After Transmit SPORT Clock	t _{DDTE}			20	ns	
Transmit Data Hold After Transmit SPORT Clock	t _{HDTE}	1			ns	
INTERNAL CLOCK SERIAL PORTS						
Timing Requirements ¹						
Receive Data Setup Before SPORT Clock	t _{SDRI}	25			ns	
Receive Data Hold After SPORT Clock	t _{HDRI}	0			ns	
Switching Characteristics						
Frame Sync Delay After SPORT Clock ³	t _{DFSI}			20	ns	Internally generated frame sync in transmit or receive mode
Frame Sync Hold After SPORT Clock ³	t _{HOFSI}	-8			ns	Internally generated frame sync in transmit or receive mode
Transmit Data Delay After SPORT Clock ³	t _{DDTI}			20	ns	
Transmit Data Hold After SPORT Clock ³	t _{HDTI}	-7			ns	
SPORT Clock Width	t _{SCLKIW}	t _{PLCK} - 1.5			ns	
SPORT Clock Period	t _{SPTCLK}	(2 × t _{PLCK}) - 1			ns	

Parameter	Symbol	Min	Typ	Max	Unit	Test Conditions/Comments
ENABLE AND THREE-STATE SERIAL PORTS						
Switching Characteristics						
Data Enable from Internal Transmit SPORT Clock ³	t_{DDTI}	5			ns	
Data Disable from Internal Transmit SPORT Clock ³	t_{DDTI}			160	ns	

¹ This specification is referenced to the sample edge.

² This specification indicates the minimum instantaneous width or period that can be tolerated due to duty cycle variation or jitter on the external SPORT Clock.

³ These specifications are referenced to the drive edge.

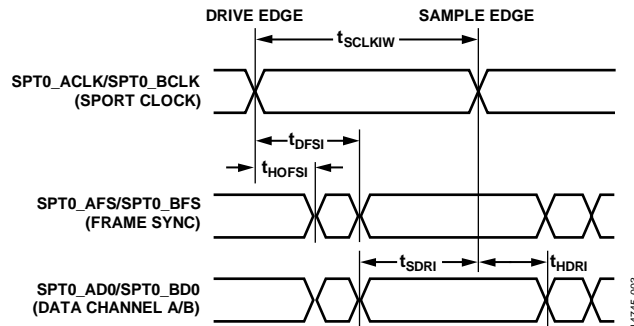

Figure 3. Serial Ports (Data Receive Mode through Internal Clock)

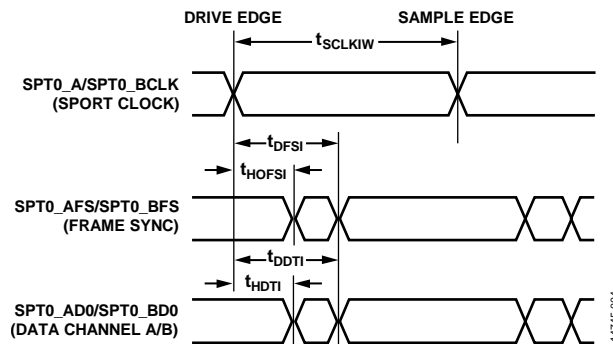

Figure 4. Serial Ports (Data Transmit Mode through Internal Clock)

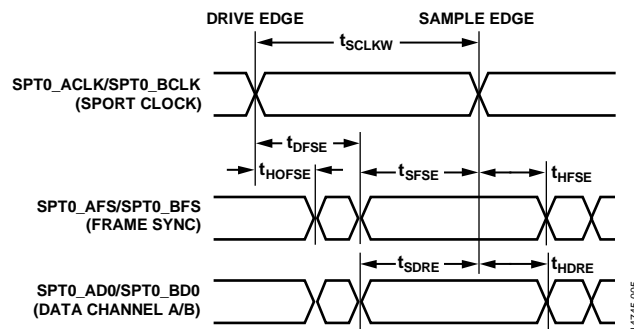

Figure 5. Serial Ports (Data Receive Mode through External Clock)

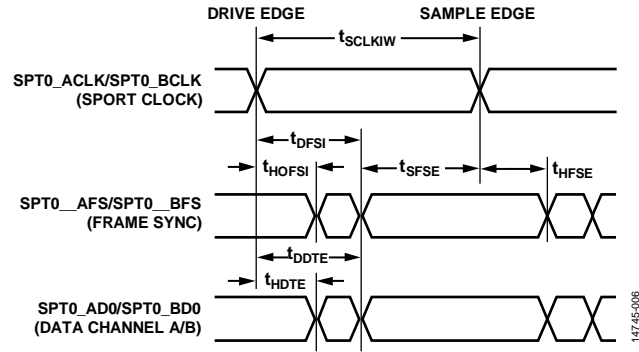

Figure 6. Serial Ports (Data Transmit Mode through External Clock)

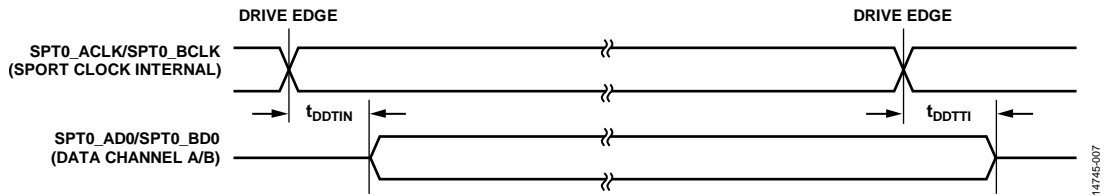

Figure 7. Enable and Three-State Serial Ports

SPI Timing**Table 15.**

Parameter ¹	Symbol	Min	Typ	Max	Unit
SPI MASTER MODE TIMING					
Timing Requirements					
Chip Select (CS) to Serial Clock (SCLK) Edge	t _{CS}	$(2 \times t_{PCLK}) - 6.5$			ns
SCLK Low Pulse Width	t _{SL}	$t_{PCLK} - 3.5$			ns
SCLK High Pulse Width	t _{SH}	$t_{PCLK} - 3.5$			ns
Data Input Setup Time Before SCLK Edge	t _{DSU}	5			ns
Data Input Hold Time After SCLK Edge	t _{DHD}	20			ns
Switching Characteristics					
Data Output Valid After SCLK Edge	t _{DAV}			25	ns
Data Output Setup Before SCLK Edge	t _{DOSU}	$t_{PCLK} - 2.2$			ns
CS High After SCLK Edge	t _{SFS}	$t_{PCLK} + 2$			ns
High Speed SPI (SPIH) MASTER MODE TIMING					
Timing Requirements					
CS to SCLK Edge	t _{CS}	$(2 \times t_{PCLK}) - 6.5$			ns
SCLK Low Pulse Width	t _{SL}	$t_{PCLK} - 2$			ns
SCLK High Pulse Width	t _{SH}	$t_{PCLK} - 2$			ns
Data Input Setup Time Before SCLK Edge	t _{DSU}	3.5			ns
Data Input Hold Time After SCLK Edge	t _{DHD}	12			ns
Switching Characteristics					
Data Output Valid After SCLK Edge	t _{DAV}			12.5	ns
Data Output Setup Before SCLK Edge	t _{DOSU}	$t_{PCLK} - 2.2$			ns
CS High After SCLK Edge	t _{SFS}	$t_{PCLK} + 2$			ns
SPI SLAVE MODE TIMING					
Timing Requirements					
CS to SCLK Edge	t _{CS}	38.5			ns
SCLK Low Pulse Width	t _{SL}	38.5			ns
SCLK High Pulse Width	t _{SH}	38.5			ns
Data Input Setup Time Before SCLK Edge	t _{DSU}	6			ns
Data Input Hold Time After SCLK Edge	t _{DHD}	8			ns
Switching Characteristics					
Data Output Valid After SCLK Edge	t _{DAV}			20	ns
Data Output Valid After CS Edge	t _{DOCS}			20	ns
CS High After SCLK Edge	t _{SFS}	38.5			ns
SPIH SLAVE MODE TIMING					
Timing Requirements					
CS to SCLK Edge	t _{CS}	19.23			ns
SCLK Low Pulse Width	t _{SL}	19.23			ns
SCLK High Pulse Width	t _{SH}	19.23			ns
Data Input Setup Time Before SCLK Edge	t _{DSU}	1			
Data Input Hold Time After SCLK Edge	t _{DHD}	1			
Switching Characteristics					
Data Output Valid After SCLK Edge	t _{DAV}			15	ns
Data Output Valid After CS Edge	t _{DOCS}			15	ns
CS High After SCLK Edge	t _{SFS}	19.23			ns

¹ These specifications are characterized with respect to double drive strength.

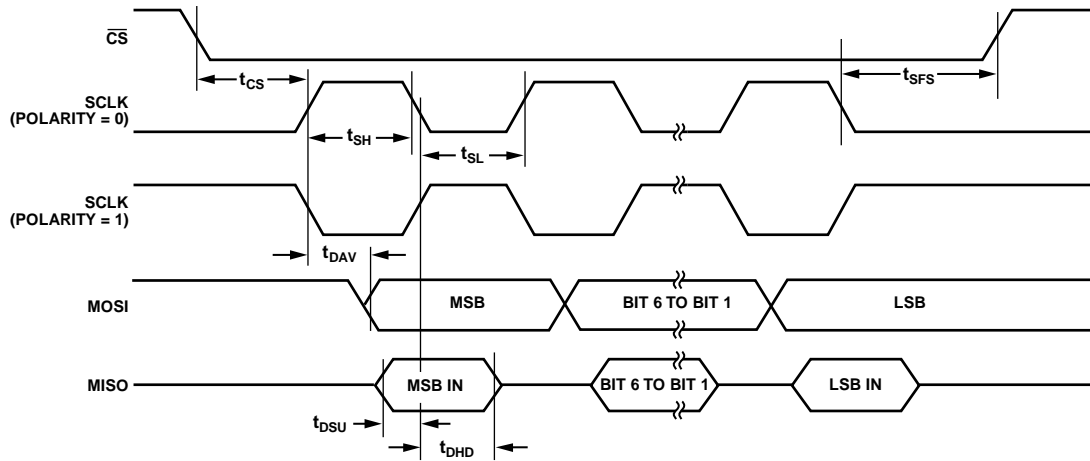

Figure 8. SPI Master Mode Timing (Phase Mode = 1)

14745-008

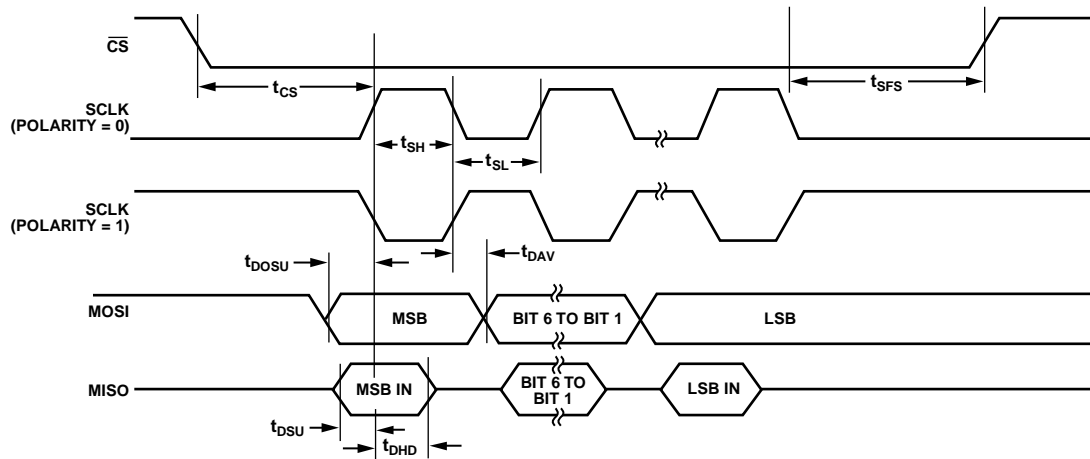

Figure 9. SPI Master Mode Timing (Phase Mode = 0)

14745-009

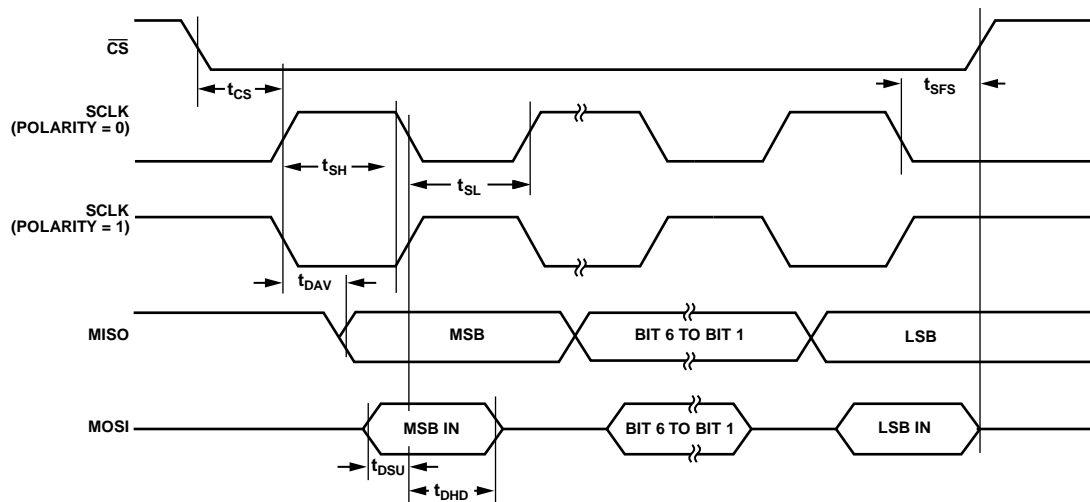

Figure 10. SPI Slave Mode Timing (Phase Mode = 1)

14745-010

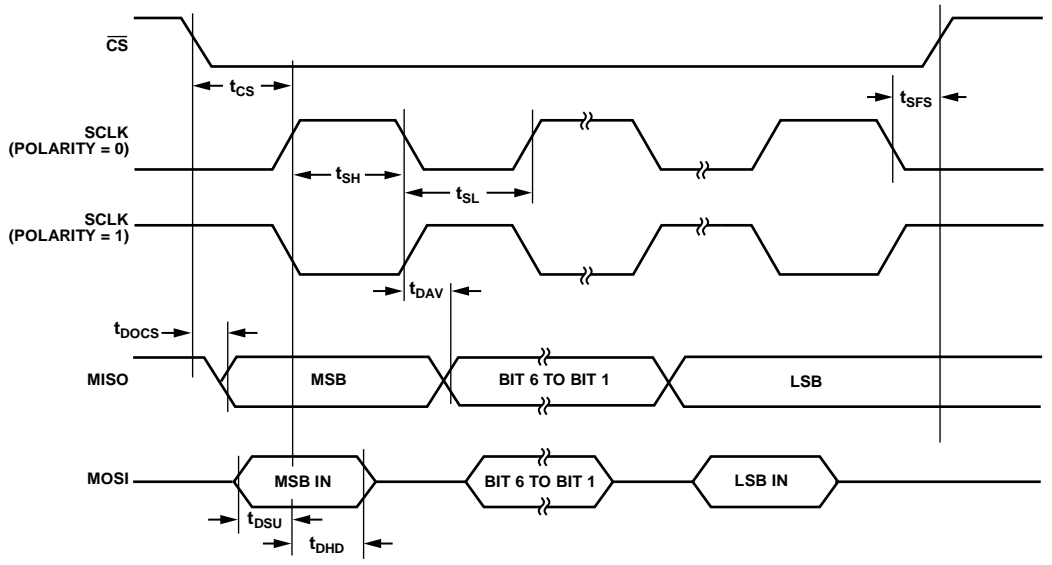

Figure 11. SPI Slave Mode Timing (Phase Mode = 0)

14745-011

I²C Specifications

Table 16.

Parameter	Symbol	Min	Typ	Max	Unit
I ² C SCLK FREQUENCY					
Standard Mode			100		kHz
Fast Mode			400		kHz

General-Purpose Port Timing

Table 17.

Parameter	Symbol	Min	Typ	Max	Unit
TIMING REQUIREMENTS					
General-Purpose Port Pin Input Pulse Width	t_{WFI}	$4 \times t_{PCLK}$			ns

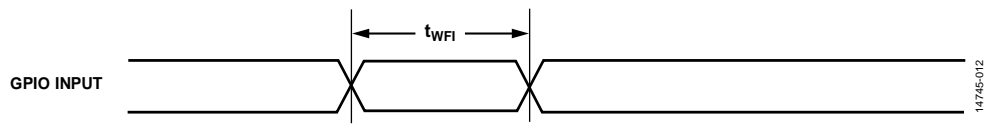

Figure 12. General-Purpose Timing

RTC1 (FLEX_RTC) Specifications

Table 18.

Parameter	Symbol	Min	Typ	Max	Unit
SensorStrobe					
Minimum Output Frequency			0.5		Hz
Maximum Output Frequency			16.384		kHz
RTC1 ALARM					
Minimum Time Resolution			30.52		μ s

Timer Pulse-Width Modulation (PWM) Output Cycle Timing

Table 19.

Parameter	Symbol	Min	Typ	Max	Unit
SWITCHING REQUIREMENTS					
Timer Pulse Width Modulation Output	t_{PWMO}	$(4 \times t_{PCLK}) - 6$		$256 \times (216 - 1)$	ns

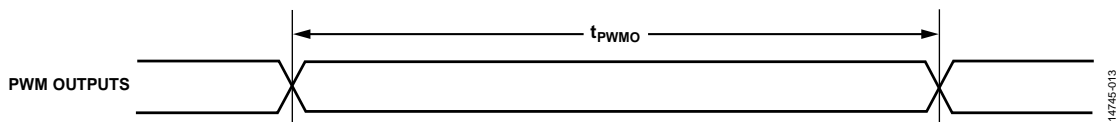

Figure 13. Timer PWM Output Cycle Timing

ABSOLUTE MAXIMUM RATINGS

Table 20.

Parameter	Rating
Supply	
VBAT_ANA1, VBAT_ANA2, VBAT_ADC, VBAT_DIG1, VBAT_DIG2, and VREFP_ADC	–0.3 V to +3.6 V
Analog	
VDCDC_CAP1N, VDCDC_CAP1P, VDCDC_OUT, VDCDC_CAP2N, and VDCDC_CAP2P	–0.3 V to +3.6 V
VLDO_OUT, SYS_HFXTAL_IN, SYS_HFXTAL_OUT, SYS_LFXTAL_IN, and SYS_LFXTAL_OUT	–0.3 V to +1.32 V
Digital Input/Output	
P0_xx, P1_xx, P2_xx, P3_xx, and SYS_HWRST	–0.3 V to +3.6 V

Stresses at or above those listed under Absolute Maximum Ratings may cause permanent damage to the product. This is a stress rating only; functional operation of the product at these or any other conditions above those indicated in the operational section of this specification is not implied. Operation beyond the maximum operating conditions for extended periods may affect product reliability.

THERMAL RESISTANCE

Thermal performance is directly linked to printed circuit board (PCB) design and operating environment. Careful attention to PCB thermal design is required. θ_{JA} can be used for a first-order approximation of T_j by the following equation:

$$T_j = T_A + (\theta_{JA} \times P_D)$$

where:

T_A is ambient temperature (°C).

T_j is junction temperature (°C).

P_D is power dissipation (to calculate power dissipation).

Table 21. Thermal Resistance

Package Type	θ_{JA}	θ_{JC}	Unit
CP-64-17	26.3	1.0	°C/W

ESD CAUTION



ESD (electrostatic discharge) sensitive device.

Charged devices and circuit boards can discharge without detection. Although this product features patented or proprietary protection circuitry, damage may occur on devices subjected to high energy ESD. Therefore, proper ESD precautions should be taken to avoid performance degradation or loss of functionality.

PIN CONFIGURATION AND FUNCTION DESCRIPTIONS

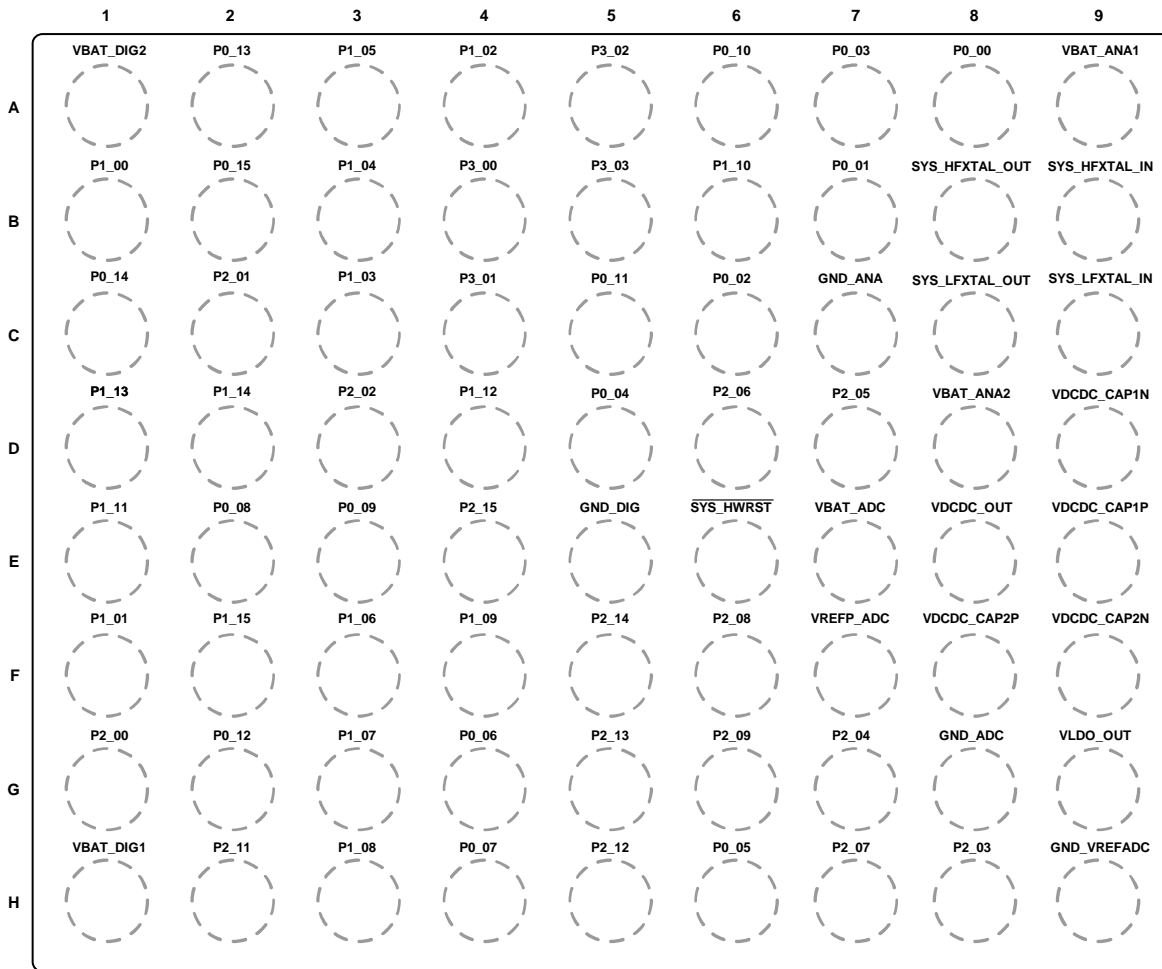

ADuCM4050
TOP VIEW
(BALL SIDE DOWN)
Not to Scale

14745-014

Figure 14. 72-Ball WLCSP Pin Configuration

Table 22. 72-Ball WLCSP Pin Function Descriptions

Pin No.	Mnemonic	Signal Names	Description
A1	VBAT_DIG2	Not applicable	External Supply for Digital Circuits in the MCU.
A2	P0_13	GPIO13/SYS_WAKE2	GPIO. See the GPIO Multiplexing section for more information.
A3	P1_05	GPIO21, SPI2_CS0	GPIO. See the GPIO Multiplexing section for more information.
A4	P1_02	GPIO18, SPI2_CLK	GPIO. See the GPIO Multiplexing section for more information.
A5	P3_02	GPIO50, RGB_TMR0_3, SPT0_ADO	GPIO. See the GPIO Multiplexing section for more information.
A6	P0_10	GPIO10, UART0_TX	GPIO. See the GPIO Multiplexing section for more information.
A7	P0_03	GPIO03, SPI0_CS0, SPT0_BCNV, SPI2_RDY	GPIO. See the GPIO Multiplexing section for more information.
A8	P0_00	GPIO00, SPI0_CLK, SPT0_BCLK	GPIO. See the GPIO Multiplexing section for more information.
A9	VBAT_ANA1	Not applicable	External Supply for Analog Circuits in the MCU.
B1	P1_00	GPIO16/SYS_WAKE1	GPIO. See the GPIO Multiplexing section for more information.
B2	P0_15	GPIO15/SYS_WAKE0	GPIO. See the GPIO Multiplexing section for more information.
B3	P1_04	GPIO20, SPI2_MISO	GPIO. See the GPIO Multiplexing section for more information.
B4	P3_00	GPIO48, RGB_TMR0_1, SPT0_ACLK	GPIO. See the GPIO Multiplexing section for more information.
B5	P3_03	GPIO51, SPT0_ACNV	GPIO. See the GPIO Multiplexing section for more information.

Pin No.	Mnemonic	Signal Names	Description
B6	P1_10	GPIO26, SPI0_CS1, SYS_CLKIN, SPI1_CS3	GPIO. See the GPIO Multiplexing section for more information.
B7	P0_01	GPIO01, SPI0_MOSI, SPT0_BFS	GPIO. See the GPIO Multiplexing section for more information.
B8	SYS_HFXTAL_OUT	Not applicable	High Frequency Crystal Output.
B9	SYS_HFXTAL_IN	Not applicable	High Frequency Crystal Input.
C1	P0_14	GPIO14, TMR0_OUT, SPI1_RDY	GPIO. See the GPIO Multiplexing section for more information.
C2	P2_01	GPIO33/SYS_WAKE3, TMR2_OUT	GPIO. See the GPIO Multiplexing section for more information.
C3	P1_03	GPIO19, SPI2_MOSI	GPIO. See the GPIO Multiplexing section for more information.
C4	P3_01	GPIO49, RGB_TMR0_2, SPT0_AFS	GPIO. See the GPIO Multiplexing section for more information.
C5	P0_11	GPIO11, UART0_RX	GPIO. See the GPIO Multiplexing section for more information.
C6	P0_02	GPIO02, SPI0_MISO, SPT0_BD0	GPIO. See the GPIO Multiplexing section for more information.
C7	GND_ANA	Not applicable	Ground Reference for Analog Circuits in the MCU.
C8	SYS_LFXTAL_OUT	Not applicable	Low Frequency Crystal Output.
C9	SYS_LFXTAL_IN	Not applicable	Low Frequency Crystal Input.
D1	P1_13	GPIO29, TMR2_OUT	GPIO. See the GPIO Multiplexing section for more information.
D2	P1_14	GPIO30, SPI0_RDY	GPIO. See the GPIO Multiplexing section for more information.
D3	P2_02	GPIO34, SPT0_ACNV, SPI1_CS2	GPIO. See the GPIO Multiplexing section for more information.
D4	P1_12	GPIO28, RTC1_SS2	GPIO. See the GPIO Multiplexing section for more information.
D5	P0_04	GPIO04, I2C0_SCL	GPIO. See the GPIO Multiplexing section for more information.
D6	P2_06	GPIO38, ADC0_VIN3	GPIO. See the GPIO Multiplexing section for more information.
D7	P2_05	GPIO37, ADC0_VIN2	GPIO. See the GPIO Multiplexing section for more information.
D8	VBAT_ANA2	Not applicable	External Supply for Analog Circuits in the MCU.
D9	VDCDC_CAP1N	Not applicable	Buck Converter Capacitor 1 Negative Terminal.
E1	P1_11	GPIO27, TMR1_OUT	GPIO. See the GPIO Multiplexing section for more information.
E2	P0_08	GPIO08, BPR0_TONE_N	GPIO. See the GPIO Multiplexing section for more information.
E3	P0_09	GPIO09, BPR0_TONE_P, SPI2_CS1	GPIO. See the GPIO Multiplexing section for more information.
E4	P2_15	GPIO47, SPI2_CS2, SPI1_CS3, SPI0_CS1	GPIO. See the GPIO Multiplexing section for more information.
E5	GND_DIG	Not applicable	Ground Reference for Digital Circuits in the MCU.
E6	SYS_HWRST	Not applicable	Hardware Reset Pin.
E7	VBAT_ADC	Not applicable	External Supply for Internal ADC.
E8	VDCDC_OUT	Not applicable	Buck Converter Output. This pin is only for connecting the decoupling capacitor. Do not connect to external load.
E9	VDCDC_CAP1P	Not applicable	Buck Converter Capacitor 1 Positive Terminal.
F1	P1_01	SYS_BMODE0, GPIO17	GPIO. See the GPIO Multiplexing section for more information.
F2	P1_15	GPIO31, SPT0_ACLK, UART1_TX	GPIO. See the GPIO Multiplexing section for more information.
F3	P1_06	GPIO22, SPI1_CLK, RGB_TMR0_1	GPIO. See the GPIO Multiplexing section for more information.
F4	P1_09	GPIO25, SPI1_CS0, SWV	GPIO. See the GPIO Multiplexing section for more information.
F5	P2_14	GPIO46, SPI0_CS3	GPIO. See the GPIO Multiplexing section for more information.
F6	P2_08	GPIO40, ADC0_VIN5, SPI0_CS2, RTC1_SS3	GPIO. See the GPIO Multiplexing section for more information.
F7	VREFP_ADC	Not applicable	External Reference Voltage for Internal ADC.
F8	VDCDC_CAP2P	Not applicable	Buck Converter Capacitor 2 Positive Terminal.
F9	VDCDC_CAP2N	Not applicable	Buck Converter Capacitor 2 Negative Terminal.
G1	P2_00	GPIO32, SPT0_AFS, UART1_RX	GPIO. See the GPIO Multiplexing section for more information.
G2	P0_12	GPIO12, SPT0_AD0, UART0_SOUT_EN	GPIO. See the GPIO Multiplexing section for more information.
G3	P1_07	GPIO23, SPI1_MOSI, RGB_TMR0_2	GPIO. See the GPIO Multiplexing section for more information.
G4	P0_06	SWD0_CLK, GPIO06	GPIO. See the GPIO Multiplexing section for more information.
G5	P2_13	GPIO45, UART1_RX, SPI0_CS2	GPIO. See the GPIO Multiplexing section for more information.
G6	P2_09	GPIO41, ADC0_VIN6, SPI0_CS3	GPIO. See the GPIO Multiplexing section for more information.

Pin No.	Mnemonic	Signal Names	Description
G7	P2_04	GPIO36, ADC0_VIN1	GPIO. See the GPIO Multiplexing section for more information.
G8	GND_ADC	Not applicable	Ground Pin for Internal ADC.
G9	VLDO_OUT	Not applicable	Low Drop Out Regulator Output. This pin is only for connecting the decoupling capacitor. Do not connect to external load.
H1	VBAT_DIG1	Not applicable	External Supply for Digital Circuits in the MCU.
H2	P2_11	GPIO43, SPI1_CS1, SYS_CLKOUT, RTC1_SS1	GPIO. See the GPIO Multiplexing section for more information.
H3	P1_08	GPIO24, SPI1_MISO, RGB_TMR0_3	GPIO. See the GPIO Multiplexing section for more information.
H4	P0_07	SWD0_DATA, GPIO07	GPIO. See the GPIO Multiplexing section for more information.
H5	P2_12	GPIO44, UART1_TX, SPI2_CS3	GPIO. See the GPIO Multiplexing section for more information.
H6	P0_05	GPIO05, I2C0_SDA	GPIO. See the GPIO Multiplexing section for more information.
H7	P2_07	GPIO39, ADC0_VIN4, SPI2_CS3	GPIO. See the GPIO Multiplexing section for more information.
H8	P2_03	GPIO35, ADC0_VIN0	GPIO. See the GPIO Multiplexing section for more information.
H9	GND_VREFADC	Not applicable	Ground for ADC Reference Supply.

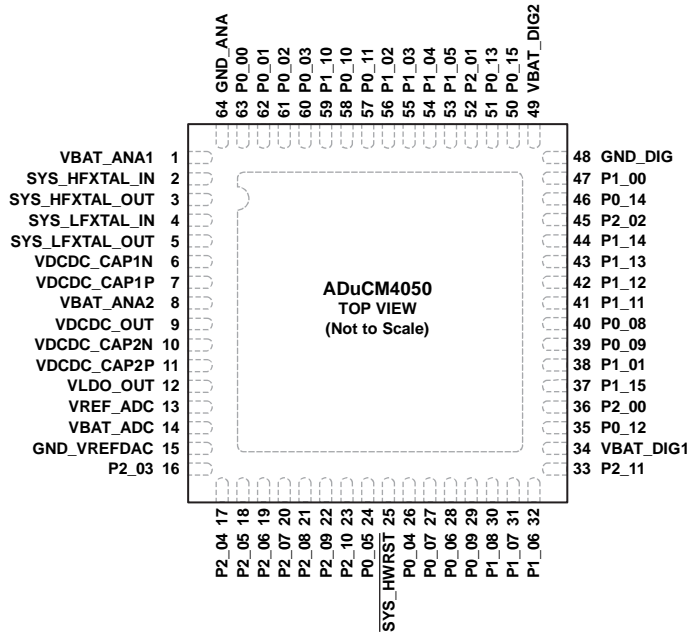

NOTES
 1. EXPOSED PAD. THE EXPOSED PAD MUST BE GROUNDED.

14746-015

Figure 15. 64-Lead LFCSP Pin Configuration

Table 23. 64-Lead LFCSP Pin Function Descriptions

Pin No.	Mnemonic	Signal Names	Description
1	VBAT_ANA1	Not applicable	External Supply for Analog Circuits in the MCU.
2	SYS_HFXTAL_IN	Not applicable	High Frequency Crystal Input.
3	SYS_HFXTAL_OUT	Not applicable	High Frequency Crystal Output.
4	SYS_LFXTAL_IN	Not applicable	Low Frequency Crystal Input.
5	SYS_LFXTAL_OUT	Not applicable	Low Frequency Crystal Output.
6	VDCDC_CAP1N	Not applicable	Buck Converter Capacitor 1 Negative Terminal.
7	VDCDC_CAP1P	Not applicable	Buck Converter Capacitor 1 Positive Terminal.
8	VBAT_ANA2	Not applicable	External Supply for Analog Circuits in the MCU.
9	VDCDC_OUT	Not applicable	Buck Converter Output. This pin is only for connecting the decoupling capacitor. Do not connect to external load.
10	VDCDC_CAP2N	Not applicable	Buck Converter Capacitor 2 Negative Terminal.
11	VDCDC_CAP2P	Not applicable	Buck Converter Capacitor 2 Positive Terminal.
12	VLDO_OUT	Not applicable	Low Dropout Regulator Output. This pin is only for connecting the decoupling capacitor. Do not connect to external load.
13	VREF_ADC	Not applicable	External Reference Voltage for Internal ADC.
14	VBAT_ADC	Not applicable	External Supply for Internal ADC.
15	GND_VREFDAC	Not applicable	Ground for Internal ADC.
16	P2_03	GPIO35, ADC0_VIN0	GPIO. See the GPIO Multiplexing section for more information.
17	P2_04	GPIO36, ADC0_VIN1	GPIO. See the GPIO Multiplexing section for more information.
18	P2_05	GPIO37, ADC0_VIN2	GPIO. See the GPIO Multiplexing section for more information.
19	P2_06	GPIO38, ADC0_VIN3	GPIO. See the GPIO Multiplexing section for more information.
20	P2_07	GPIO39, ADC0_VIN4, SPI2_CS3	GPIO. See the GPIO Multiplexing section for more information.
21	P2_08	GPIO40, ADC0_VIN5, SPI0_CS2, RTC1_SS3	GPIO. See the GPIO Multiplexing section for more information.
22	P2_09	GPIO41, ADC0_VIN6, SPI0_CS3	GPIO. See the GPIO Multiplexing section for more information.
23	P2_10	GPIO42, ADC0_VIN7, SPI2_CS2	GPIO.
24	P0_05	GPIO05, I2C0_SDA	GPIO. See the GPIO Multiplexing section for more information.
25	SYS_HWRST	Not applicable	Hardware Reset Pin.
26	P0_04	GPIO04, I2C0_SCL	GPIO. See the GPIO Multiplexing section for more information.
27	P0_07	SWD0_DATA, GPIO07	GPIO. See the GPIO Multiplexing section for more information.

Pin No.	Mnemonic	Signal Names	Description
28	P0_06	SWD0_CLK, GPIO06	GPIO. See the GPIO Multiplexing section for more information.
29	P1_09	GPIO25, SPI1_CS0, SWV	GPIO. See the GPIO Multiplexing section for more information.
30	P1_08	GPIO24, SPI1_MISO, RGB_TMR0_3	GPIO. See the GPIO Multiplexing section for more information.
31	P1_07	GPIO23, SPI1_MOSI, RGB_TMR0_2	GPIO. See the GPIO Multiplexing section for more information.
32	P1_06	GPIO22, SPI1_CLK, RGB_TMR0_1	GPIO. See the GPIO Multiplexing section for more information.
33	P2_11	GPIO43, SPI1_CS1, SYS_CLKOUT, RTC1_SS1	GPIO. See the GPIO Multiplexing section for more information.
34	VBAT_DIG1	Not applicable	External Supply for Digital Circuits in the MCU.
35	P0_12	GPIO12, SPT0_AD0, UART0_SOUT_EN	GPIO. See the GPIO Multiplexing section for more information.
36	P2_00	GPIO32, SPT0_AFS, UART1_RX	GPIO. See the GPIO Multiplexing section for more information.
37	P1_15	GPIO31, SPT0_ACLK, UART1_TX	GPIO. See the GPIO Multiplexing section for more information.
38	P1_01	SYS_BMODE0, GPIO17	GPIO. See the GPIO Multiplexing section for more information.
39	P0_09	GPIO09, BPRO_TONE_P, SPI2_CS1	GPIO. See the GPIO Multiplexing section for more information.
40	P0_08	GPIO08, BPRO_TONE_N	GPIO. See the GPIO Multiplexing section for more information.
41	P1_11	GPIO27, TMR1_OUT	GPIO. See the GPIO Multiplexing section for more information.
42	P1_12	GPIO28, RTC1_SS2	GPIO. See the GPIO Multiplexing section for more information.
43	P1_13	GPIO29, TMR2_OUT	GPIO. See the GPIO Multiplexing section for more information.
44	P1_14	GPIO30, SPI0_RDY	GPIO. See the GPIO Multiplexing section for more information.
45	P2_02	GPIO34, SPT0_ACNV, SPI1_CS2	GPIO. See the GPIO Multiplexing section for more information.
46	P0_14	GPIO14, TMR0_OUT, SPI1_RDY	GPIO. See the GPIO Multiplexing section for more information.
47	P1_00	GPIO16/SYS_WAKE1	GPIO. See the GPIO Multiplexing section for more information.
48	GND_DIG	Not applicable	Ground Reference for Digital Circuits in the MCU.
49	VBAT_DIG2	Not applicable	External Supply for Digital Circuits in the MCU.
50	P0_15	GPIO15/SYS_WAKE0	GPIO. See the GPIO Multiplexing section for more information.
51	P0_13	GPIO13/SYS_WAKE2	GPIO. See the GPIO Multiplexing section for more information.
52	P2_01	GPIO33/SYS_WAKE3, TMR2_OUT	GPIO. See the GPIO Multiplexing section for more information.
53	P1_05	GPIO21, SPI2_CS0	GPIO. See the GPIO Multiplexing section for more information.
54	P1_04	GPIO20, SPI2_MISO	GPIO. See the GPIO Multiplexing section for more information.
55	P1_03	GPIO19, SPI2_MOSI	GPIO. See the GPIO Multiplexing section for more information.
56	P1_02	GPIO18, SPI2_CLK	GPIO. See the GPIO Multiplexing section for more information.
57	P0_11	GPIO11, UART0_RX	GPIO. See the GPIO Multiplexing section for more information.
58	P0_10	GPIO10, UART0_TX	GPIO. See the GPIO Multiplexing section for more information.
59	P1_10	GPIO26, SPI0_CS1, SYS_CLKIN, SPI1_CS3	GPIO. See the GPIO Multiplexing section for more information.
60	P0_03	GPIO03, SPI0_CS0, SPT0_BCNV, SPI2_RDY	GPIO. See the GPIO Multiplexing section for more information.
61	P0_02	GPIO02, SPI0_MISO, SPT0_BD0	GPIO. See the GPIO Multiplexing section for more information.
62	P0_01	GPIO01, SPI0_MOSI, SPT0_BFS	GPIO. See the GPIO Multiplexing section for more information.
63	P0_00	GPIO00, SPI0_CLK, SPT0_BCLK	GPIO. See the GPIO Multiplexing section for more information.
64	GND_ANA	Not applicable	Ground Reference for Analog Circuits in the MCU.
	EPAD	Not applicable	Exposed Pad. The exposed pad must be grounded.

TYPICAL PERFORMANCE CHARACTERISTICS

Figure 16 through Figure 21 show the typical current voltage characteristics for the output drivers of the MCU. The curves represent the current drive capability of the output drivers as a function of output voltage.

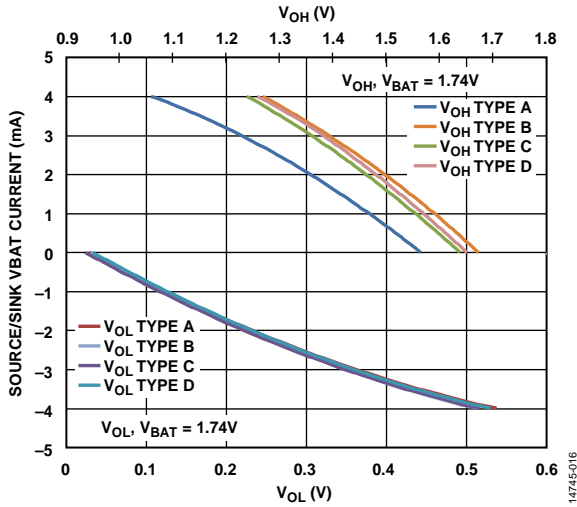

Figure 16. Output Double Drive Strength Characteristics ($V_{BAT} = 1.74 V$)

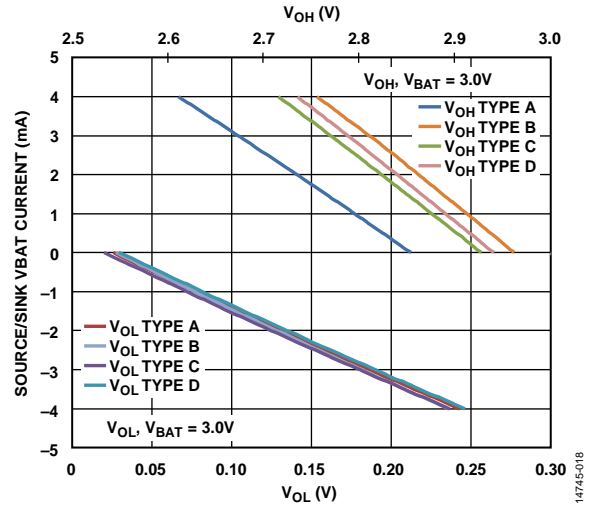

Figure 18. Output Double Drive Strength Characteristics ($V_{BAT} = 3.0 V$)

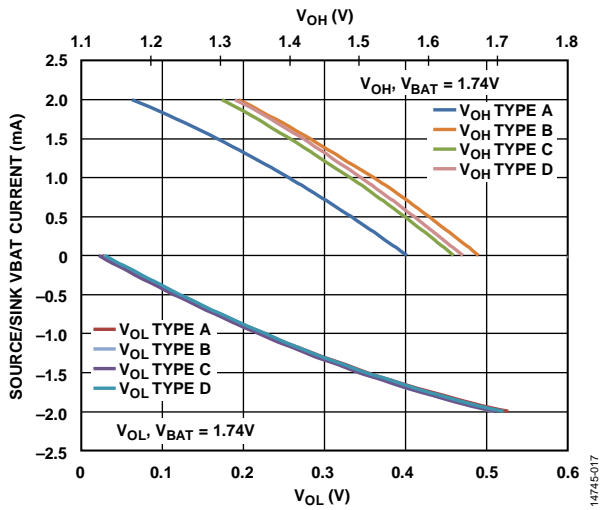

Figure 17. Output Single Drive Strength Characteristics ($V_{BAT} = 1.74 V$)

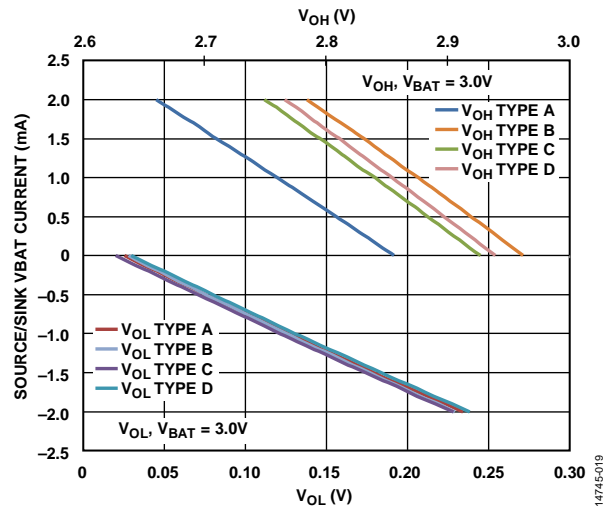

Figure 19. Output Single Drive Strength Characteristics ($V_{BAT} = 3.0 V$)

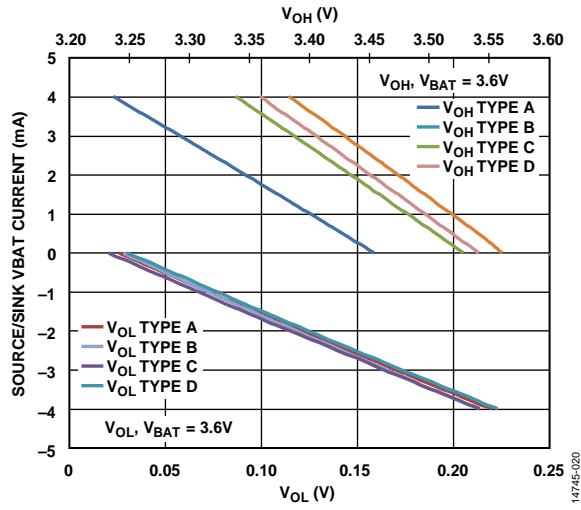

Figure 20. Output Double Drive Strength Characteristics ($V_{BAT} = 3.6\text{ V}$)

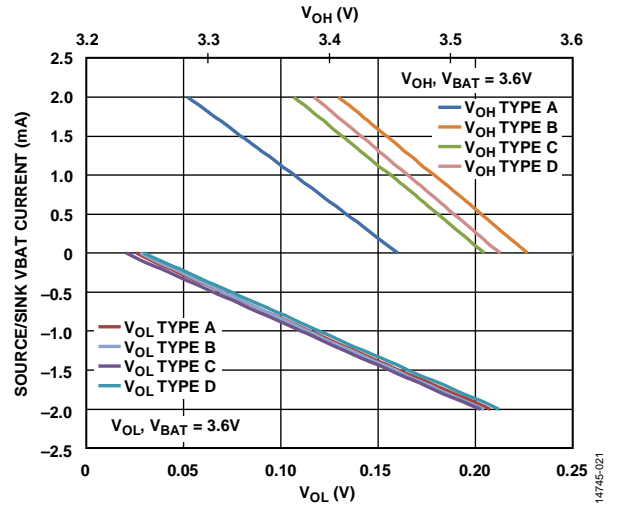

Figure 21. Output Single Drive Strength Characteristics ($V_{BAT} = 3.6\text{ V}$)

THEORY OF OPERATION

ARM CORTEX-M4F PROCESSOR

The ARM Cortex-M4F core is a 32-bit reduced instruction set computer (RISC). The length of the data can be 8 bits, 16 bits, or 32 bits. The length of the instruction word is 16 bits or 32 bits. The processor has the following features:

- ARM Cortex-M4F architecture
- Thumb-2 instruction set architecture (ISA) technology
- Three-stage pipeline with branch speculation
- Low latency interrupt processing with tail chaining
- Single-cycle multiply
- Hardware divide instructions
- Nested vectored interrupt controller (NVIC) (72 interrupts and 8 priorities)
- Six hardware breakpoints and one watchpoint (unlimited software breakpoints using the Segger JLink debug probe)
- Bit banding support
- Trace support—instruction trace macrocell (ITM), trace port interface unit (TPIU), and data watchpoint and trace (DWT) triggers and counters
- Memory protection unit (MPU)
- Eight-region MPU with subregions and background region
- Programmable clock generator unit
- Configurable for ultralow power operation
- Deep sleep modes, dynamic power management
- Programmable clock generator unit
- Floating point unit (FPU)
- Supports single-precision add, subtract, multiply, divide, multiply and accumulate, and square root operations
- Provides conversions between fixed point and floating point data formats, and floating point constant instructions

ARM Cortex-M4F Subsystem

The ADuCM4050 MCU memory map (see the [ADuCM4050 Ultra Low Power ARM Cortex-M4F MCU with Integrated Power Management Hardware Reference](#)) is based on the ARM Cortex-M4F memory model. By retaining the standardized memory mapping, it is easier to port applications across ARM Cortex-M4F platforms. The ADuCM4050 application development is based on memory blocks across code and SRAM regions. Sufficient internal memory is available via internal SRAM and internal flash.

Code Region

Accesses in the code region (0x0000_0000 to 0x0007_FFFF except 0x0007_F000 to 0x0007_FFFF, which is meant for protected key storage) are performed by the core and target the memory and cache resources.

SRAM Region

Accesses in the SRAM region (see Figure 22) are performed by the ARM Cortex-M4F core. The SRAM region of the core can act as a data region for an application.

- Internal SRAM data region. This space can contain read/write data. Internal SRAM can be partitioned between code and data (the SRAM region in the ARM Cortex-M4F space) in 32 kB blocks. Access to this region occurs at core clock speed with no wait states. The SRAM data region also supports read/write access by the ARM Cortex-M4F core and read/write DMA access by system devices.
- System memory mapped registers (MMRs). Various system MMRs reside in this region.

System Region

Accesses in this region (0xE000_0000 to 0xFFFF_FFFF) are performed by the ARM Cortex-M4F core and handled within the ARM Cortex-M4F platform. This system region includes the following components:

- CoreSight™ read only memory (ROM). The ROM table entries (see the ARM Cortex-M4F Technical Reference Manual) show the debug components of the processor.
- ARM advanced peripheral bus (APB) peripheral. This space is defined by ARM and occupies the bottom 256 kB of the system region (0xE000_0000 to 0xE004_0000). The space supports read/write access by the ARM Cortex-M4F core to the internal peripherals of the ARM core (NVIC, system control space (SCS), and wake-up interrupt controller (WIC)) and CoreSight ROM. It is not accessible by system DMA.
- Platform control register. This space has registers within the ARM Cortex-M4F platform component that control the ARM core, its memory, and the code cache. It is accessible by the ARM Cortex-M4F core (but not accessible by system DMA).

MEMORY ARCHITECTURE

The internal memory of the ADuCM4050 MCU is shown in Figure 22. It incorporates 512 kB of embedded flash memory for program code and nonvolatile data storage, 96 kB of data SRAM, and 32 kB of SRAM (configured as instruction space or data space).

SRAM Region

This memory space contains the application instructions and variables data, which must be accessed in real time. It supports read/write access by the ARM Cortex-M4F core and read/write DMA access by system peripherals. Byte, half-word and word accesses are supported.

SRAM is divided into 96 kB data SRAM and 32 kB instruction SRAM. If instruction SRAM is not enabled, then the associated 32 kB can be mapped as data SRAM, resulting in 128 kB of data SRAM.

When the cache controller is enabled, 4 kB of the instruction SRAM is reserved as cache memory. Optional parity bit error detection is available on all SRAM memories. Multiple parity bits are associated with each 32-bit word.

In hibernate mode, up to 124 kB of SRAM can be retained in the following ways:

- 124 kB of data SRAM
- 96 kB of data SRAM and 28 kB of instruction SRAM

MMRs (Peripheral Control and Status)

For the address space containing MMRs, refer to Figure 22. These registers provide control and status for on-chip peripherals of the ADuCM4050 MCU.

For more information about the MMRs, refer to the [ADuCM4050 Ultra Low Power ARM Cortex-M4F MCU with Integrated Power Management Hardware Reference](#).

Flash Memory

The ADuCM4050 MCU includes 512 kB of embedded flash memory, which is accessed using a flash controller. The flash controller is coupled with a cache controller. A prefetch mechanism is implemented in the flash controller to optimize code performance.

Flash writes are supported by a keyhole mechanism via APB writes to MMRs. The flash controller provides support for DMA-based keyhole writes.

The device supports the following with consideration to flash integrity:

- A fixed user key required for running protected commands, including mass erase and page erase.
- An optional and user definable user failure analysis key (FAA key).
- An optional and user definable write protection for user-accessible memory.
- 8-bit ECC.

Cache Controller

The ADuCM4050 MCU has an optional 4 kB instruction cache. In certain applications, enabling the cache and executing the code can result in lower power consumption rather than operating directly from flash. When enabling the cache controller, 4 kB of instruction SRAM is reserved as cache memory. In hibernate mode, the cache memory is not retained.

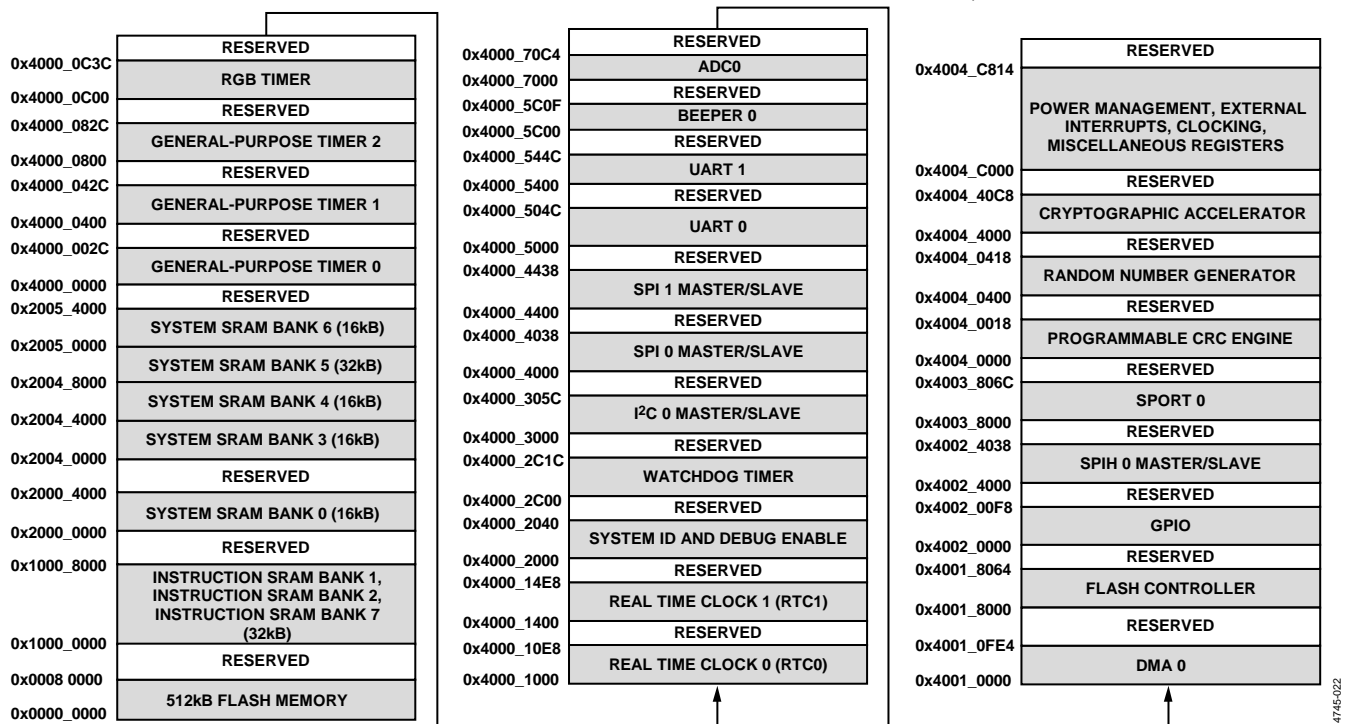

Figure 22. ADuCM4050 Memory Map—SRAM Mode 0

SYSTEM INTEGRATION FEATURES

The ADuCM4050 MCU provides several features for development of ultra low power, secure, and robust systems.

Reset

There are four kinds of resets: external, power-on, watchdog timeout, and software system reset. The software system reset is provided as part of the ARM Cortex-M4F core. The `SYS_HWRST` pin is toggled to perform a hardware reset.

Booting

The ADuCM4050 MCU supports two boot modes: booting from internal flash and upgrading software through UART download (see Table 24). If `SYS_BMODE0` (Pin P1_01) is pulled low during power-up or a hard reset, the MCU enters into serial download mode. In this mode, an on-chip loader routine initiates in the kernel, which configures the UART port and communicates with the host to manage the firmware upgrade via a specific serial download protocol.

Table 24. Boot Modes

Boot Mode	Description
0	UART download mode.
1	Flash boot. Boot from integrated flash memory.

Power Management and Modes

The ADuCM4050 MCU has an integrated power management system that optimizes performance and extends the battery life of the device. The power management system consists of the following:

- Integrated 1.2 V low dropout regulator (LDO) and optional capacitive buck regulator
- Integrated power switches for low standby current in hibernate and shutdown modes

Additional power management features include the following:

- Customized clock gating for active modes
- Power gating to reduce leakage in hibernate and shutdown modes
- Flexible sleep modes
- Shutdown mode with no retention
- Optional high efficiency buck converter to reduce power
- Integrated low power oscillators

The PMU provides control of the ADuCM4050 MCU power modes and allows the ARM Cortex-M4F to control the clocks and power gating to reduce the power consumption. Several power modes are available, offering options to balance power consumption and functionality. The power modes available in the ADuCM4050 are described in the following sections.

Active Mode

In active mode, all peripherals can be enabled. Active power is managed by optimized clock management. See Table 3 for details on active mode current consumption.

Flexi Mode

In flexi mode, the ARM Cortex-M4F core is clock gated, but the remainder of the system is active. No instructions can be executed in this mode, but DMA transfers can continue between peripherals as well as memory to memory. See Table 4 for details on flexi mode current consumption.

Hibernate Mode

Hibernate mode provides state retention, configurable SRAM and port pin retention, a limited number of wake-up interrupts (`SYS_WAKEx`, `UART0_RX`, and optionally, `RTC0` and `RTC1` (`FLEX_RTC™`)).

Shutdown Mode

Shutdown mode is the deepest sleep mode, in which all the digital and analog circuits are powered down with an option to wake from four possible wake-up sources. The `RTC0` can be (optionally) enabled in this mode, and the device can be periodically woken up by the `RTC0` interrupt.

Shutdown Mode—Fast Wake-Up

This mode has a faster wake-up time than shutdown mode at the expense of higher power consumption. See Table 25 for wake-up time specifications.

Power Management and Control

The following features are available for power management and control:

- Voltage range of 1.74 V to 3.6 V using a single supply (such as the CR2032 coin cell battery).
- GPIOs are driven directly from the battery. The pin state is retained in hibernate and shutdown modes. The GPIO configuration is only retained in hibernate mode.
- Wake-up from external interrupts (via GPIOs), `UART0_RX` interrupt, and RTCs for hibernate mode.
- Wake-up from external interrupts (via GPIOs) and `RTC0` for shutdown mode.
- Optional high power buck converter for 1.2 V full on support (MCU use only). See Figure 23 for suggested external circuitry.

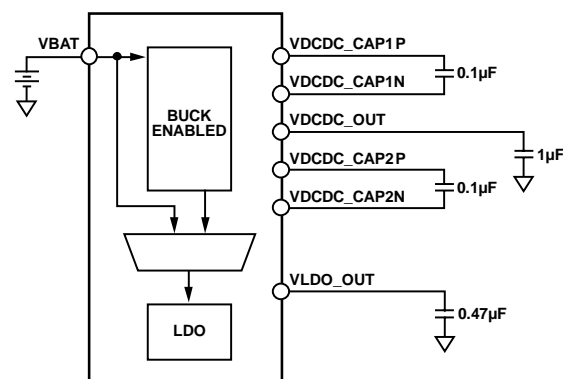

NOTES

1. FOR DESIGNS IN WHICH THE OPTIONAL BUCK IS NOT USED, THE FOLLOWING PINS MUST BE LEFT UNCONNECTED: `VDCDC_CAP1P`, `VDCDC_CAP1N`, `VDCDC_OUT`, `VDCDC_CAP2P`, AND `VDCDC_CAP2N`.

14745-023

Figure 23. Buck Enable Design

Table 25. Power Modes Wake-Up Times

Mode	VTOR ¹	Root Clock	HCLK/PCLK	Wake-Up Time
Flexi	Flash	HFOSC	26 MHz	1.605 μ s
Hibernate	Flash	HFOSC	26 MHz	10.356 μ s
	SRAM	HFOSC	26 MHz	4.984 μ s
	Flash	HFXTAL	26 MHz	686.452 μ s
	Flash	PLL_HFOSC	26 MHz	14.487 μ s
	Flash	PLL_HFXTAL	26 MHz	742.668 μ s
	Flash	PLL_HFOSC	52 MHz	15.730 μ s
	Flash	PLL_HFXTAL	52 MHz	726.101 μ s
	Flash	HFOSC	26 MHz	68.144 ms
Shutdown	Flash	HFOSC	26 MHz	1.220 ms
Shutdown (Fast Wake-Up)	Flash	HFOSC	26 MHz	

¹ VTOR means vector table offset register.

Security Features

The ADuCM4050 MCU provides a combination of hardware and software protection mechanisms that lock out access to the device in secure mode, but grant access in open mode. These mechanisms include the password protected slave boot mode (UART), as well as password protected serial wire debug (SWD) interfaces. Mechanisms are provided to protect the device contents (flash, SRAM, CPU registers, and peripheral registers) from being read through an external interface by an unauthorized user. This is referred to as read protection.

It is possible to protect the device from being reprogrammed in circuit with unauthorized code. This is referred to as in circuit write protection.

The device can be configured with no protection, read protection, or read and in circuit write protection. It is not necessary to provide in circuit write protection without read protection.

This product includes security features that can be used to protect embedded nonvolatile memory contents and prevent execution of unauthorized code. When security is enabled on this device (either by the ordering party or the subsequent receiving parties), the ability of Analog Devices to conduct failure analysis on returned devices is limited. Contact Analog Devices for details on the failure analysis limitations for this device.

Cryptographic Accelerator

The cryptographic accelerator is a 32-bit APB DMA capable peripheral. There are two 128-bit buffers provided for data input/output operations. These buffers read in or read out 128 bits in four data accesses. Big endian and little endian data formats are supported, as are the following modes:

- ECB mode—AES mode
- CTR mode
- CBC mode
- Message authentication code (MAC) mode
- CCM/CCM* mode
- SHA-256 modes
- Protected key storage with key wrap and unwrap—HMAC signature generation

True Random Number Generator (TRNG)

The TRNG is used during operations where nondeterministic values are required. This can include generating challenges for secure communication or keys used for an encrypted communication channel. The generator can run multiple times to generate a sufficient number of bits for the strength of the intended operation. The true random number generator can seed a deterministic random bit generator.

Reliability and Robustness Features

The ADuCM4050 MCU provides several features that can enhance or help achieve certain levels of system safety and reliability. Whereas the level of safety is mainly dominated by system considerations, the following features are provided to enhance robustness.

ECC Enabled Flash Memory

The entire flash array is protected to either correct single-bit errors or detect two bit errors per 64-bit flash data.

Multiparity Bit Protected SRAM

Each word of the SRAM and cache memory is protected by multiple parity bits to allow detection of random soft errors.

Software Watchdog

The on-chip watchdog timer can provide software-based supervision of the ADuCM4050 core.

CRC Accelerator

The CRC accelerator computes the CRC for a block of memory locations, that can be in the SRAM, flash, or any combination of MMRs. The CRC accelerator generates a checksum that can be compared with an expected signature. The main features of the CRC include the following:

- Generates a CRC signature for a block of data.
- Supports programmable polynomial length of up to 32 bits.
- Operates on 32 bits of data at a time, and generates CRC for any data length.
- Supports MSB first and LSB first implementations.
- Various data mirroring capabilities.
- Initial seed to be programmed by user.
- DMA controller (memory to memory transfer) used for data transfer to offload the MCU.

Programmable GPIOs

The ADuCM4050 MCU has 44 and 51 GPIO pins in the LFCSP and WLCSP packages, respectively, with multiple, configurable functions defined by user code. They can be configured as input/output pins and have programmable pull-up resistors. All GPIO pins are functional over the full supply range. In deep sleep modes, GPIO pins retain their state. On reset, they tristate.

Timers

The ADuCM4050 MCU contains three general-purpose timers, a watchdog timer, and an RGB timer. All timers support event capture feature, where they can take 40 different interrupts.

General-Purpose Timers

The ADuCM4050 MCU has three identical general-purpose timers, each with a 16-bit up or down counter. The up or down counter can be clocked from one of four user-selectable clock sources. Any selected clock source can be scaled down using a prescaler of 1, 16, 64, or 256.

Watchdog Timer (WDT)

The watchdog timer (WDT) is a 16-bit count down timer with a programmable prescaler. The prescaler source is selectable and can be scaled by a factor of 1, 16, or 256. The WDT is clocked by the 32 kHz on-chip oscillator (LFOSC) and helps recover from an illegal software state. The WDT requires periodic servicing to prevent it from forcing a reset or interrupt to the MCU.

RGB Timer

The ADuCM4050 MCU has an RGB timer that supports a common anode RGB LED. It has a timer counter and three compare registers. It can generate three distinct pulse width modulation (PWM) waveforms on three GPIO pins simultaneously so different colors can be realized using a common anode RGB LED.

When the RGB timer is in operation, the other three timers are available for user software.

ADC Subsystem

The ADuCM4050 MCU integrates a 12-bit SAR ADC with up to eight external channels. Conversions can be performed in single or autocycle mode. In single mode, the ADC can be configured to convert on a particular channel by selecting one of the ADC channels. Autocycle mode is provided to convert over multiple channels with reduced MCU overhead of sampling and reading individual channel registers. The ADC can also be used for temperature sensing and measuring battery voltage using the ADC channels.

Temperature sensing and battery monitoring cannot be included in autocycle mode.

The digital comparator on the device allows an interrupt to be triggered if ADC input is above or below a programmable threshold. Use the following GPIO multiplexed channels with the digital comparator (see the GPIO Multiplexing section): ADC0_VIN0, ADC0_VIN1, ADC0_VIN2, and ADC0_VIN3.

Use the ADC in DMA mode to reduce MCU overhead by moving ADC results directly into SRAM with a single interrupt asserted when the required number of ADC conversions completely logs to memory. The main features of the ADC subsystem include the following:

- 12-bit resolution.
- Programmable ADC update rate from 10 kSPS to 1.8 MSPS.
- Integrated input mux that supports up to eight channels.
- Temperature sensing support.
- Battery monitoring support.
- Software selectable on-chip reference voltage generation—1.25 V or 2.50 V.
- Software-selectable internal or external reference.
- Autocycle mode provides the ability to automatically select a sequence of input channels for conversion.
- Multiple conversions over a single channel or multiple channels can be performed without core interruption.
- Averaging function—converted data on a single channel or multiple channels can be averaged up to 256 samples.
- Alert function that contains an internal digital comparator for the ADC0_VIN0, ADC0_VIN1, ADC0_VIN2, and ADC0_VIN3 channels. An interrupt is generated if the digital comparator detects an ADC result above or below a user defined threshold. In addition, up to eight cycles of hysteresis are built in.
- Dedicated DMA channel support.
- Each channel, including temperature sensor and battery monitoring, has a data register for conversion result.

Clocking

The ADuCM4050 MCU has the following clocking options:

- High frequency clocks
 - Internal high frequency oscillator (HFOSC) at 26 MHz
 - High frequency external crystal oscillator (HFXTAL) at 26 MHz or 16 MHz
 - GPIO clock in (SYS_CLKIN)
 - Phase-locked loop (PLL)
- Low frequency clocks at 32 kHz
 - Internal low frequency oscillator (LFOSC)
 - Low frequency external crystal oscillator (LFXTAL)

The clock options have software configurability with the following exceptions: the HFOSC cannot be disabled when using an internal buck regulator, and the LFOSC cannot be disabled even if using LFXTAL.

Clock sources with a frequency greater than 26 MHz can be achieved by using a PLL. The maximum frequency sourced from the PLL is 52 MHz.

When core frequency is greater than 26 MHz, program the flash wait states to 1.

As PLL is disabled and relock is transparent to user software, hibernate mode can enter and exit seamlessly when the system frequency is sourced from PLL.

Clock Fail Detection

The LFOSC clock continuously monitors the LFXTAL in hibernate, active, and flexi power modes. If the LFXTAL stops running, there is an option to detect and generate an interrupt and/or automatically switch to the LFOSC without software intervention. The HFOSC clock monitors the HFXTAL clock, GPIO clock, and the PLL clock. If using any of these clocks as the system clock and it fails to toggle, the clock can be detected through an interrupt. There is an option to automatically switch to the HFOSC.

Real-Time Clock (RTC)

The ADuCM4050 MCU has two RTC blocks: RTC0 and RTC1, also called flexible real-time clock (FLEX_RTC™). The RTC blocks share a low power crystal oscillation circuit that operates in conjunction with a 32,768 Hz external crystal.

The RTC has an alarm that interrupts the core when the programmed alarm value matches the RTC count. The software enables and configures the RTC.

The RTC also has a digital trim capability to allow a positive or negative adjustment to the RTC count at fixed intervals.

The FLEX_RTC supports three SensorStrobe outputs: RTC1_SS1, RTC1_SS2, and RTC1_SS3 (see the [ADuCM4050 Ultra Low Power ARM Cortex-M4F MCU with Integrated Power Management Hardware Reference](#)). Using this mechanism, the ADuCM4050 MCU can be used as a programmable clock generator in all power modes except shutdown mode. In this way, the external sensors can have their timing domains mastered by the ADuCM4050 MCU, as the SensorStrobe output is a programmable divider from the FLEX_RTC, which can operate at 0.5 Hz to 16.384 kHz. The sensors and MCU are in sync, which removes the need for additional resampling of data to time align it.

In the absence of the SensorStrobe mechanism, the external sensor uses an RC oscillator (approximately $\pm 30\%$ typical variation). The MCU must sample the data and resample it on the time domain of the MCU before using it.

Alternatively, the MCU remains in a higher power state and drives each data conversion on the sensor side.

The SensorStrobe mechanism allows the ADuCM4050 MCU to be in a lower power state for a long duration and avoids unnecessary data processing, extending the battery life of the end product. The key differences between RTC0 and RTC1 are shown in Table 26.

Table 26. RTC Features

Features	RTC0	RTC1 (FLEX_RTC)
Resolution of Time Base (Prescaling)	Counts time at 1 Hz in units of seconds. Operationally, RTC0 always prescales to 1 Hz (for example, divide by 32,768) and always counts real time in units of seconds.	Can prescale the clock by any power of two from 0 to 15. It can count time in units of any of these 16 possible prescale settings. For example, the clock can be prescaled by 1, 2, 4, 8, ..., 16,384, or 32,768.
Source Clock	LFXTAL.	Depending on the low frequency multiplexer configuration, the RTC is clocked by the LFXTAL or the LFOSC.
Wake-Up Timer	Wake-up time is specified in units of seconds.	Supports alarm times down to a resolution of 30.52 μ s, that is, where the time is specified down to a specific 32 kHz clock cycle.
Number of Alarms	One alarm only. Uses an absolute, nonrepeating alarm time, specified in units of 1 sec.	Two alarms. One absolute alarm time and one periodic alarm, repeating every 60 prescaled time units.
SensorStrobe Mechanism	Not available.	Four independent channels with fine control on duty cycle and frequency (0.5 Hz to 16.384 kHz). SensorStrobe is an alarm function in the RTC that can send an output pulse via GPIOs to an external device to instruct that device to take a measurement or perform some action at a specific time. SensorStrobe events are scheduled at a specific target time relative to the real-time count of the RTC. SensorStrobe can be enabled in active, flexi, and hibernate modes.
Input Capture	Not available.	Input capture takes a snapshot of the RTC real-time count when an external device signals an event via a transition on one of the GPIO inputs to the ADuCM4050 MCU. Typically, an input capture event is triggered by an autonomous measurement or action on such a device, which then signals to the ADuCM4050 MCU that the RTC must take a snapshot of time corresponding to the event. Taking this snapshot can wake up the ADuCM4050 MCU and cause an interrupt to the CPU. The CPU can subsequently obtain information from the RTC on the exact 32 kHz cycle on which the input capture event occurred.
Input Sampling	Not available.	Each SensorStrobe channel has up to three separate GPIO inputs from an external device, which can be sampled based on the output pulse sent to the external device. Each channel can be configured to interrupt the ADuCM4050 MCU when any activity happens on these GPIO inputs from the external device. These inputs can broadcast sensor states such as first in, first out (FIFO) buffer full, switch open, and threshold crossed. This feature allows the ADuCM4050 MCU to remain in a low power state and wake up to process the data only when a specific programmed sequence from an external device is detected.

Beeper Driver

The ADuCM4050 MCU has an integrated audio driver for a beeper. The beeper driver module in the ADuCM4050 MCU generates a differential square wave of programmable frequency. It drives an external piezoelectric sound component with two terminals that connect to the differential square wave output.

The beeper driver consists of a module that can deliver frequencies ranging from 8 kHz to approximately 0.25 kHz; the minimum frequency is determined by the maximum value of a divide register that can be programmed to 127. This results in a beeper frequency of,

$$32.768 \text{ kHz}/127 = 0.25802 \text{ kHz}$$

The beeper driver allows programmable tone durations in 4 ms increments. Pulse (single-tone) and sequence (multitone) modes provide versatile playback options.

In sequence mode, the beeper can be programmed to play any number of tone pairs from 1 to 254 (2 to 508 tones) or be programmed to play forever (until stopped by the user). Interrupts are available to indicate the start or end of any beep, the end of a sequence, or when the sequence is nearing completion.

Debug Capability

The ADuCM4050 MCU supports a 2-wire serial wire debug (SWD) interface and trace feature via a single-wire viewer port. The ADuCM4050 MCU also has a full flash patch and breakpoint (FPB) unit with support for up to six hardware breakpoints.

ON-CHIP PERIPHERAL FEATURES

The ADuCM4050 MCU contains a rich set of peripherals connected to the core via several concurrent high bandwidth buses, providing flexibility in system configuration as well as excellent overall system performance (see Figure 1).

The ADuCM4050 MCU contains high speed serial ports, an interrupt controller for flexible management of interrupts from the on-chip peripherals or external sources, and power management control functions to tailor the performance and power characteristics of the MCU and system to many application scenarios.

Serial Ports (SPORT)

The ADuCM4050 MCU provides two single-direction half SPORTs or one bidirectional full SPORT. The synchronous serial ports provide an inexpensive interface to a wide variety of digital and mixed-signal peripheral devices such as Analog Devices audio codecs, ADCs, and DACs. The serial ports contain two data lines, a clock, and a frame sync. The data lines can be programmed to either transmit or receive, and each data line has a dedicated DMA channel.

Serial port data can be automatically transferred to and from on-chip memory or external memory via dedicated DMA channels. The frame sync and clock can be shared. Some of the

ADCs and DACs require two control signals for their conversion processes. To interface with such devices, SPT0_ACNV and SPT0_BCNV signals are provided. To use these signals, enable the timer enable mode. In this mode, a PWM timer inside the SPORT module generates the programmable SPT0_ACNV and SPT0_BCNV signals.

Serial ports operate in two modes: the standard digital signal processor (DSP) serial mode and timer enable mode.

SPI Ports

The ADuCM4050 MCU provides three SPIs. The SPI is an industry-standard, full duplex, synchronous serial interface that allows eight bits of data to be synchronously transmitted and simultaneously received. Each SPI incorporates two DMA channels that interface with the DMA controller. One DMA channel transmits and the other receives. The SPI on the MCU eases interfacing to external serial flash devices.

The SPI features include the following:

- Serial clock phase mode and serial clock polarity mode
- Loopback mode
- Continuous transfer mode
- Wire-OR'd output mode
- Read command mode for half-duplex operation (transmit followed by receive)
- Flow control support
- Multiple chip select (CS) line support
- CS software override support
- Support for 3-pin SPI

UART Ports

The ADuCM4050 MCU provides two full duplex UART ports that are fully compatible with PC standard UARTs. The UART port provides a simplified UART interface to other peripherals or hosts, supporting full duplex, DMA supported, asynchronous transfers of serial data. The UART port includes support for five to eight data bits, and none, even, or odd parity. A frame is terminated by one, one and a half, or two stop bits.

PC

The ADuCM4050 MCU provides an I²C bus peripheral that has two pins for data transfer. SCL (Pin P0_04) is a serial clock pin and SDA (Pin P0_05) is a serial data pin. The pins are configured in a wire-AND'd format that allows arbitration in a multimaster system. A master device can be configured to generate the serial clock. The frequency is programmed by the user in the serial clock divisor register. The master channel can operate in fast mode (400 kHz) or standard mode (100 kHz).

DEVELOPMENT SUPPORT

Development support for the ADuCM4050 MCU includes documentation, evaluation hardware, and development software tools.

Documentation

The [ADuCM4050 Ultra Low Power ARM Cortex-M4F MCU with Integrated Power Management Hardware Reference](#) details the functionality of each block on the ADuCM4050 MCU. It includes power management, clocking, memories, and peripherals.

The [ADuCM4050 Ultra Low Power ARM Cortex-M4F MCU with Integrated Power Management Hardware Reference](#) can be ordered from any Analog Devices sales office or accessed electronically on the Analog Devices website at www.analog.com.

Hardware

The [EV-COG-AD4050LZ](#) is available to prototype sensor configuration with the ADuCM4050 MCU.

Software

The [EV-COG-AD4050LZ](#) includes a complete development and debug environment for the ADuCM4050 MCU. The device family pack for the ADuCM4050 MCU is provided for the IAR Embedded Workbench for ARM, Keil™, and CrossCore® embedded studio (CCES) environments.

The device family pack also includes operating system (OS) aware drivers and example code for peripherals on the device.

REFERENCE DESIGNS

The [Circuits from the Lab®](#) web page provides the following for the ADuCM4050 reference design:

- Graphical circuit block diagram presentation of signal chains for a variety of circuit types and applications
- Drill down links for components in each chain to selection guides and application information
- Reference designs applying best practice design techniques

SECURITY FEATURES DISCLAIMER

To the knowledge of Analog Devices, the security features, when used in accordance with the data sheet and hardware reference manual specifications, provide a secure method of implementing code and data safeguards. However, Analog Devices does not guarantee that this technology provides absolute security. Accordingly, analog devices hereby disclaims any and all express and implied warranties that the security features cannot be breached, compromised, or otherwise circumvented and in no event is Analog Devices liable for any loss, damage, destruction, or release of data, information, physical property, or intellectual property.

MCU TEST CONDITIONS

The ac signal specifications (timing parameters) appearing in this data sheet include output disable time, output enable time, and others. Timing is measured on signals when they cross the voltage threshold (V_{MEAS}) level as described in Figure 24. All delays (in nanoseconds or microseconds) are measured between the point that the first signal reaches V_{MEAS} and the point that the second signal reaches V_{MEAS} . The value of V_{MEAS} is set to $V_{BAT}/2$. The tester pin electronics is shown in Figure 25.

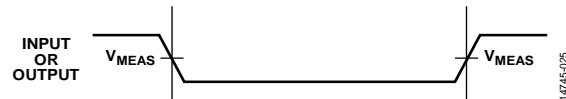
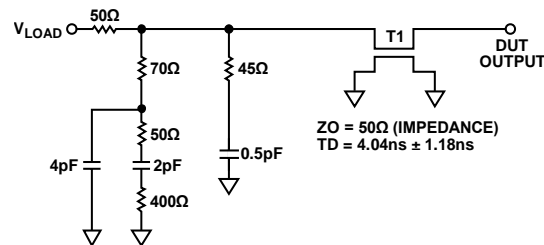

Figure 24. Voltage Reference Levels for AC Measurements (Except Output Enable/Disable)



NOTES

1. THE WORST-CASE TRANSMISSION LINE DELAY (TD) IS SHOWN AND CAN BE USED FOR THE OUTPUT TIMING ANALYSIS TO REFLECT THE TRANSMISSION LINE EFFECT AND MUST BE CONSIDERED. TRANSMISSION LINE IS FOR LOAD ONLY AND DOES NOT AFFECT THE DATA SHEET TIMING SPECIFICATIONS.
2. ANALOG DEVICES RECOMMENDS USING THE IBIS MODEL TIMING FOR A GIVEN SYSTEM REQUIREMENT. IF NECESSARY, A SYSTEM CAN INCORPORATE EXTERNAL DRIVERS TO COMPENSATE FOR ANY TIMING DIFFERENCES.

Figure 25. Equivalent Device Loading for AC Measurements (Includes All Fixtures)

DRIVER TYPES

Table 27 shows the driver types.

Table 27. Driver Types

Driver Type ^{1,2,3}	Associated Pins
Type A	P0_00 to P0_03, P0_07, P0_10 to P0_13, P0_15, P1_00 to P1_10, P1_15, P2_00, P2_01, P2_04 to P2_14, P3_00 to P3_03, and SYS_HWRST
Type B	P0_08, P0_09, P0_14, P1_11 to P1_14, and P2_02
Type C	P0_04 and P0_05
Type D	P0_06

¹ In single drive mode, the maximum source/sink capacity is 2 mA.

² In double drive mode, the maximum source/sink capacity is 4 mA.

³ At maximum drive capacity, only 16 GPIOs are allowed to switch at any given point in time.

EEMBC ULPMARK™-CP SCORE

Using the following software configuration and the profile configuration shown in Table 28, the EEMBC ULPMark-CP score is 189.

- Compiler name and version: IAR EWARM 8.20.1
- Compiler flags:

```
--no_size_constraints --cpu=Cortex-M4 -D
__ADUCM4050__ --no_code_motion -Ohs -e --
fpu=VFPv4_sp --endian=little
```
- ULPBench Profile and Version: Core Profile v1.1
- EnergyMonitor Software Version: V2.0

Table 28. EEMBC ULPMark™-CP Profile Configuration

Profile Configuration	Value
Wake-Up Timer Module	RTC1
Wake-Up Timer Clock Source	External crystal
Wake-Up Timer Frequency	32768 Hz
Wake-Up Timer Accuracy	20 ppm
Active Power Mode Name	Active mode
Active Mode Clock Configuration	52 MHz (CPU), 32 kHz (RTC)
Active Mode Voltage Integrity	1.74 V
Inactive Power Mode Name	Hibernate
Inactive Clock Configuration	Off (CPU), 32 kHz (RTC)
Inactive Mode Voltage Integrity	1.74 V

GPIO MULTIPLEXING

The following tables capture signal multiplexing options for the GPIO pins.

Table 29. Signal Multiplexing for Port 0¹

Pin	Multiplexed Function 0	Multiplexed Function 1	Multiplexed Function 2	Multiplexed Function 3
P0_00	GPIO00	SPIO_CLK	SPT0_BCLK	Not applicable
P0_01	GPIO01	SPIO_MOSI	SPT0_BFS	Not applicable
P0_02	GPIO02	SPIO_MISO	SPT0_BD0	Not applicable
P0_03	GPIO03	SPIO_CS0	SPT0_BCNV	SPI2_RDY
P0_04	GPIO04	I2C0_SCL	Not applicable	Not applicable
P0_05	GPIO05	I2C0_SDA	Not applicable	Not applicable
P0_06	SWD0_CLK	GPIO06	Not applicable	Not applicable
P0_07	SWD0_DATA	GPIO07	Not applicable	Not applicable
P0_08	GPIO08	BPRO_TONE_N	Not applicable	Not applicable
P0_09	GPIO09	BPRO_TONE_P	SPI2_CS1	Not applicable
P0_10	GPIO10	UART0_TX	Not applicable	Not applicable
P0_11	GPIO11	UART0_RX	Not applicable	Not applicable
P0_12	GPIO12	SPT0_AD0	Not applicable	UART0_SOUT_EN
P0_13	GPIO13/SYS_WAKE2	Not applicable	Not applicable	Not applicable
P0_14	GPIO14	TMR0_OUT	SPI1_RDY	Not applicable
P0_15	GPIO15/SYS_WAKE0	Not applicable	Not applicable	Not applicable

¹ Available in WLCSP and LFCSP.

Table 30. Signal Multiplexing for Port 1¹

Pin	Multiplexed Function 0	Multiplexed Function 1	Multiplexed Function 2	Multiplexed Function 3
P1_00	GPIO16/SYS_WAKE1	Not applicable	Not applicable	Not applicable
P1_01	SYS_BMODE0	GPIO17	Not applicable	Not applicable
P1_02	GPIO18	SPI2_CLK	Not applicable	Not applicable
P1_03	GPIO19	SPI2_MOSI	Not applicable	Not applicable
P1_04	GPIO20	SPI2_MISO	Not applicable	Not applicable
P1_05	GPIO21	SPI2_CS0	Not applicable	Not applicable
P1_06	GPIO22	SPI1_CLK	Not applicable	RGB_TMRO_1
P1_07	GPIO23	SPI1_MOSI	Not applicable	RGB_TMRO_2
P1_08	GPIO24	SPI1_MISO	Not applicable	RGB_TMRO_3
P1_09	GPIO25	SPI1_CS0	Not applicable	SWV
P1_10	GPIO26	SPIO_CS1	SYS_CLKIN	SPI1_CS3
P1_11	GPIO27	Not applicable	TMR1_OUT	Not applicable
P1_12	GPIO28	Not applicable	RTC1_SS2	Not applicable
P1_13	GPIO29	TMR2_OUT	Not applicable	Not applicable
P1_14	GPIO30	Not applicable	SPIO_RDY	Not applicable
P1_15	GPIO31	SPT0_ACLK	UART1_TX	Not applicable

¹ Available in WLCSP and LFCSP.

Table 31. Signal Multiplexing for Port 2

Pin	Availability		Multiplexed Function 0	Multiplexed Function 1	Multiplexed Function 2	Multiplexed Function 3
	WLCSP	LFCSP				
P2_00	Yes	Yes	GPIO32	SPT0_AFS	UART1_RX	Not applicable
P2_01	Yes	Yes	GPIO33/SYS_WAKE3	Not applicable	TMR2_OUT	Not applicable
P2_02	Yes	Yes	GPIO34	SPT0_ACNV	SPI1_CS2	Not applicable
P2_03	Yes	Yes	GPIO35	ADC0_VIN0	Not applicable	Not applicable
P2_04	Yes	Yes	GPIO36	ADC0_VIN1	Not applicable	Not applicable
P2_05	Yes	Yes	GPIO37	ADC0_VIN2	Not applicable	Not applicable
P2_06	Yes	Yes	GPIO38	ADC0_VIN3	Not applicable	Not applicable
P2_07	Yes	Yes	GPIO39	ADC0_VIN4	SPI2_CS3	Not applicable
P2_08	Yes	Yes	GPIO40	ADC0_VIN5	SPI0_CS2	RTC1_SS3
P2_09	Yes	Yes	GPIO41	ADC0_VIN6	SPI0_CS3	Not applicable
P2_10	No	Yes	GPIO42	ADC0_VIN7	SPI2_CS2	Not applicable
P2_11	Yes	Yes	GPIO43	SPI1_CS1	SYS_CLKOUT	RTC1_SS1
P2_12	Yes	No	GPIO44	UART1_TX	SPI2_CS3	Not applicable
P2_13	Yes	No	GPIO45	UART1_RX	SPI0_CS2	Not applicable
P2_14	Yes	No	GPIO46	SPI0_CS3	Not applicable	Not applicable
P2_15	Yes	No	GPIO47	SPI2_CS2	SPI1_CS3	SPI0_CS1

Table 32. Signal Multiplexing for Port 3¹

Pin	Multiplexed Function 0	Multiplexed Function 1	Multiplexed Function 2	Multiplexed Function 3
P3_00	GPIO48	RGB_TMR0_1	SPT0_ACLK	Not applicable
P3_01	GPIO49	RGB_TMR0_2	SPT0_AFS	Not applicable
P3_02	GPIO50	RGB_TMR0_3	SPT0_AD0	Not applicable
P3_03	GPIO51	Not applicable	SPT0_ACNV	Not applicable

¹ Only available in WLCSP.

APPLICATIONS INFORMATION

This section contains circuit diagrams that show the recommended external components for proper operation of the ADuCM4050 in example application scenarios.

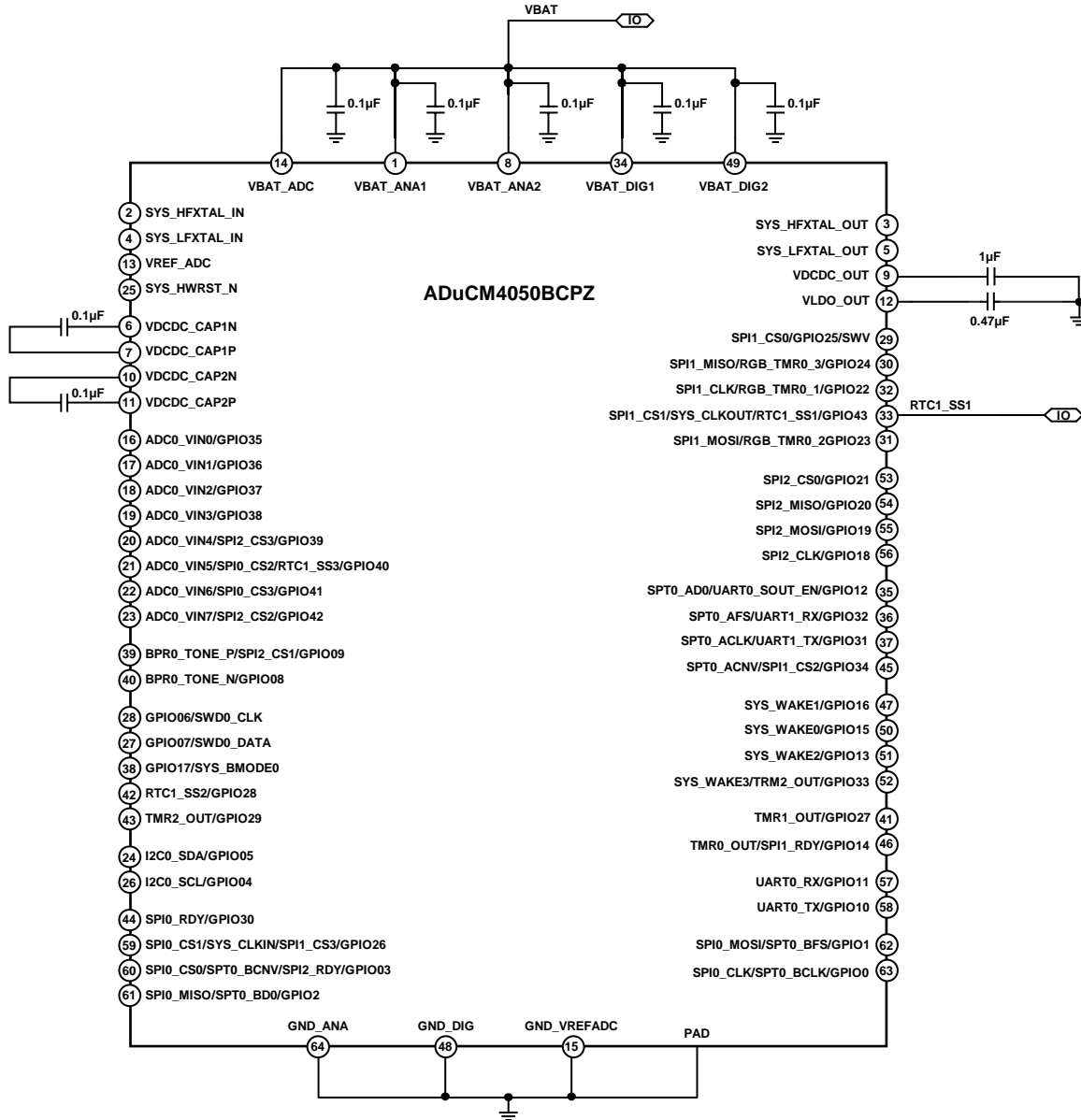

Figure 26. Recommended External Components when Using the Internal Buck Converter

147745-100

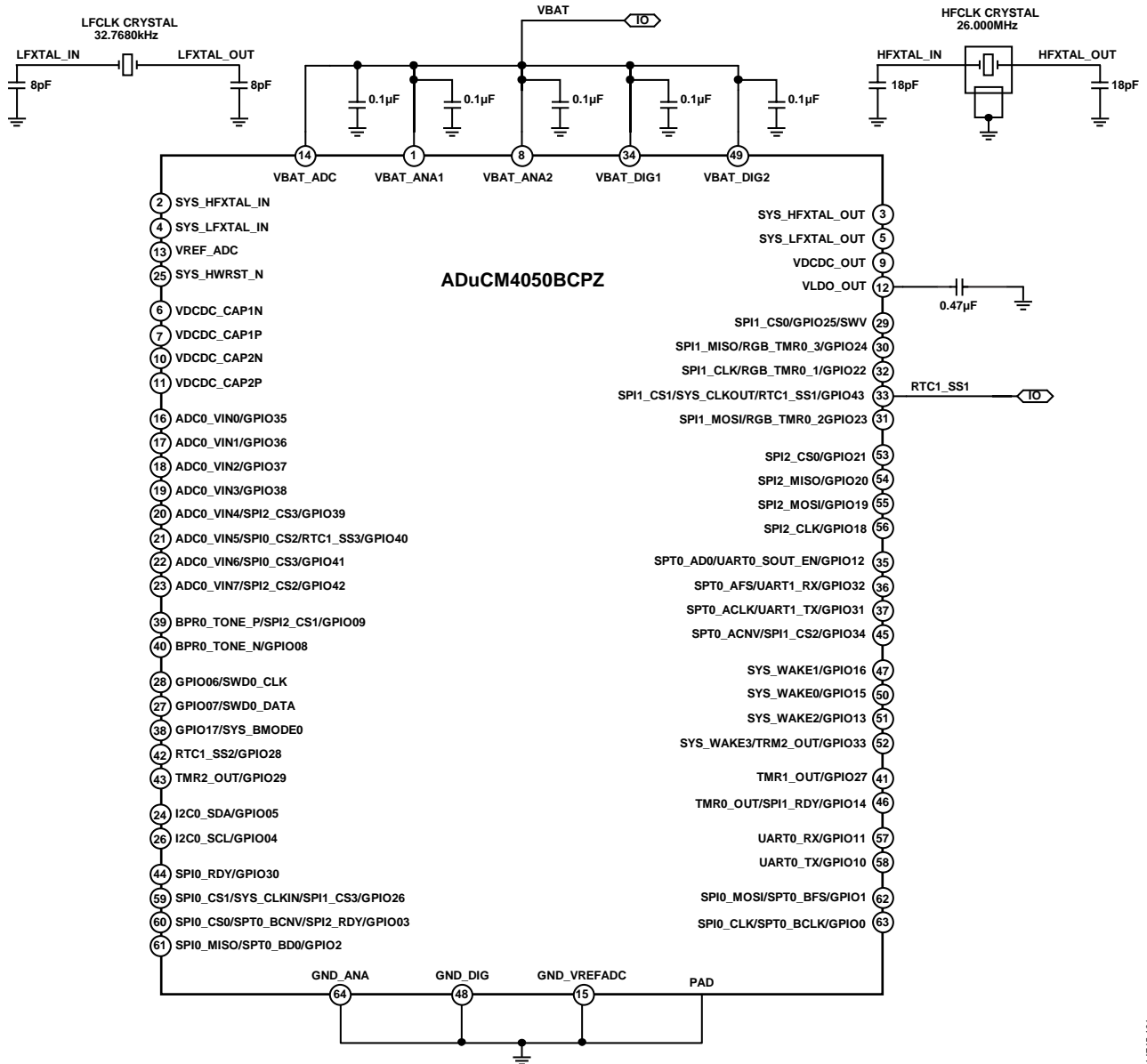

Figure 27. Recommended External Components when Using LFXTAL and HFXTAL

14745-101

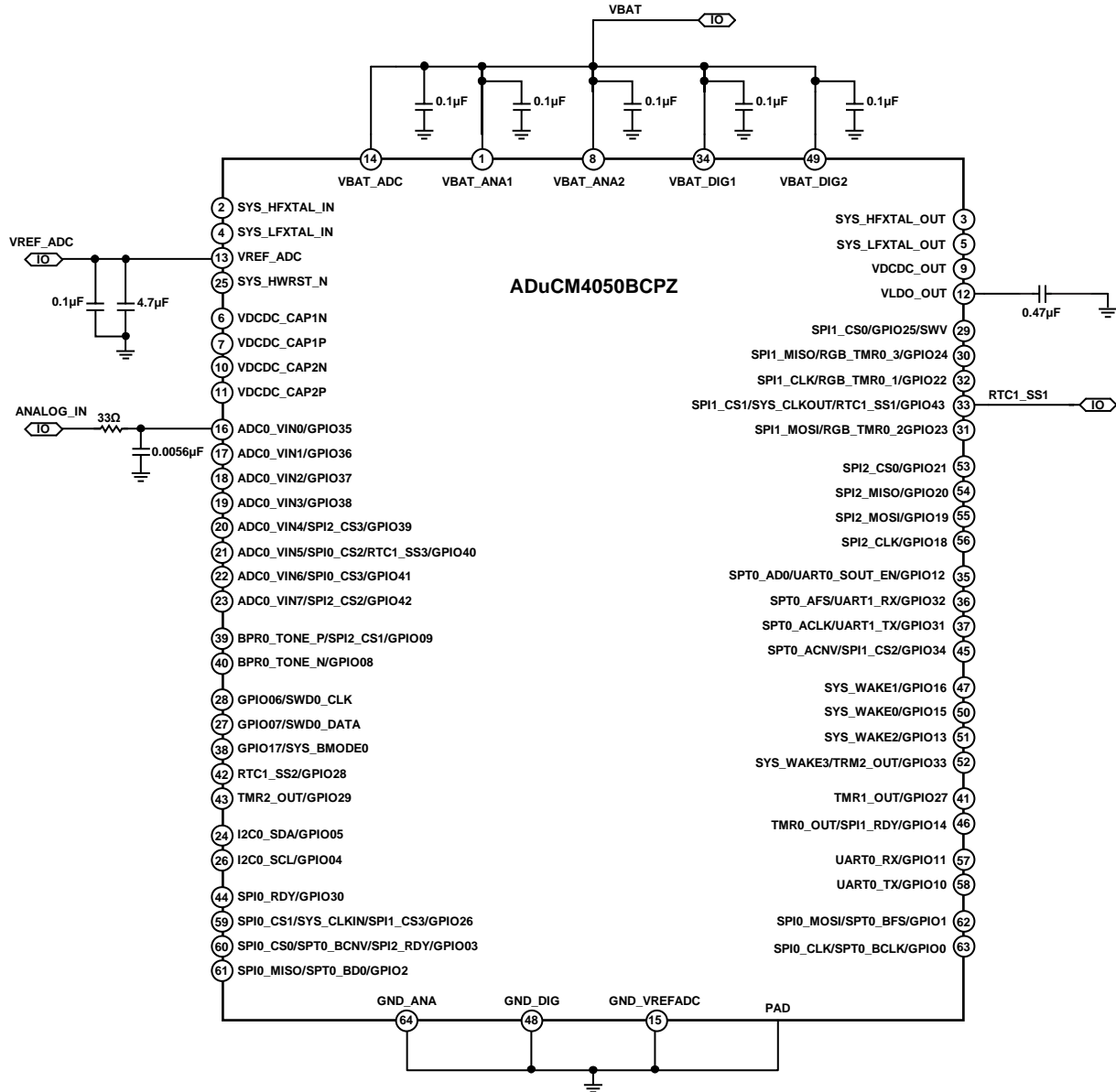

Figure 28. Recommended External Components on VREF_ADC Pin and ADC Input Channel (ADC0_VIN0 Used as Example) when Using the Internal ADC

14745-102

SILICON ANOMALY

This anomaly list describes the known bugs, anomalies, and workarounds for the ADuCM4050. These anomalies represent the currently known differences between revisions of the ADuCM4050 product and the functionality specified in the ADuCM4050 data sheet and the hardware reference manual.

Analog Devices, Inc., is committed, through future silicon revisions, to continuously improve silicon functionality. Analog Devices tries to ensure that these future silicon revisions remain compatible with your present software/systems by implementing the recommended workarounds outlined here.

ADuCM4050 FUNCTIONALITY ISSUES

Silicon Revision Identifier	Silicon Status	No. of Reported Anomalies
0.1	Released	3 (21000011, 21000016, 21000017)

A silicon revision number with the form x.y is branded on all devices. The silicon revision can be electronically determined by reading Bits[3:0] of the SYS_CHIPID register. SYS_CHIPID = 0x1 indicates Silicon Revision 0.1, and SYS_CHIPID = 0x0 indicates Silicon Revision 0.0.

FUNCTIONALITY ISSUES

Table 33. 21000011—I²C Master Mode Fails to Generate Clock when Clock Dividers are Too Small

Issue	When the I ² C clock dividers are configured in master mode such that the sum of the low and high bit fields in the I2C_DIV register is less than 16, the I ² C fails to generate a clock.
Workaround	Program the I ² C clock dividers such that I2C_DIV.LOW + I2C_DIV.HIGH ≥ 16.
Revision	0.1

Table 34. 21000016—Possible Receive Data Loss with I²C Automatic Clock Stretching

Issue	When the I ² C Rx FIFO is full and new I ² C data is received, a data overflow occurs. When automatic clock stretching is enabled, the transaction is paused by holding the SCL (Pin P0_04) line low. This function works as expected when the next read happens after the clock is stretched (that is, after the overflow is detected). However, if the read occurs after the last bit of the I ² C data is received but before the clock is stretched, the received data is not written to the Rx FIFO and is lost.
Workaround	When I ² C automatic clock stretching is enabled, read the FIFO should only after the overflow flag is set in the status register to ensure that that Rx FIFO is never read at the same time that the overflow is asserted.
Revision	0.1

Table 35. 21000017—SPI Read Command Mode Does Not Work Properly when SPI_CNT is 1 and DMA is Enabled

Issue	When SPI master is enabled and uses the DMA mode with SPI_CNT = 1, the read command mode may not function properly. Consider the following configurations: SPI_RD_CTL = 0x07; SPI_CNT = 1; the transmit and receive DMA channels are configured for 1 half-word. In this configuration, the read command sent in the first byte on the MOSI output is repeated in the second byte (in the address slot). Therefore, the slave device responds on the MISO line with whatever content is at the address equivalent to the read command value (for example, if the read command is 0xB, the response is the data read from Slave Address 0xB).
Workaround	The following workarounds can be used. Utilize the overlap mode to align the transmit/receive SPI operations and discard the junk bytes, as follows: <ol style="list-style-type: none"> Set SPI_RD_CTL.OVERLAP = 1 to enable overlap mode. Set SPI_RD_CTL.TXBYTES = 1 to configure a single transmit byte (8-bit address register). Set SPI_CNT.VALUE = 3 to configure the transfer count: one byte for the address register, one byte for the command, and one dummy byte to obtain the read value. On the receive side, discard the first two junk bytes received during the transfer of the address and command bytes before processing the actual read value in the third byte. Alternatively, do not use Tx DMA operation on the SPI transmit side, by taking the following steps: <ol style="list-style-type: none"> Enable only SPI RX DMA requests. Fill the SPI Tx FIFO by using core accesses to write the SPI_TX register. Perform a dummy read of the SPI_RX register to kick off the SPI transfers.
Revision	0.1

SECTION 1. ADuCM4050 FUNCTIONALITY ISSUES

Reference No.	Description	Status
21000011	I ² C master mode fails to generate clock when clock dividers are too small	Identified
21000016	Possible receive data loss with I ² C automatic clock stretching	Identified
21000017	SPI read command mode does not work properly when SPI_CNT is 1 and DMA is enabled	Identified

This completes the Silicon Anomaly section.

OUTLINE DIMENSIONS

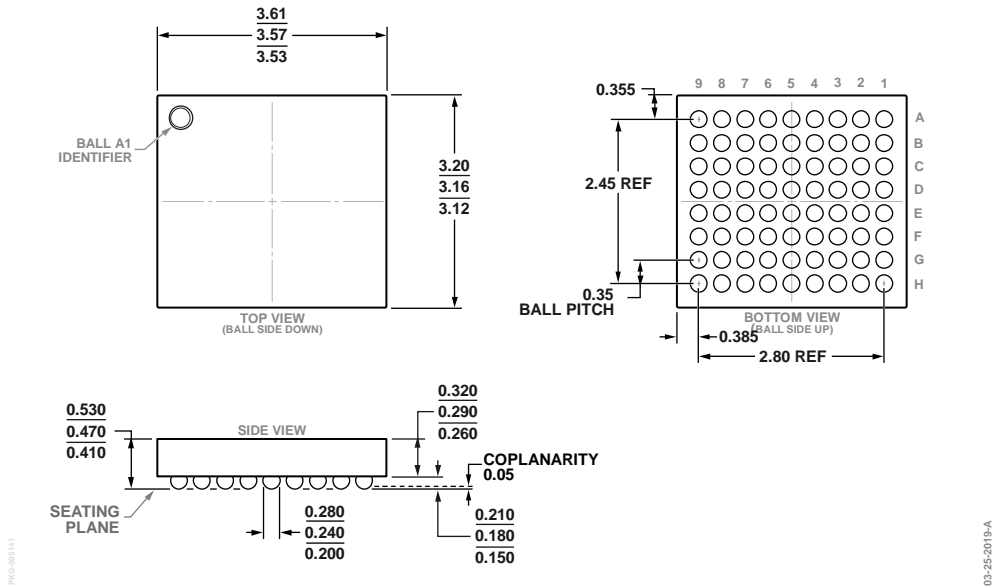
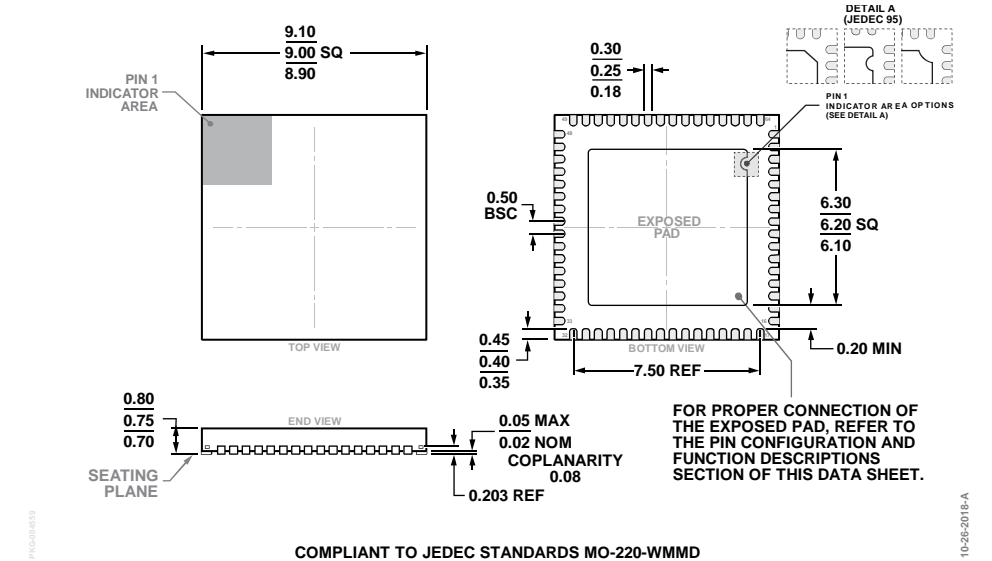

Figure 29. 72-Ball Wafer Level Chip Scale Package [WLCSP] (CB-72-3)
Dimensions shown in millimeters



COMPLIANT TO JEDEC STANDARDS MO-220-WMMD
Figure 30. 64-Lead Lead Frame Chip Scale Package [LFCSP] 9 mm x 9 mm Body and 0.75 mm Package Height (CP-64-17)
Dimensions shown in millimeters