

## VN7050AS evaluation board

Data brief

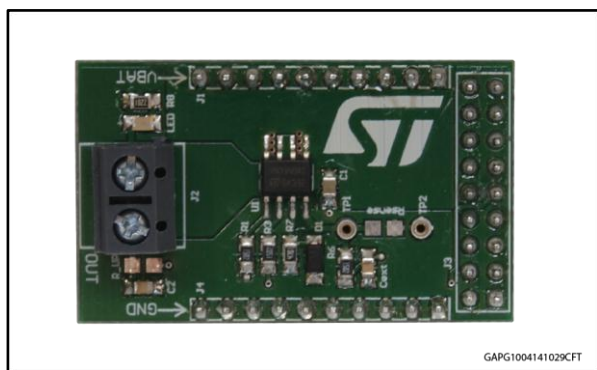

### Features

Max transient supply voltage	$V_{CC}$	40 V
Operating voltage range	$V_{CC}$	4 to 28 V
Typ. on-state resistance (per Ch)	$R_{ON}$	50 m $\Omega$
Current limitation (typ)	$I_{LIMH}$	30 A
Stand-by current (max)	$I_{STBY}$	0.5 $\mu$ A

- Simple single IC application board dedicated for VN7050AS
- Provides electrical connectivity and thermal heat-sinking for easy prototyping
- General device features
  - Single channel smart high side driver with analog feedback
  - Very low standby current

- Compatible with 3 V and 5 V CMOS outputs
- Diagnostic functions
  - Dedicated high precision proportional load current sense
  - Overload and short to ground (power limitation) indication
  - Thermal shutdown indication
  - OFF-state open-load detection
  - Output short to  $V_{CC}$  detection
  - Sense enable/disable
- Protections
  - Undervoltage shutdown
  - Overvoltage clamp
  - Load current limitation
  - Self limiting of fast thermal transients
  - Loss of ground and loss of  $V_{CC}$
  - Reverse battery with external components
  - Electrostatic discharge protection

### Applications

Typical applications are all types of automotive resistive, inductive and capacitive loads.

**Table 1: Device summary**

Order code	Reference
EV-VN7050AS	VN7050AS evaluation board

# 1 Description

This board provides you an easy way to connect STMicroelectronics® VIPower® M0-7 technology into your existing system.

It comes pre-assembled with VN7050AS high-side driver. On board minimum set of electrical components (as for device datasheet recommendation) is enabling the user to directly connect the load, the power supply and the microcontroller without any additional effort in external component design and connection.

The VN7050AS is a single channel high-side driver manufactured using ST proprietary VIPower technology and housed in SO-8 package. The device is designed to drive 12 V automotive grounded loads through a 3 V and 5 V CMOS-compatible interface and to provide protection and diagnostics.

The device integrates also advanced protective functions such as load current limitation, overload active management by power limitation and overtemperature shutdown.

A dedicated high precision proportional load current sense is available, in addition to the detection of overload and short circuit to ground, short to V<sub>CC</sub> and OFF-state open-load.

A sense enable pin allows OFF-state diagnosis to be disabled during the module low-power mode as well as external sense resistor sharing among similar devices.

Figure 1: Evaluation board schematic

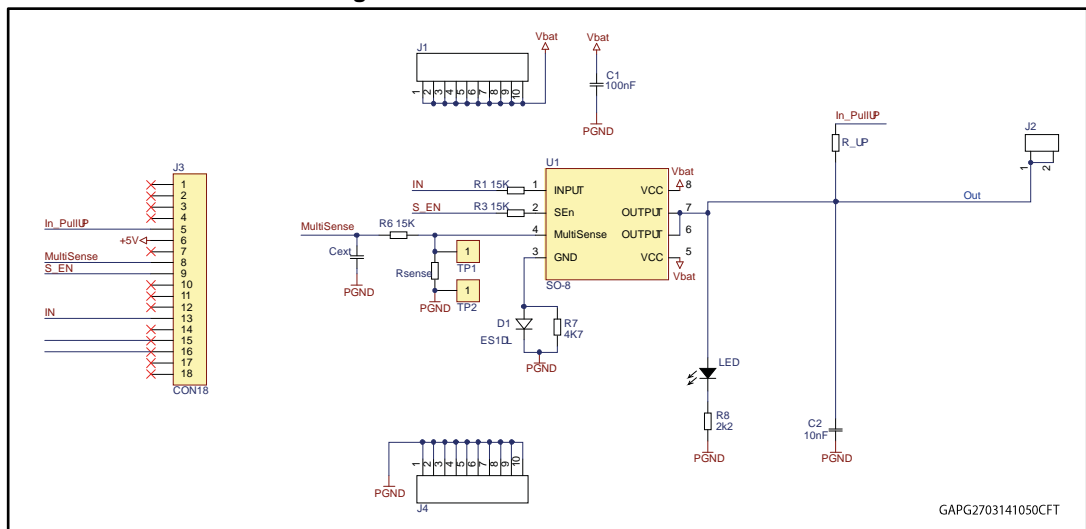

GAPG2703141050CFT

## 2 Board connections

Figure 2: "Evaluation board connections" shows the placement of the connectors to be used for supplying the evaluation board, connecting the load and controlling the functionality and diagnostic of the device.

Figure 2: Evaluation board connections

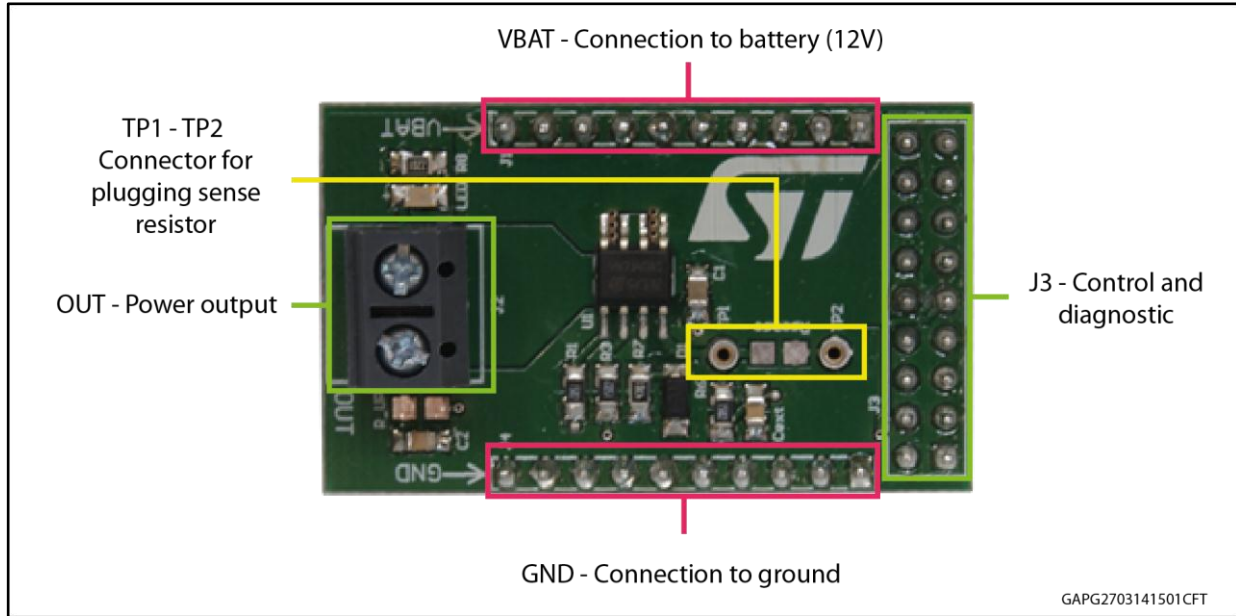

GAPG2703141501CFT

Table 2: J3 connector: pin functions

Connector	Pin number	Pin name	Pin function
J3	1...4	N/A	Not connected
J3	5	IN_PullUP	Connection to optional external pull-up resistor for open load detection in off-state.
J3	6	+5V	5 V Power Supply
J3	7	N/A	Not connected
J3	8	MultiSense	Current Sense pin: it delivers a current proportional to load current
J3	9	S_EN	Active high compatible with 3 V and 5 V CMOS outputs pin; it enables the MultiSense diagnostic pin.
J3	10...12	N/A	Not connected
J3	13	IN	Voltage controlled input pin with hysteresis, compatible with 3 V and 5 V CMOS outputs. It controls OUT switch state.
J3	14...18	N/A	Not connected

In case the user wishes to utilize the Current Sense/MultiSense function of the device, it is necessary to plug a sense resistor in  $R_{SENSE}$ .

The package includes a through-hole resistor, to be mounted on TP1-TP2 (see [Figure 4: "Mounting through-hole sense resistor"](#)).

Different  $R_{\text{SENSE}}$  values can be adopted based on user preference.

Another option is soldering an SMD resistor on the dedicated PCB pad, as shown in [Figure 5: "Pads for soldering SMD resistor"](#).

**Figure 3: No sense resistor**



**Figure 4: Mounting through-hole sense resistor**

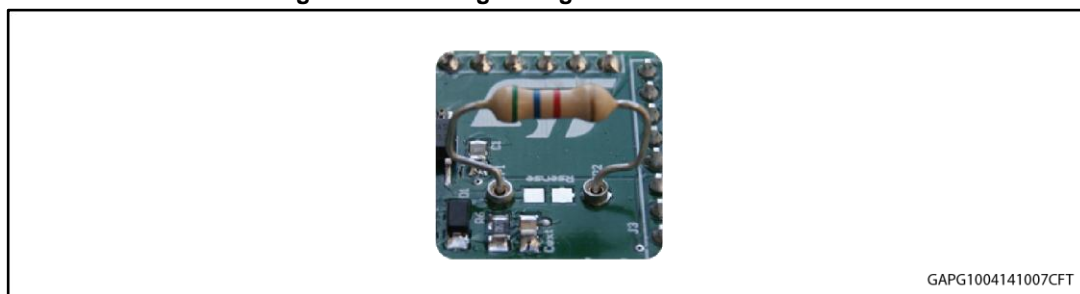

**Figure 5: Pads for soldering SMD resistor**

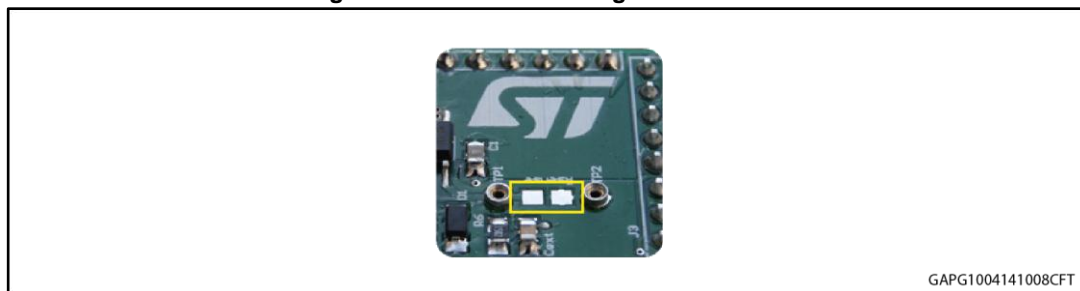

### 3 Thermal data

Table 3: Thermal data

Symbol	Parameter	Max	Unit
$R_{thj-amb}$	Thermal resistance junction-ambient (MAX)	64	°C/W

Table 4: PCB specifications

Parameter	Value
Board dimensions	25 mm x 41.5 mm
Number of Cu layer	2
Layer Cu thickness	35 $\mu$ m
Board finish thickness	1.6 mm +/- 10%
Board Material	FR4
Thermal vias separation	1.1 mm
Thermal vias diameter	0.5 mm

## 4 Revision history

Table 5: Revision history

Date	Revision	Changes
01-Oct-2014	1	Initial release.
03-Sep-2015	2	Changed EV-VN7050AS-E in EV-VN7050AS. Updated <a href="#">Section "Features"</a> and <a href="#">Section 1: "Description"</a>