

VNH7100AS Evaluation Board

Data brief

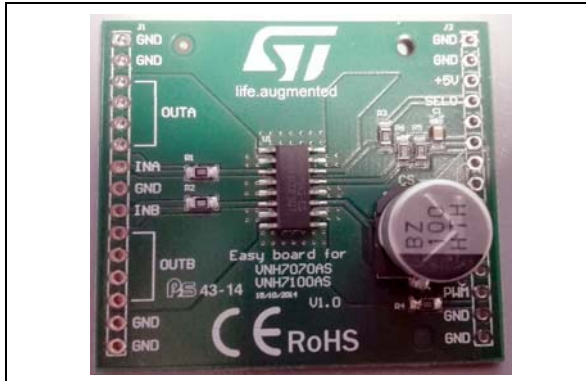

additional effort in external component design and connection.

VNH7100AS is a full bridge motor driver intended for a wide range of automotive applications. The device incorporates a dual monolithic high-side driver and two low-side switches. Both switches are designed using ST proprietary VIPower M0 technology that allows to efficiently integrate on the same die a true Power MOSFET with an intelligent signal/protection circuitry. The three dies are assembled in SO-16N package on electrically isolated leadframes.

Moreover, its fully symmetrical mechanical design allows superior manufacturability at board level.

The input signals INA and INB can directly interface the microcontroller to select the motor direction and the brake condition. A SEL0 pin is available to address the information available on the MultiSense to the microcontroller. The MultiSense pin allows to monitor the motor current by delivering a current proportional to the motor current value.

The PWM, up to 20 kHz, allows to control the speed of the motor in all possible conditions.

Features

Max transient supply voltage	V_{CC}	41 V
Operating voltage range	V_{CC}	4 to 28 V
Typ. on-state resistance (per Ch)	R_{ON}	100 m Ω
Current limitation (typ)	I_{LIMH}	15 A
Stand-by current (max)	I_{STBY}	1 μ A

- Simple single IC application board dedicated for VNH7100AS
- Provides electrical connectivity and thermal heat-sinking for easy prototyping

Description

EV-VNH7100AS provides you an easy way to connect STMicroelectronics® VIPower® M0-7 H-Bridge drivers into your existing prototype circuitry. This evaluation board comes preassembled with VNH7100AS H-Bridge. On board minimum set of electrical components (as for device datasheet recommendation) is enabling the user to directly connect the load, the power supply and the microcontroller without any

Table 1. Device summary

Order Code	Reference
EV-VNH7100AS	VNH7100AS Evaluation Board

1 Design recommendation

This evaluation board provides mounting and some heat sinking capability for prototype development.

Figure 1. VNH7100AS evaluation board schematic

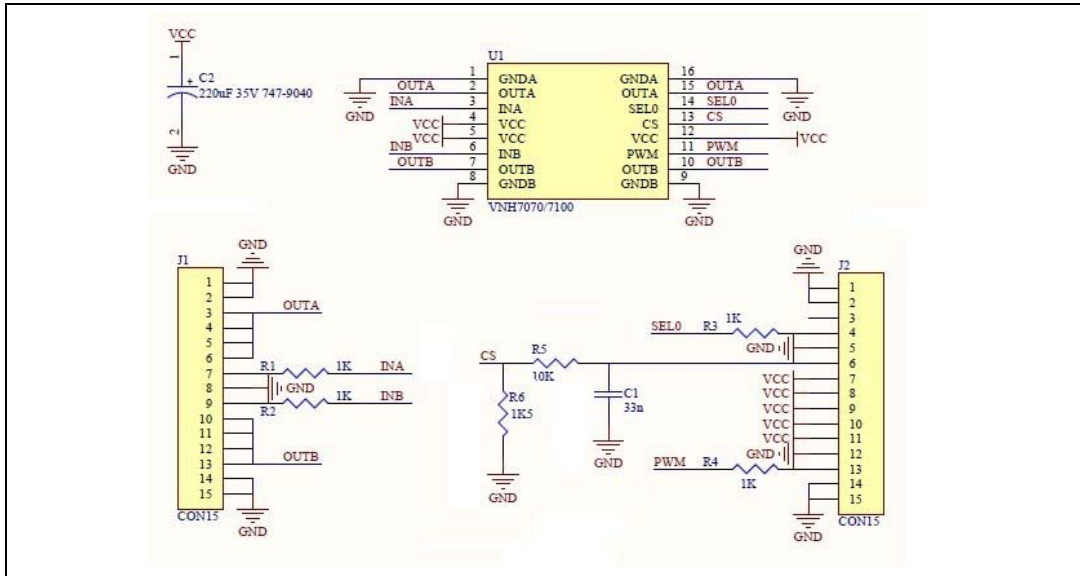

Figure 2. VNH7100AS evaluation board top layout

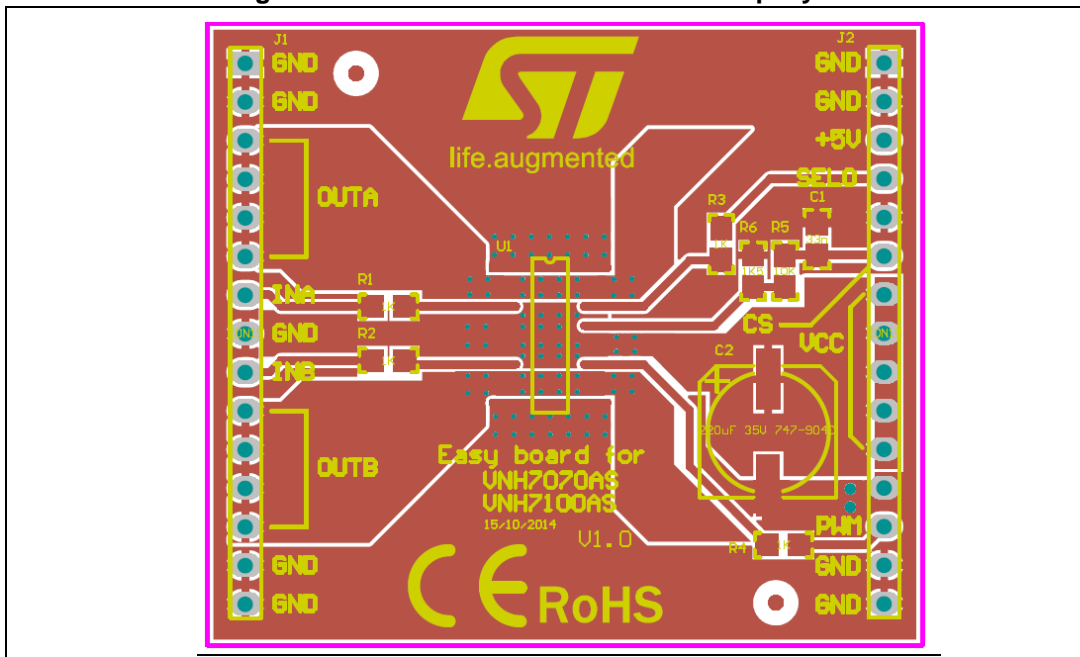
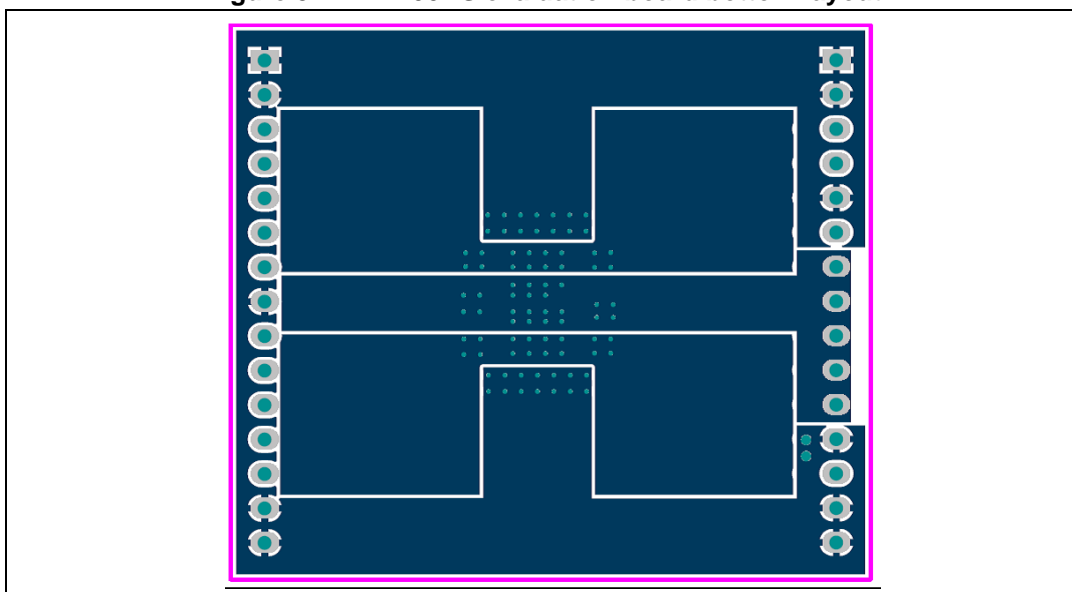

Figure 3. VNH7100AS evaluation board bottom layout



2 Board connections

Table 2. Pin connection and function

Connector	Board lead number	Device pin function
J1	1, 2	GND
J1	3, 4, 5, 6	OUTA
J1	7	INA
J1	8	GND
J1	9	INA
J1	10, 11, 12, 13	OUTB
J1	14, 15	GND
J2	1, 2	GND
J2	4	SEL0
J2	5	GND
J2	6	CS
J2	7, 8, 9, 10, 11	VCC
J2	12	GND
J2	13	PWM
J2	14, 15	GND

Table 3. BOM

Component	Value
C1	33 nF
C2	220 uF 35V
R1, R2,R3, R4	1k Ohm
R5	10K Ohm
R6	1.5k Ohm

3 Thermal data

Table 4. EV-VNH7100AS thermal data

Symbol	Parameter	Max	Unit
Rthj-amb	Thermal resistance junction-ambient HSD (MAX)	55	°C/W
Rthj-amb	Thermal resistance junction-ambient HSD (MAX)	75	°C/W

Table 5. PCB specifications

Parameter	Value	Unit
Board dimensions	47 x 41	mm
Number of Cu layer	2	-
Layer Cu thickness	35	µm
Board finish thickness	1.6 +/- 10%	mm
Board Material	FR4	-
Thermal vias separation	1.1 mm	
Thermal vias diameter	0.5 mm	

4 Package information

4.1 ECOPACK[®] packages

In order to meet environmental requirements, ST offers these devices in different grades of ECOPACK[®] packages, depending on their level of environmental compliance. ECOPACK[®] specifications, grade definitions and product status are available at: www.st.com. ECOPACK[®] is an ST trademark.

5 Revision history

Table 6. Document revision history

Date	Revision	Changes
26-Oct-2016	1	Initial release.