

Features

Parameter	Symbol	Value	Unit
Max transient supply voltage	V_{CC}	41	V
Operating voltage range	V_{CC}	4.5 to 28	V
Max On-State resistance	R_{ON}	160	m Ω
Current limitation (typ)	I_{LIMH}	10	A
Off-state supply current	I_S	2	$\mu A^{(1)}$

1. Typical value with all loads connected.

- Simple single IC application board dedicated for VNQ5E160K-E
- Provides thermal heat-sinking for ease of use in prototyping
- Provides electrical connectivity for easy prototyping

Description

EV-VNQ5E160K provides you an easy way to connect ST's surface mounted VIPower[®] drivers into your existing prototype circuitry. This evaluation board comes pre-assembled with VNQ5E160K-E high-side driver.

The VNQ5E160K-E is a quad channel high-side driver manufactured using ST proprietary VIPower M0-5 technology and housed in PowerSSO-24 package. The VNQ5E160K-E is designed to drive automotive grounded loads, providing protection, diagnostics and easy 3 V and 5 V CMOS-compatible interface with any microcontroller.

The device integrates advanced protective functions such as load current limitation, inrush and overload active management by power limitation, overtemperature shut-off with auto-restart and overvoltage active clamp. A dedicated

active low digital status pin is associated with every output channel that provides enhanced diagnostic functions including fast detection of overload and short-circuit to ground, overtemperature indication, short-circuit to V_{CC} diagnosis and ON-state and OFF-state open-load detection.

The diagnostic feedback of the whole device can be disabled by pulling the STAT_DIS pin up, thus allowing wired-ORing with similar devices.

Figure 1. VNQ5E160K evaluation board

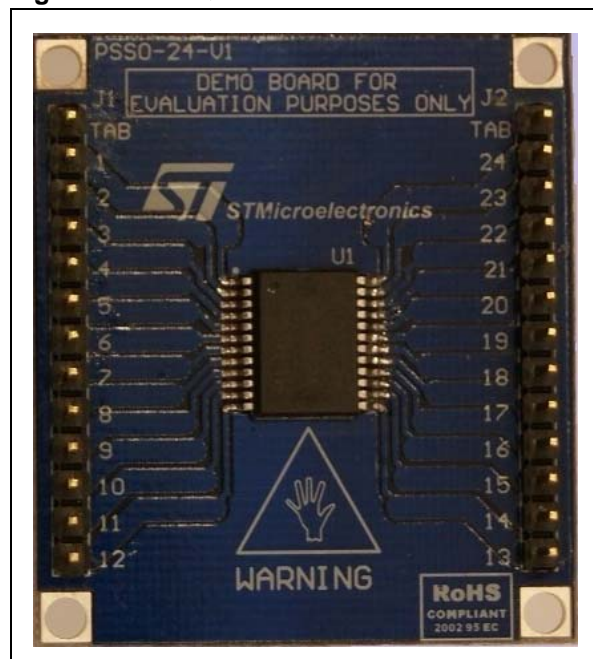

Table 1. Device summary

Order code	Reference
EV-VNQ5E160K	VNQ5E160K evaluation board

1 Design recommendations

This evaluation board provides mounting solution and some heat sinking capability for prototype development, but there are still external components that are required to make these devices work in any application. For further information on how the evaluation board has to be used you can refer to the AN4212 (see [Appendix A: Reference documents](#)).

[Figure 2](#) illustrates the necessary components for any application.

Figure 2. VNQ5E160K evaluation board

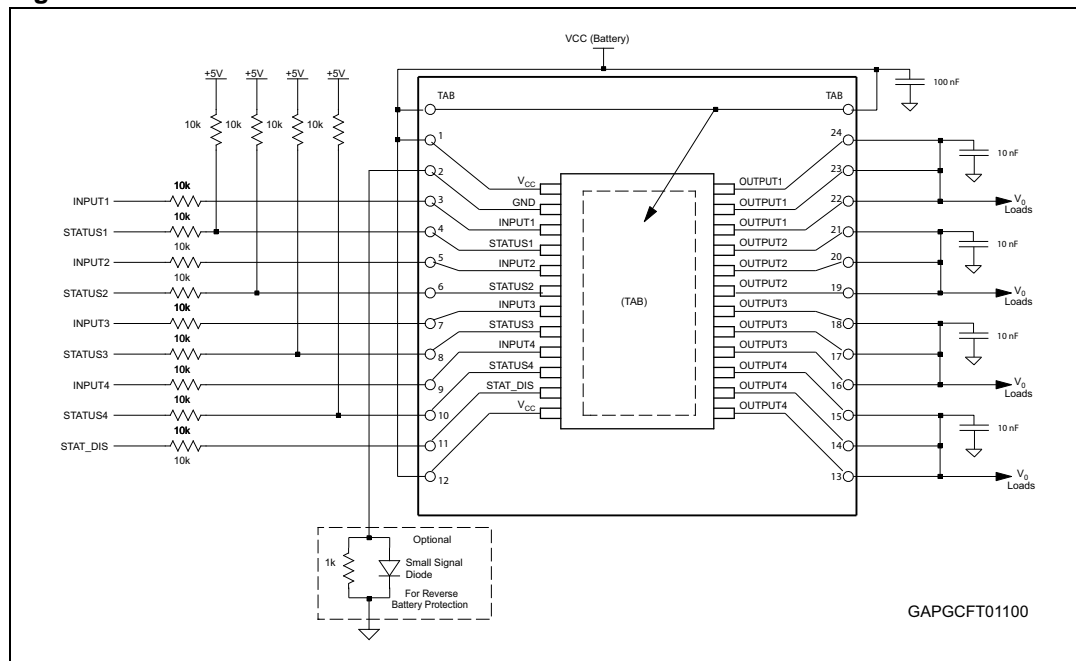

ST has produced a user manual for safe designs using ST's VIPower devices. This is UM1556 (see [Appendix A: Reference documents](#)). UM1556 is a VIPower Hardware design guide that provides all necessary information to successfully design your circuit using our VIPower drivers.

All designs have different needs and requirements. Whatever design you decide to use, it will still need to be verified in order to meet your application specifications. ST implies no guarantee or warranty (see [Appendix A: Reference documents](#)).

2 Thermal data

Table 2. VNQ5E160K-E thermal data

Symbol	Parameter	Max. value	Unit
$R_{thj-amb}$	Thermal resistance junction-ambient (MAX)	30.5	°C/W

Table 3. PCB specifications

Parameter	Value	Unit
Board dimensions	38 x 43	mm
Number of Cu layer	2	—
Layer Cu thickness	70	μm
Board finish thickness	1.6 +/- 10%	mm
Board Material	FR4	—
Thermal vias separation	1.2	mm
Thermal vias diameter	0.3 /- 0.08	mm

3 Board connector reference

Figure 3. Board layout

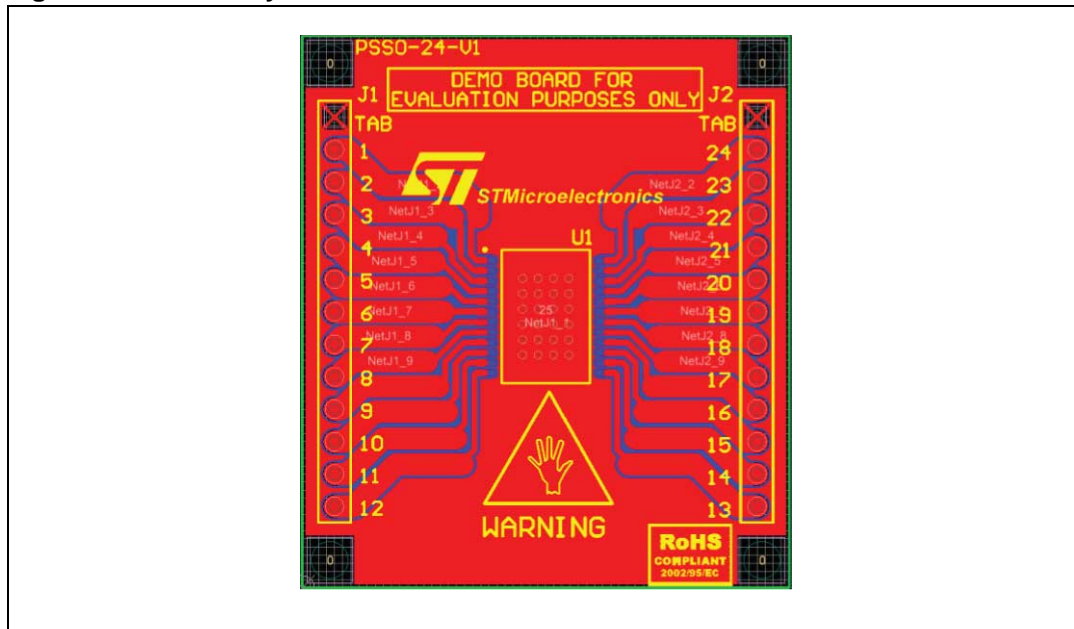

Table 4. Board connector specification

Connector	Board lead number	Device pin function ⁽¹⁾
J1	TAB	V _{CC}
J1	1	V _{CC}
J1	2	GND
J1	3	INPUT1
J1	4	STATUS1
J1	5	INPUT2
J1	6	STATUS2
J1	7	INPUT3
J1	8	STATUS3
J1	9	INPUT4
J1	10	STATUS4
J1	11	STAT_DIS
J1	12	V _{CC}
J2	TAB	V _{CC}
J2	13	OUTPUT4
J2	14	OUTPUT4
J2	15	OUTPUT4

Table 4. Board connector specification (continued)

Connector	Board lead number	Device pin function ⁽¹⁾
J2	16	OUTPUT3
J2	17	OUTPUT3
J2	18	OUTPUT3
J2	19	OUTPUT2
J2	20	OUTPUT2
J2	21	OUTPUT2
J2	22	OUTPUT1
J2	23	OUTPUT1
J2	24	OUTPUT1

1. For further clarification on pin functions please refer to the related datasheet (see [Appendix A: Reference documents](#)).

4 Package information

4.1 ECOPACK[®] packages

In order to meet environmental requirements, ST offers these devices in different grades of ECOPACK[®] packages, depending on their level of environmental compliance. ECOPACK[®] specifications, grade definitions and product status are available at: www.st.com.

ECOPACK[®] is an ST trademark.

Appendix A Reference documents

1. Quad channel high side driver for automotive applications (VNQ5E160K-E, DocID 14471)
2. VIPower M0-5 and M0-5Enhanced high-side drivers (UM1556, DocID 023520)
3. PowerSSO-24 devices evaluation board (AN4212, DocID 023983)
4. Evaluation Product Licence Agreement on www.st.com

Revision history

Table 5. Document revision history

Date	Revision	Changes
29-Nov-2012	1	Initial release.
16-Sep-2013	2	Updated disclaimer.