

DESCRIPTION

The EV158-J-00A Evaluation Board is designed to demonstrate the capabilities of MP158. The MP158 is a primary-side constant voltage regulator providing accurate constant voltage (CV) regulation without Opto-coupler. It supports Buck, Buck-Boost, Boost and Flyback topologies.

The EV158-J-00A Evaluation Board is designed as Buck application. EV158-J-00A typically drives 5V/50mA load from 85VAC to 145VAC, at 60/50Hz.

The EV158-J-00A has an excellent efficiency and meets IEC61000-4-5 surge immunity and EN55022 conducted EMI requirements. MP158 features various protections, including thermal shutdown (TSD), VCC under-voltage lockout (UVLO), over-load protection (OLP), short-circuit protection (SCP), and open loop protection.

MP158 is available in TSOT23-5 and SOIC8 package.

ELECTRICAL SPECIFICATION

Parameter	Symbol	Value	Units
Input Voltage	V_{IN}	85 to 145	VAC
Output Voltage	V_{OUT}	5	V
Output Current	I_{OUT}	50	mA

FEATURES

- Primary-Side non-isolated Constant Voltage (CV) Control
- Integrated 500V/20Ω MOSFET
- < 100mW No-load power consumption
- Peak-Current Control with Peak Current Compression
- Low VCC operating current
- Limited Maximum Frequency
- Frequency Foldback
- Multiple protections: SCP, OCP, OTP, and VCC UVLO
- Low cost and simple circuit
- Internally biased VCC

APPLICATIONS

- Home appliance, and consumer electronics
- Home automation
- Standby power

All MPS parts are lead-free and adhere to the RoHS directive. For MPS green status, please visit MPS website under Quality Assurance. "MPS" and "The Future of Analog IC Technology", are Registered Trademarks of Monolithic Power Systems, Inc.



Warning: Although this board is designed to satisfy safety requirements, the engineering prototype has not been agency approved. Therefore, all testing should be performed using an isolation transformer to provide the AC input to the prototype board.

EV158-J-00A EVALUATION BOARD

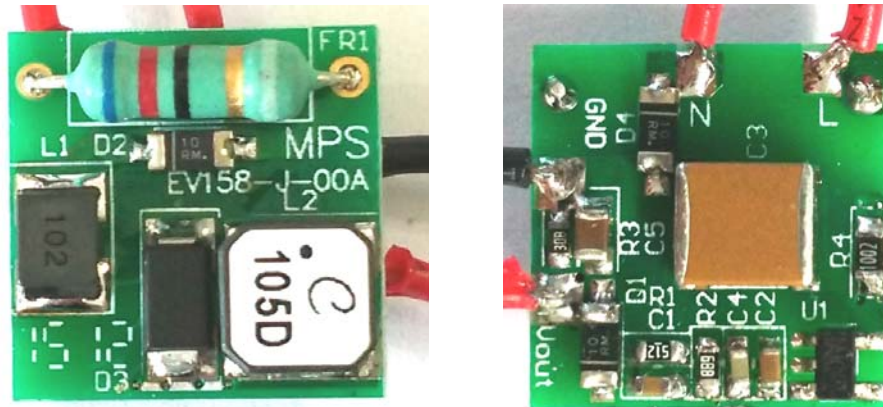

(L x W x H) 15mm x 15mm x 8mm

Board Number	MPS IC Number
EV158-J-00A	MP158GJ

EVALUATION BOARD SCHEMATIC

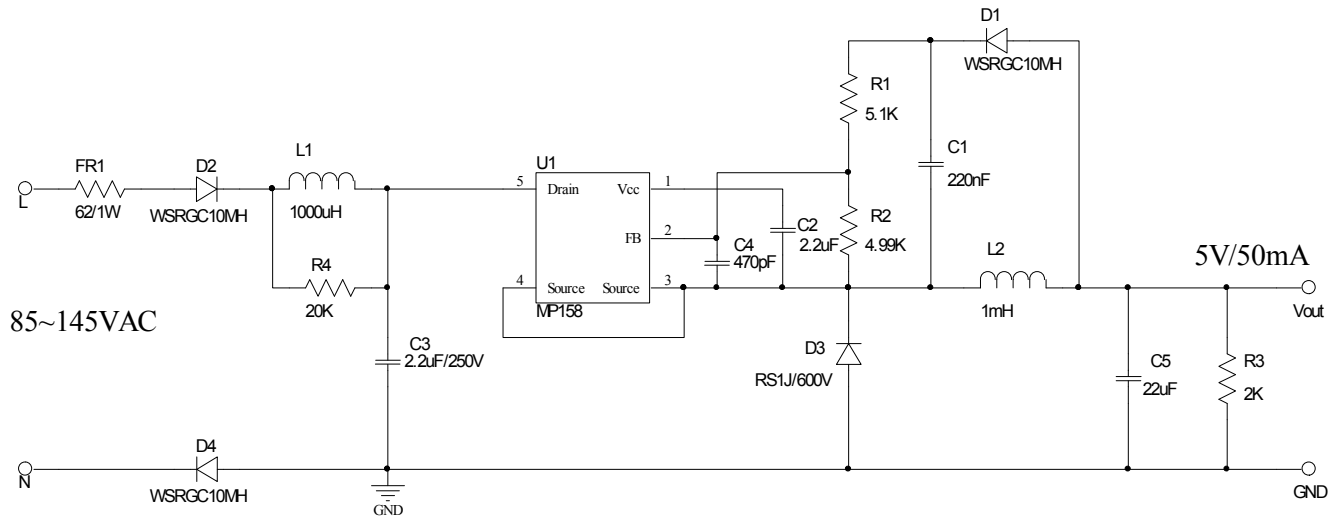

Figure 1—Schematic

PCB LAYOUT (SINGLE-SIDED)

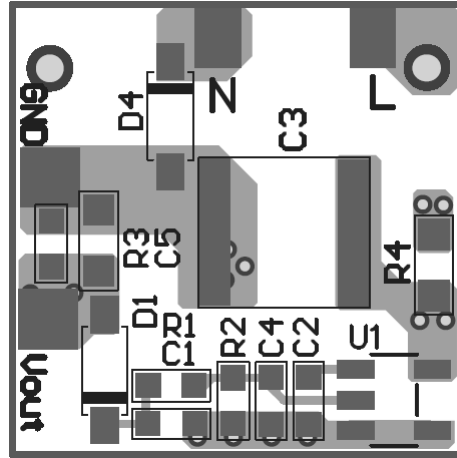

Figure 2—Top Layer

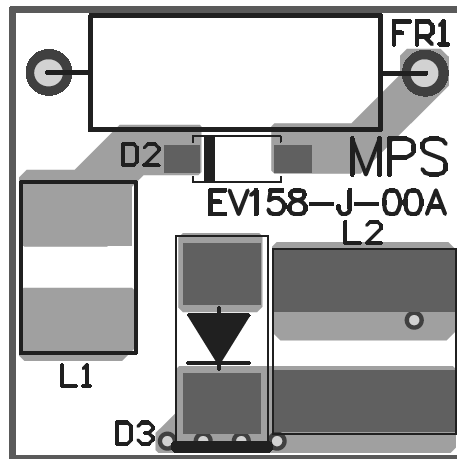

Figure 3—Bottom Layer

BILL OF MATERIALS

Qty	Ref	Value	Description	Package	Manufacturer	Part Number
1	C1	220nF	Ceramic Capacitor;16V;X7R	0603	muRata	GRM188R71C224KA01D
1	C2	2.2µF	Ceramic Capacitor;10V;X7R	0603	muRata	GRM188R71A225KE15D
1	C3	2.2µF	Ceramic Capacitor;250V	2220	TDK	C5750X7T2E225M
1	C4	470pF	Ceramic Capacitor;50V;X7R	0603	muRata	GRM188R71H471KA01D
1	C5	22µF	Ceramic Capacitor;16V;X5R	0805	muRata	GRM21BR61C226ME44L
3	D1, D2, D4	SRGC10MH	Diode;1000V;1A	1206	ZOWIE	SRGC10MH
1	D3	RS1J	Diode;600V;1A	SMA	Diodes	RS1J
1	FR1	62/1W	Fuse Resistor;5%;1W	DIP	Yageo	FKN1WSJT-52-62R
1	L1	1000µH	Inductor;1000µH;30 Ohm;70mA	1812	Wurth	744045102
1	L2	1mH	Inductor; 3.4 Ohm; 240mA	SMD	Coilcraft	LPS6235_105MR
1	R1	5.1k	Film Resistor;1%	0603	Yageo	RC0603FR-075K1L
1	R2	4.99k	Film Resistor;1%	0603	Yageo	RC0603FR-074K99L
1	R3	2k	Film Resistor;5%	0603	Yageo	RC0603JR-072KL
1	R4	20k	Film Resistor;5%	0805	Yageo	RC0805JR-0720KL
1	U1	MP158	Primary side regulator	TSOT23-5	MPS	MP158GJ

CIRCUIT DESCRIPTION

The EV158-J-00A is configured in a buck topology to demonstrate the performance of MP158. MP158 is a primary side controller which provides accurate constant voltage. It simplifies the schematic and minimizes the BOM cost.

FR1 is used to protect circuit from component failure or some excessive short events; also it can restrain the inrush current.

C3, L1 compose LC filter to meet the conducted EMI standard EN55022. C3 is also used for energy storage and protecting against line surge.

With FR1 and C3 used, EV158-J-00A meets calss1 (0.5kV) IEC61000-4-5 surge immunity standard.

C1 is the sample-hold capacitor used for reflecting output voltage. R1 and R2 are resistor divider for detecting output voltage by sampling voltage on C1.

D3 is the freewheeling diode. For universal voltage applications, use a diode with a 600V reverse block voltage. Fast recovery diode or ultra fast diode is recommended for better efficiency and reliable operation.

C5 is the output capacitors for 5V output. R3 is dummy load to lower the output voltage of 5V rail at no load condition.