



## 0.25 LSB GaAs MMIC 6-BIT DIGITAL ATTENUATOR, DC - 6 GHz

### Typical Applications

The HMC792ALP4E is ideal for:

- Cellular/3G Infrastructure
- WiBro / WiMAX / 4G
- Microwave Radio & VSAT
- Test Equipment and Sensors
- IF & RF Applications

### Features

- 0.25 dB LSB Steps to 15.75 dB
- Power-Up State Selection
- High Input IP3: +53 dBm
- Low Insertion Loss: 1.8 dB @ 2.0 GHz
- TTL/CMOS Compatible, Serial, Parallel or Latched Parallel Control
- ±0.1 dB Typical Step Error
- Single +3V or +5V Supply
- 24 Lead 4x4mm SMT Package: 16mm<sup>2</sup>

### Functional Diagram

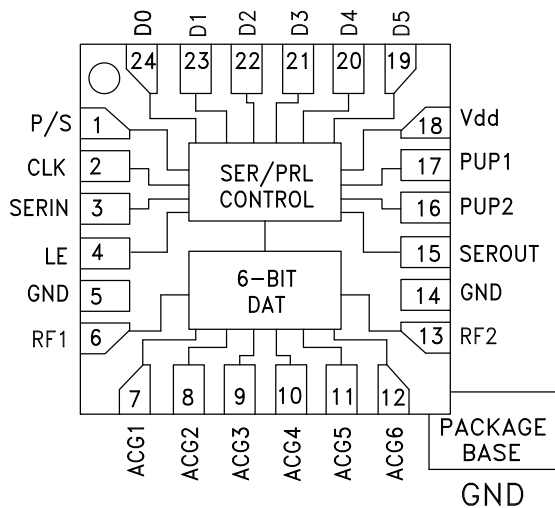

### General Description

The HMC792ALP4E is a broadband 6-bit GaAs IC Digital Attenuator in a low cost leadless SMT package. This versatile digital attenuator incorporates off-chip AC ground capacitors for near DC operation, making it suitable for a wide variety of RF and IF applications. The dual mode control interface is CMOS/TTL compatible, and accepts either a three wire serial input or a 6 bit parallel word. The HMC792ALP4E also features a user selectable power up state and a serial output port for cascading other Hittite serial controlled components. The HMC792ALP4E is housed in a RoHS compliant 4x4 mm QFN leadless package, and requires no external matching components.

### Electrical Specifications, $T_A = +25^\circ C$ , $V_{ctl} = 0/+V_{dd}$

| Parameter  | Frequency (GHz) | Min.                                | Typ.  | Max. | Min.                  | Typ.  | Max. | Units                |    |
|--|-----------------|-------------------------------------|-------|------|-----------------------|-------|------|----------------------|----|
|  |                 | V <sub>dd</sub> = +3V               |       |      | V <sub>dd</sub> = +5V |       |      |                      |    |
| Insertion Loss   | DC - 3.0 GHz    |                                     | 1.8   | 2.4  |                       | 1.8   | 2.4  | dB                   |    |
|  | 3.0 - 6.0 GHz   |                                     | 2.3   | 4.0  |                       | 2.3   | 4.0  | dB                   |    |
| Attenuation Range  | DC - 6.0 GHz    |                                     | 15.75 |      |                       | 15.75 |      | dB                   |    |
| Return Loss (RF1, RF2, All Atten. States)                                      | DC - 6.0 GHz    |                                     | 18    |      |                       | 18    |      | dB                   |    |
| Attenuation Accuracy: (Referenced to Insertion Loss)<br>All Attenuation States | DC - 6.0 GHz    | ± (0.2 + 3% of Atten. Setting) Max. |       |      |                       |       |      | dB<br>dB<br>dB<br>dB |    |
| Input Power for 0.1 dB Compression   | 0.05 - 0.15 GHz |                                     | 22    |      |                       | 22    |      | dBm                  |    |
|  | 0.15 - 6.0 GHz  |                                     | 27    |      |                       | 31    |      | dBm                  |    |
| Input Third Order Intercept Point<br>(Two-Tone Input Power= 10 dBm Each Tone)  | DC - 6.0 GHz    |                                     | 53    |      |                       | 53    |      | dBm                  |    |
| Switching Characteristics  | DC - 6.0 GHz    |                                     |       |      |                       |       |      |                      |    |
|  |                 | tRISE, tFALL (10/90% RF)            |       | 110  |                       |       | 110  |                      | ns |
|  |                 | tON, tOFF (50% CTL to 10/90% RF)    |       | 150  |                       |       | 150  |                      | ns |
| Supply Current   | DC - 6.0 GHz    |                                     | 2.1   |      |                       | 2.2   |      | mA                   |    |

Information furnished by Analog Devices is believed to be accurate and reliable. However, no responsibility is assumed by Analog Devices for its use, nor for any infringements of patents or other rights of third parties that may result from its use. Specifications subject to change without notice. No license is granted by implication or otherwise under any patent or patent rights of Analog Devices. Trademarks and registered trademarks are the property of their respective owners.

For price, delivery, and to place orders: Analog Devices, Inc., One Technology Way, P.O. Box 9106, Norwood, MA 02062-9106 Phone: 781-329-4700 • Order online at [www.analog.com](http://www.analog.com) Application Support: Phone: 1-800-ANALOG-D



**0.25 LSB GaAs MMIC 6-BIT  
DIGITAL ATTENUATOR, DC - 6 GHz**

**Insertion Loss vs. Temperature<sup>[1]</sup>**

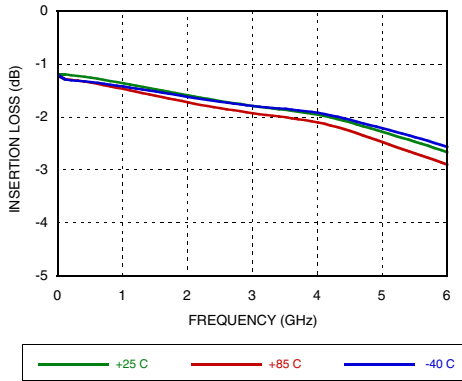

**Normalized Attenuation<sup>[1]</sup>**  
(Only Major States are Shown)

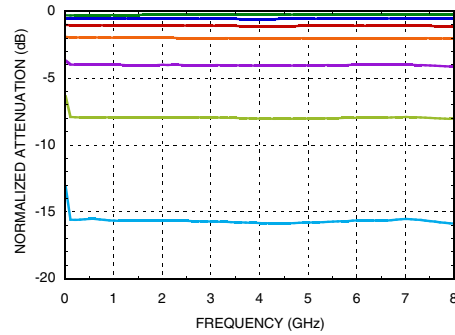

**Input Return Loss<sup>[1]</sup>**  
(Only Major States are Shown)

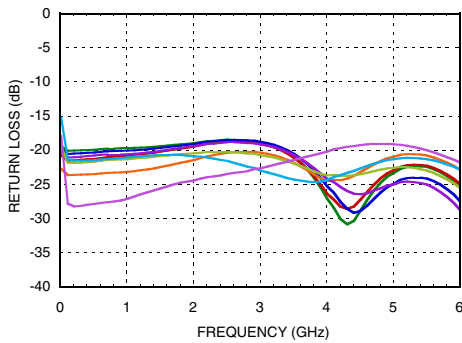

**Output Return Loss<sup>[1]</sup>**  
(Only Major States are Shown)

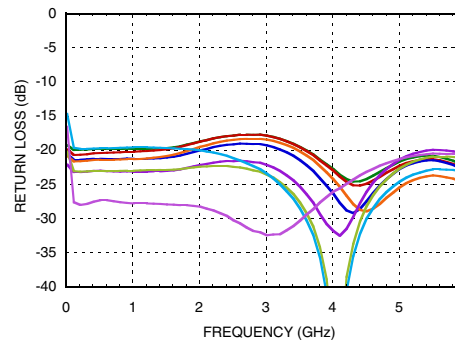

**Bit Error vs. Attenuation State**

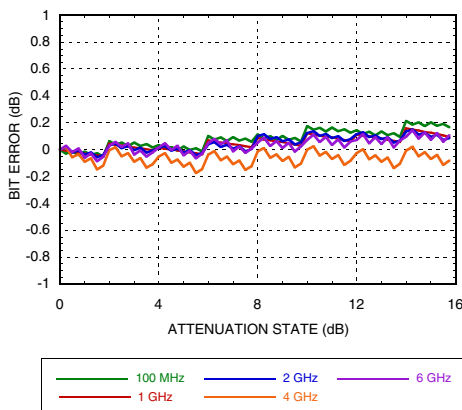

**Bit Error vs. Attenuation State<sup>[2]</sup>**

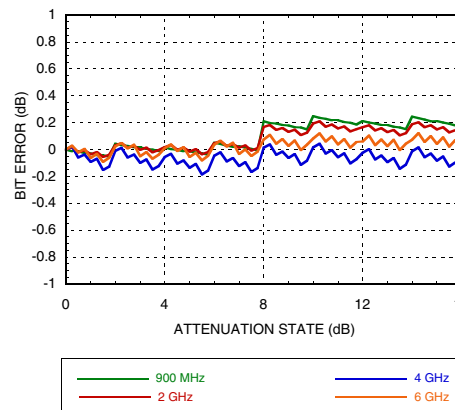

[1] Data taken with broadband DC blocks on RF ports, Vdd = 5V

[2] Data taken with ACG capacitors, C4, C5 & C6 removed. See application circuit and note.



**0.25 LSB GaAs MMIC 6-BIT  
DIGITAL ATTENUATOR, DC - 6 GHz**

**Bit Error vs. Frequency**  
(Only Major States are Shown)

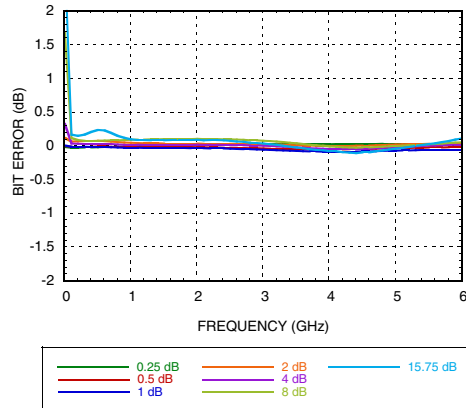

**Bit Error vs. Frequency<sup>[2]</sup>**  
(Only Major States are Shown)

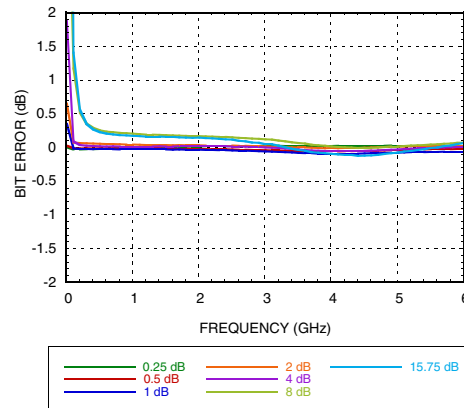

**Worst Case Step Error Between Successive  
Attenuation States (Only Major States are Shown)**

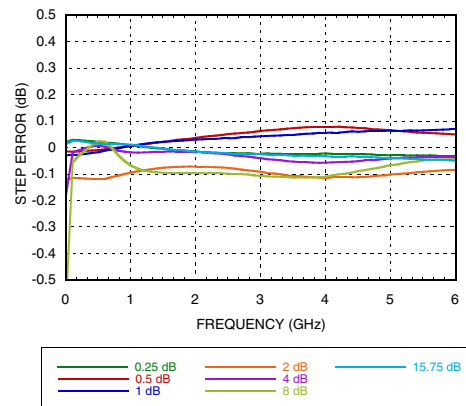

**Input IP3 at 25 °C (Major Bit States at Each  
Frequency is Shown)**

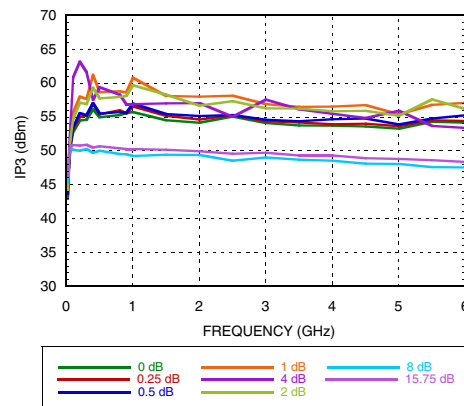

**Input IP3 at -40 °C (Major Bit States at Each  
Frequency is Shown)**

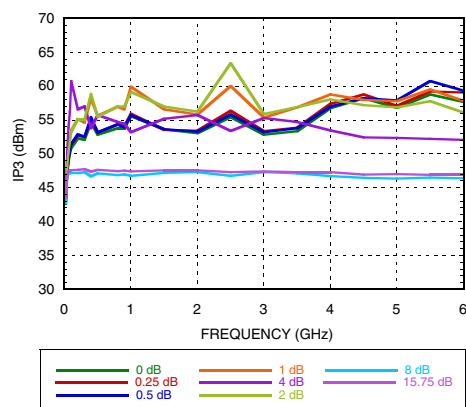

**Input IP3 at 85 °C (Major Bit States at Each  
Frequency is Shown)**

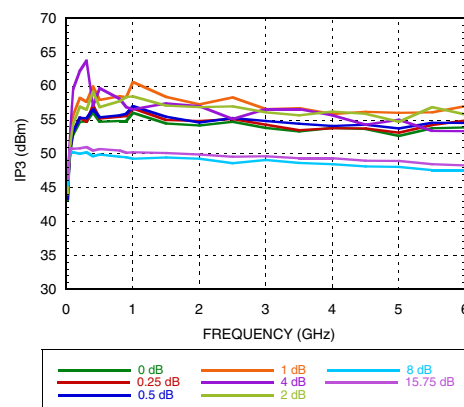

[2] Data taken with ACG capacitors, C4, C5 & C6 removed. See application circuit and note.



## 0.25 LSB GaAs MMIC 6-BIT DIGITAL ATTENUATOR, DC - 6 GHz

**Input Power for 0.1dB Compression @ Vdd = 3V** (Detail of Low Frequency Roll-Off)

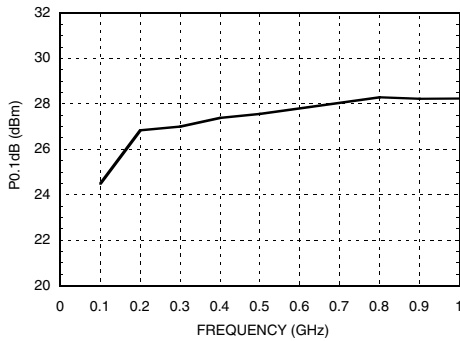

**Input Power for 0.1dB Compression @ Vdd = 5V** (Detail of Low Frequency Roll-Off)

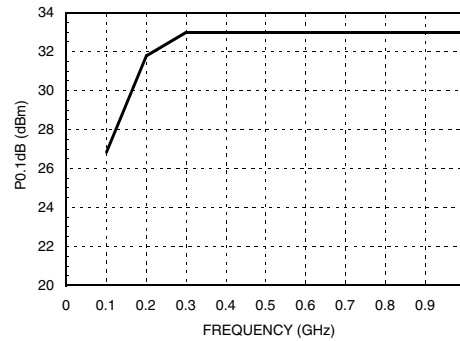

### Serial Control Interface

The HMC792ALP4E contains a 3-wire SPI compatible digital interface (SERIN, CLK, LE). The serial control interface is activated when P/S is kept high. The 6-bit serial word must be loaded MSB first. The positive-edge sensitive CLK and LE requires clean transitions. If mechanical switches are used, sufficient debouncing should be provided. When LE is high, 6-bit data in the serial input register is transferred to the attenuator. When LE is high CLK is masked to prevent data transition during output loading.

When P/S is low, 3-wire SPI interface inputs (SERIN, CLK, LE) are disabled and the input register is loaded with parallel digital inputs (D0-D5). When LE is high, 6-bit parallel data changes the state of the part per truth table.

For all modes of operations, the attenuation state will stay constant while LE is kept low.

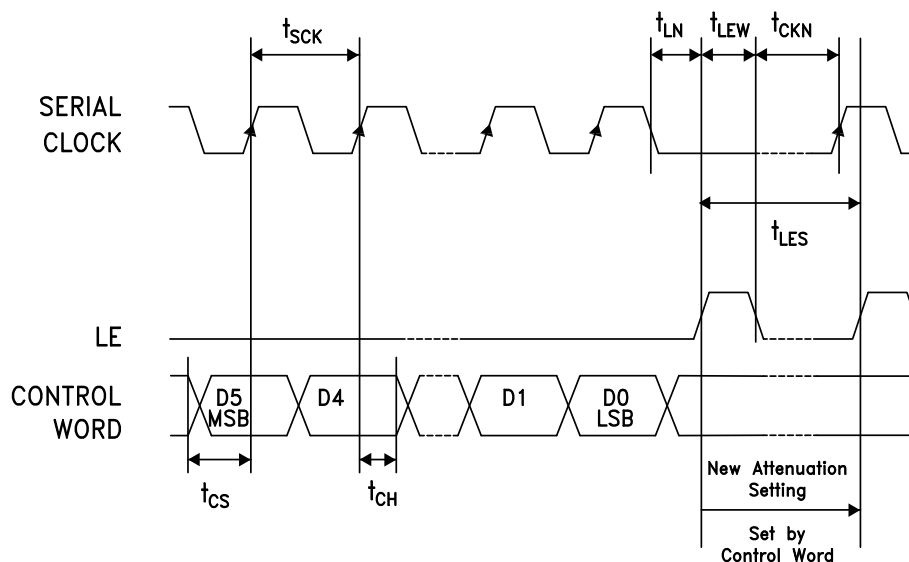



## 0.25 LSB GaAs MMIC 6-BIT DIGITAL ATTENUATOR, DC - 6 GHz

### Timing Diagram (Latched Parallel Mode)

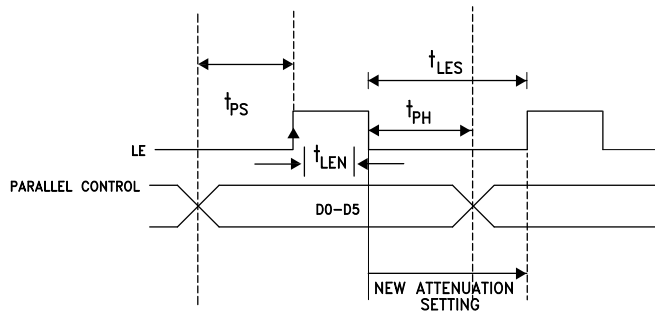

| Parameter                                 | Typ.   |
|---|--------|
| Min. serial period, $t_{SCK}$             | 100 ns |
| Control set-up time, $t_{CS}$             | 20 ns  |
| Control hold-time, $t_{CH}$               | 20 ns  |
| LE setup-time, $t_{LN}$                   | 10 ns  |
| Min. LE pulse width, $t_{LEW}$            | 10 ns  |
| Min LE pulse spacing, $t_{LES}$           | 630 ns |
| Serial clock hold-time from LE, $t_{CKN}$ | 10 ns  |
| Hold Time, $t_{PH}$                       | 0 ns   |
| Latch Enable Minimum Width, $t_{LEN}$     | 10 ns  |
| Setup Time, $t_{PS}$                      | 2 ns   |

### Parallel Mode (Direct Parallel Mode & Latched Parallel Mode)

**Note:** The parallel mode is enabled when P/S is set to low.

**Direct Parallel Mode** - The attenuation state is changed by the control voltage inputs D0-D5 directly. The LE (Latch Enable) must be at a logic high at all times to control the attenuator in this manner.

**Latched Parallel Mode** - The attenuation state is selected using the control voltage inputs D0-D5 and set while the LE is in the Low state. The attenuator will not change state while LE is Low. Once all Control Voltage Inputs are at the desired states the LE is pulsed. See timing diagram above for reference.

### Power-Up States

If LE is set to logic LOW at power-up, the logic state of PUP1 and PUP2 determines the power-up state of the part per PUP truth table. If the LE is set to logic HIGH at power-up, the logic state of D0-D5 determines the power-up state of the part per truth table. The attenuator latches in the desired power-up state approximately 200 ms after power-up.

### Power-On Sequence

The ideal power-up sequence is: GND, Vdd, digital inputs, RF inputs. The relative order of the digital inputs are not important as long as they are powered after Vdd / GND

### Control Voltage Table

| State | Vdd = +3V              | Vdd = +5V              |
|-------|------------------------|------------------------|
| Low   | 0 to 0.5V @ <1 $\mu$ A | 0 to 0.8V @ <1 $\mu$ A |
| High  | 2 to 3V @ <1 $\mu$ A   | 2 to 5V @ <1 $\mu$ A   |

### PUP Truth Table

| LE | PUP1 | PUP2 | Relative Attenuation |
|----|------|------|----------------------|
| 0  | 0    | 0    | -15.75               |
| 0  | 1    | 0    | -12                  |
| 0  | 0    | 1    | -8                   |
| 0  | 1    | 1    | Insertion Loss       |
| 1  | X    | X    | 0 to -15.75 dB       |

**Note:** The logic state of D0 - D5 determines the power-up state per truth table shown below when LE is high at power-up.

### Truth Table

| Control Voltage Input |      |      |      |      |      | Reference Insertion Loss |
|-----------------------|------|------|------|------|------|--------------------------|
| D5                    | D4   | D3   | D2   | D1   | D0   |                          |
| High                  | High | High | High | High | High | 0 dB                     |
| High                  | High | High | High | High | Low  | -0.25 dB                 |
| High                  | High | High | High | Low  | High | -0.5 dB                  |
| High                  | High | High | Low  | High | High | -1 dB                    |
| High                  | High | Low  | High | High | High | -2 dB                    |
| High                  | Low  | High | High | High | High | -4 dB                    |
| Low                   | High | High | High | High | High | -8 dB                    |
| Low                   | Low  | Low  | Low  | Low  | Low  | -15.75 dB                |

Any combination of the above states will provide an attenuation equal to the sum of the bits selected.



## 0.25 LSB GaAs MMIC 6-BIT DIGITAL ATTENUATOR, DC - 6 GHz

### Absolute Maximum Ratings

|  |                  |
|--|------------------|
| RF Input Power (DC - 6 GHz)  | +29 dBm          |
| Digital Inputs (D0 to D5, P/S, CLK, SERIN, LE, PUP1, PUP2)                     | -0.5 to Vdd +0.5 |
| Bias Voltage (Vdd)   | 5.6V             |
| Channel Temperature  | 150 °C           |
| Continuous P <sub>diss</sub> (T = 85 °C)<br>(derate 9.9 mW/°C above 85 °C) [1] | 0.715 W          |
| Thermal Resistance<br>(Channel to package bottom)                              | 90.9 °C/W        |
| Storage Temperature  | -65 to +150 °C   |
| Operating Temperature  | -40 to +85 °C    |



ELECTROSTATIC SENSITIVE DEVICE  
OBSERVE HANDLING PRECAUTIONS

### Outline Drawing

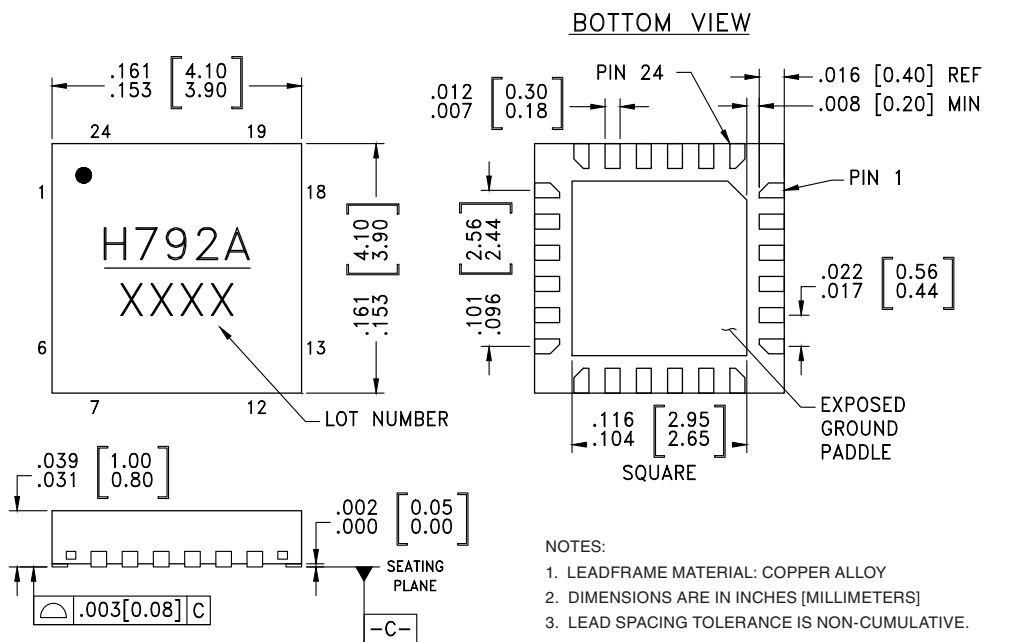

NOTES:

- LEADFRAME MATERIAL: COPPER ALLOY
- DIMENSIONS ARE IN INCHES [MILLIMETERS]
- LEAD SPACING TOLERANCE IS NON-CUMULATIVE.
- PAD BURR LENGTH SHALL BE 0.15mm MAXIMUM.  
PAD BURR HEIGHT SHALL BE 0.05mm MAXIMUM.
- PACKAGE WARP SHALL NOT EXCEED 0.05mm.
- ALL GROUND LEADS AND GROUND PADDLE MUST BE SOLDERED TO PCB RF GROUND.
- REFER TO HITTITE APPLICATION NOTE FOR SUGGESTED LAND PATTERN.



### Package Information

| Part Number | Package Body Material                              | Lead Finish   | MSL Rating | Package Marking [1] |
|-------------|--|---------------|------------|---------------------|
| HMC792ALP4E | RoHS-compliant Low Stress Injection Molded Plastic | 100% matte Sn | MSL1 [2]   | H792A<br>XXXX       |

[1] 4-Digit lot number XXXX

[2] Max peak reflow temperature of 260 °C

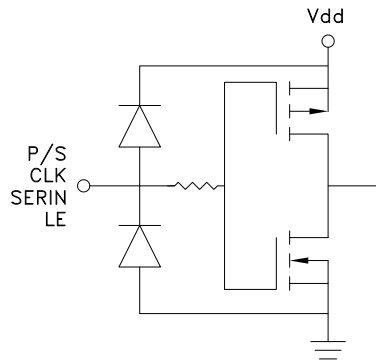

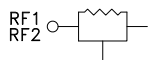
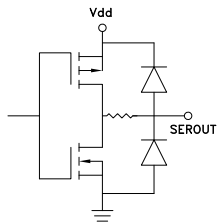
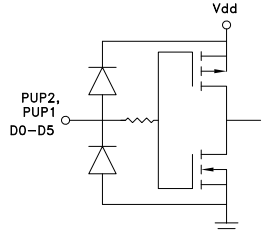
**0.25 LSB GaAs MMIC 6-BIT  
DIGITAL ATTENUATOR, DC - 6 GHz**
**Pin Descriptions**

| Pin Number | Function               | Description  | Interface Schematic   |
|------------|------------------------|--|---|
| 1          | P/S                    | See truth table, control voltage table and timing diagram.   |    |
| 2          | CLK                    |  |   |
| 3          | SERIN                  |  |   |
| 4          | LE                     |  |   |
| 5, 14      | GND                    | These pins and package bottom must be connected to RF/DC ground.   |    |
| 6, 13      | RF1, RF2               | These pins are DC coupled and matched to 50 Ohms. Blocking capacitors are required. Select value based on lowest frequency of operation. |    |
| 7 - 12     | ACG1 - ACG6            | External capacitors to ground is required. Select value for lowest frequency of operation. Place capacitor as close to pins as possible. |   |
| 15         | SEROUT                 | Serial input data delayed by 6 clock cycles.   |  |
| 16, 17     | PUP2, PUP1             | See truth table, control voltage table and timing diagram.   |  |
| 19 - 24    | D5, D4, D3, D2, D1, D0 |  |   |
| 18         | Vdd                    | Supply voltage   |   |

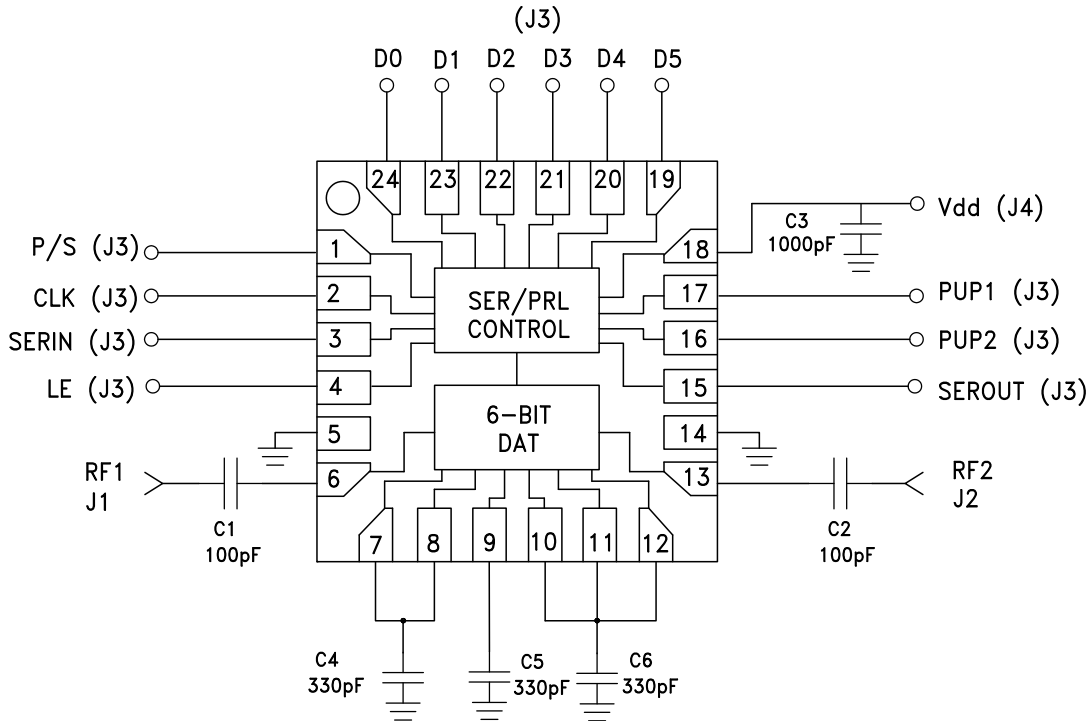

**0.25 LSB GaAs MMIC 6-BIT  
DIGITAL ATTENUATOR, DC - 6 GHz**

**Application Circuit**



For frequencies less than 700 MHz, the use of ACG capacitors C4, C5 and C6 is recommended. For frequencies greater than 700 MHz, the HMC792ALP4E has similar performance with and without the ACG capacitors.





**0.25 LSB GaAs MMIC 6-BIT  
DIGITAL ATTENUATOR, DC - 6 GHz**

**Evaluation PCB**

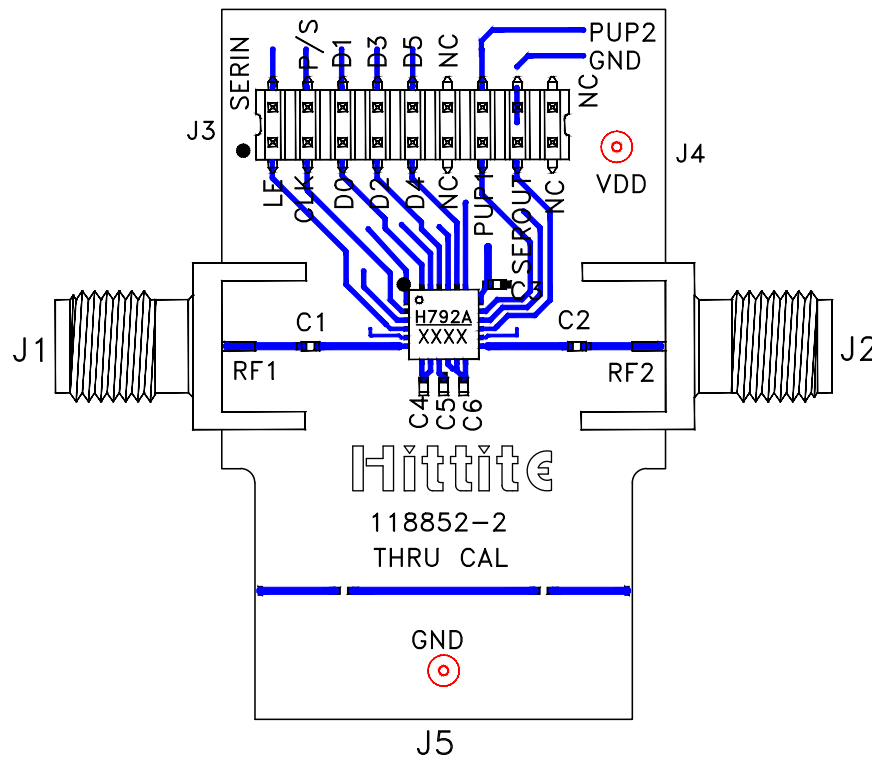

**List of Materials for Evaluation PCB EV1HMC792ALP4 [1]**

| Item    | Description                    |
|---------|--------------------------------|
| J1, J2  | PCB Mount SMA Connector        |
| J3      | 18 Pin DC Connector            |
| J4, J5  | DC Pin                         |
| C1, C2  | 100 pF Capacitor, 0402 Pkg.    |
| C3      | 1000 pF Capacitor, 0402 Pkg.   |
| C4 - C6 | 330 pF Capacitor, 0402 Pkg.    |
| U1      | HMC792ALP4E Digital Attenuator |
| PCB [2] | 118852 Evaluation PCB          |

The circuit board used in the final application should use RF circuit design techniques. Signal lines should have 50 Ohm impedance while the package ground leads and exposed paddle should be connected directly to the ground plane similar to that shown. A sufficient number of via holes should be used to connect the top and bottom ground planes. The evaluation circuit board shown is available from Hittite upon request.

[1] Reference this number when ordering complete evaluation PCB

[2] Circuit Board Material: Arlon 25FR or Rogers 4350