

DESCRIPTION

The MP20073 integrates the DDR memory termination regulator with the output voltage (VTT) and a buffered VTTREF whose output is half of VREF.

The VTT-LDO is a 2A sink/source tracking termination regulator. It is specifically designed for low-cost/low-external component count systems, where space is a premium.

The MP20073 maintains a fast transient response only requiring 20uF (2x10uF) of ceramic output capacitance. The MP20073 supports Kelvin sensing functions.

The MP20073 is available in the 8-pin MSOP with Exposed PAD, package and is specified from -40°C to 85°C.

ELECTRICAL SPECIFICATIONS

Parameter	Symbol	Value	Units
Input Bias Voltage	V_{DRV}	3.3	V
Input Voltage	V_{DDQ}	1.3-1.8	V
Reference Input Voltage	V_{REF}	V_{DDR}	V
Output Voltage	V_{TT}	$1/2 V_{DDR}$	V
Output Current	I_{TT}	± 2	A

FEATURES

- VDDQ Voltage Range: 1.3V to 6.0 V
- Up to 2A Integrated Sink/Source Linear Regulator with Accurate VDDQ/2 Divider Reference for DDR Termination
- Requires Only 20uF Ceramic Output Capacitance
- Drive Voltage Range: 3.3V
- 1.3V Input (VDDQ) Helps Reduce Total Power Dissipation
- Integrated Divider Tracks VREF for VTT and VTTREF
- Kelvin Sensing (VTTSEN)
- $\pm 30\text{mV}$ Accuracy for VTT and VTTREF
- Built-In Soft-Start, UVLO and OCL
- Thermal Shutdown

APPLICATIONS

- Notebook DDR2/3 Memory Supply and Termination Voltage in ACPI Compliant
- Active Termination Busses

"MPS" and "The Future of Analog IC Technology", are Trademarks of Monolithic Power Systems, Inc.

EV20073DH-00A EVALUATION BOARD



(L x W x H) 2.5" x 2.5" x 0.5"
(6.5cm x 6.5cm x 1.2cm)

Board Number	MPS IC Number
EV20073DH-00A	MP20073DH

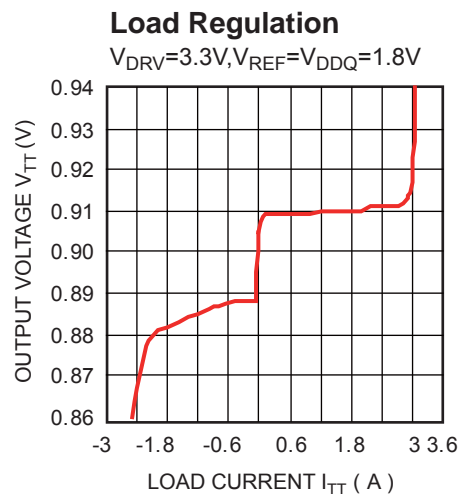

EVALUATION BOARD SCHEMATIC

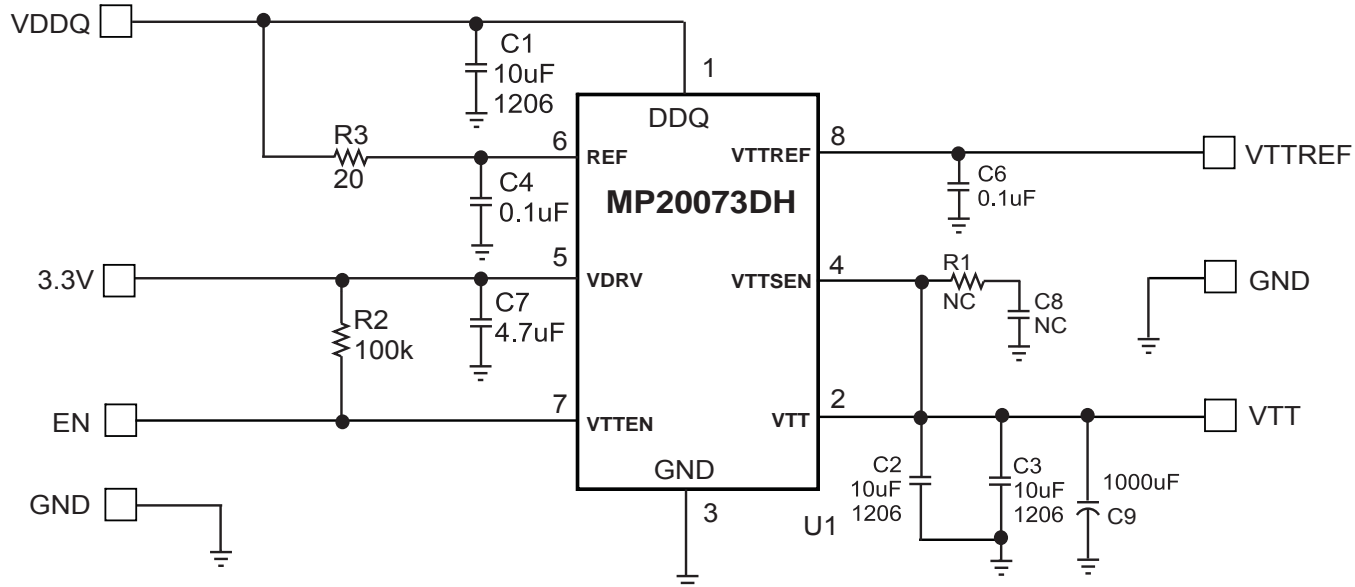

EV20073DH-00A BILL OF MATERIALS

Qty	Ref	Value	Description	Package	Manufacturer	Manufacturer P/N
3	C1, C2, C3	10uF	Ceramic Cap., 16V, X7R	1206	muRata	GRM31CR71C106KAC7L
2	C4, C6	0.1uF	Ceramic Cap., 16V, X7R	0603	muRata	GRM188R71C104KA01D
1	C7	4.7uF	Ceramic Cap., 16V, X7R	0805	muRata	GRM21BR71C475KA73L
1	C8, C9	NS		0603		
1	R1	NS		0603		
1	R2	100KΩ	Film Res., 5%	0603	Yageo	RC0603JR-07100KL
1	R3	0	Film Res., 5%	0603	Yageo	9C06031A0R00JL
1	R4	20	Film Res., 5%	0603	Yageo	9C06031A20R0JLHFT
1	U1		Termination Regulator	MSOP8	MPS	MP20073DH

PRINTED CIRCUIT BOARD LAYOUT

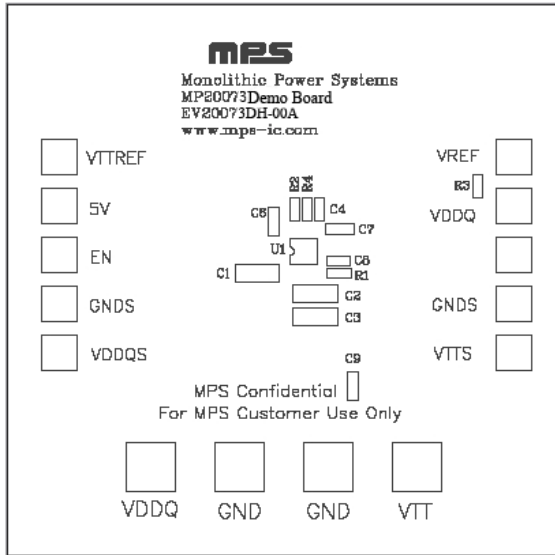

Figure 1—Top Silk Layer

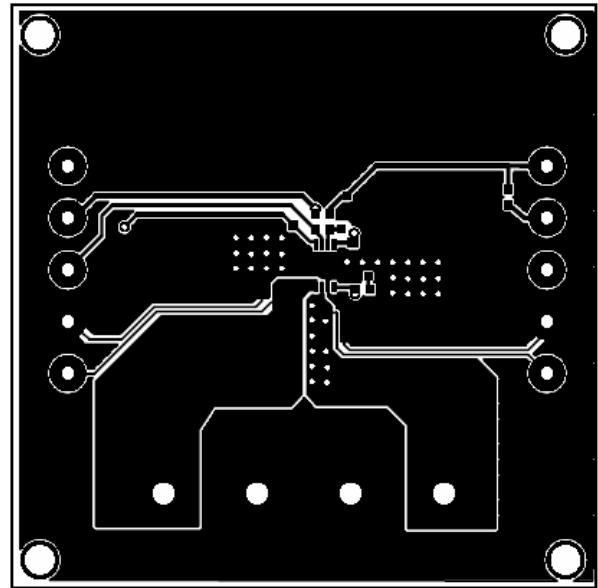

Figure 2—Top Layer

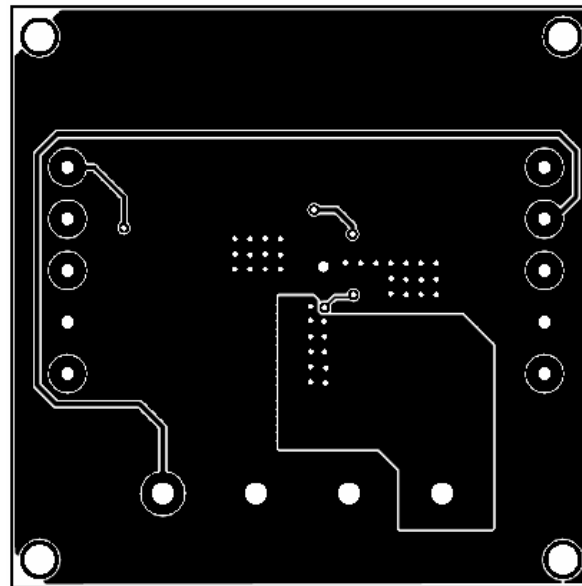

Figure 3—Bottom Layer