



The Future of Analog IC Technology®

EV2690-R-00B

Reference Design for MP2690, All-in-one
2.5A Battery Charger with 2.1A Boost Current

DESCRIPTION

The EV2690-R-00B is the reference design board for MP2690, a highly-integrated, flexible switch-mode battery charge management for a single-cell Li-ion and Li-Polymer battery used in a wide range of applications.

The demo board uses two operating modes—charge mode and boost mode—to allow management of system and battery power based on the state of the input.

When input power is present, the board charges a single-cell battery with a charge current of 2.5A.

In the absence of an input source, the board switches to boost mode through the PB pin to power the SYS pins from the battery with a current of up to 2.1A.

The evaluation board provides 4-LED drivers to achieve the voltage based fuel gauge indication and distinguish charge mode from boost mode.

To guarantee safe operation, the EV2690-R-00B has input-over-voltage protection, battery over-voltage protection, thermal shutdown, battery-temperature monitoring, and a timer to prevent prolonged charging of a dead battery.

ELECTRICAL SPECIFICATION

Parameter	Symbol	Value	Units
Charge Mode			
Input Voltage Range	V_{IN}	4.55 – 6	V
Charge-Full Voltage	V_{BATT_Full}	4.2 / 4.35 / 4.45	V
Charge Current	I_{CHG}	2.5	A
Input Current Limit	I_{IN_LIM}	2.7	A
Boost Mode			
Battery Voltage	V_{BATT}	3-4.45	V
SYS Voltage Regulation	V_{SYS}	5	V
SYS Output Current Limit	I_{SYS}	2.1	A

FEATURES

- 4.55V-to-6V Operating Input Voltage Range
- Power Management Function Integrated Input-Current-Limit and Input Voltage Regulation
- Up to 2.5A Charge Current
- Selectable 4.45V / 4.35V / 4.2V Charge Voltage with 0.5% Accuracy
- Battery Temperature Monitoring
- 4-LED drivers for battery fuel gauge indication
- Timer Back-Up Protection
- Battery-Reverse-Leakage Blocking
- Reverse-Boost-Operation for Powering System
- Up to 94.5% 5V Boost Mode Efficiency @ 3A with BATT=4.2V
- Up to 2.1A Output Current Limit in Boost Mode

APPLICATIONS

- Sub-battery Applications
- Power-bank Applications for Smart-Phone, Tablet and Other Portable Devices

All MPS parts are lead-free, halogen free, and adhere to the RoHS directive. For MPS green status, please visit MPS website under Quality Assurance.

"MPS" and "The Future of Analog IC Technology" are Registered Trademarks of Monolithic Power Systems, Inc.

EV2690-R-00B EVALUATION BOARD

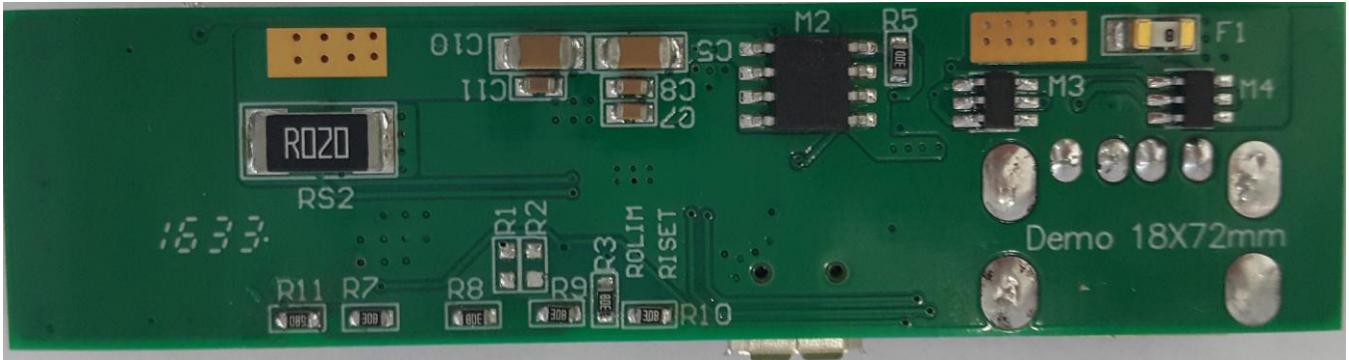
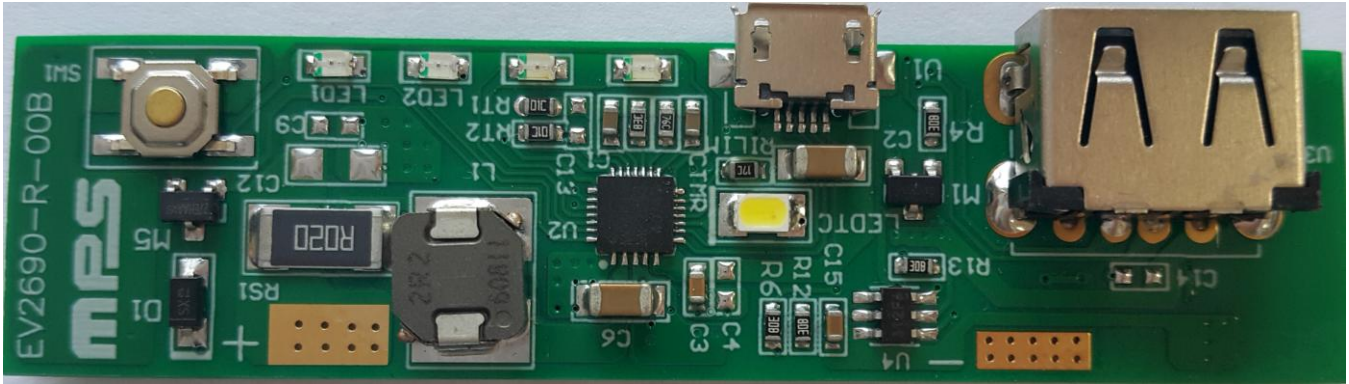

(L x W x H) 2.8" x0.7"x 0.063"
(7.16cm x 1.8cm x 0.16cm)

Board Number	MPS IC Number
EV2690-R-00B	MP2690GR

EVALUATION BOARD SCHEMATIC

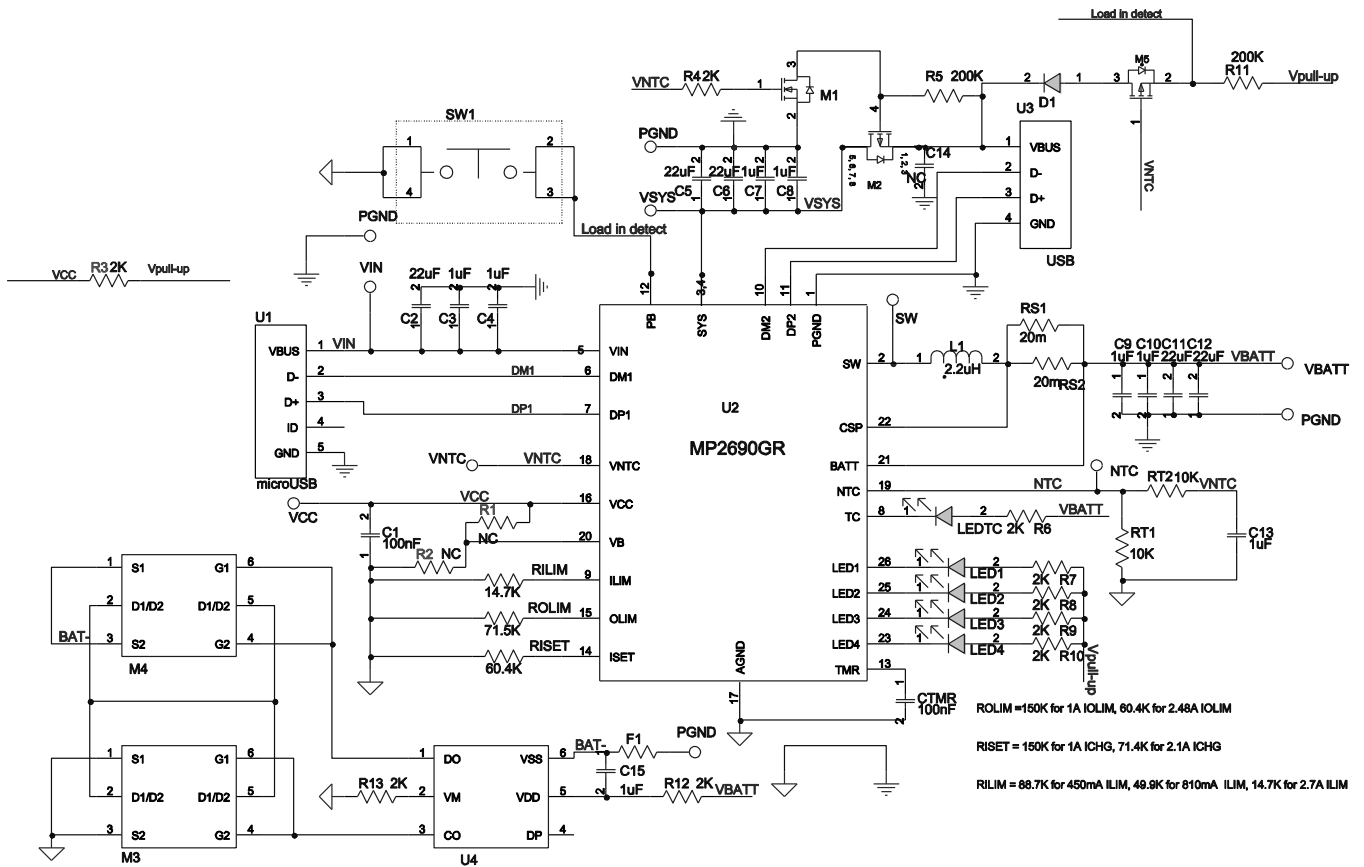

EV2690-R-00B BILL OF MATERIALS

Qty	Ref	Value	Description	Package	Manufacture	Manufacture_PN
1	D1	B130LAW	Schottky;30V;1A	SOD-123		B130LAW-7-F
2	RS1, RS2	20m	Resistor;1%;	2512	Yageo	RL2512FK-070R02L
1	R1SET	60.4k	Film Resistor;1%	0603	Yageo	RC0603FR-0760K4L
1	ROLIMIT	71.5k	Film Resistor;1%	0603	Yageo	RC0603FR-0771K5L
2	R1, R2	NC				
1	RILIM	14.7k	Film Resistor;1%	0603	Yageo	RC0603FR-0714K7L
2	RT1, RT2	10k	Film Resistor;1%;	0603	Yageo	RC0603FR-0710KL
5	C4, C9, C12, C13, C14	NC				
1	C15	1 μ F	Ceramic Capacitor; 16V;X7R;0603;	0603	muRata	GRM188R71C105KA12D
5	C2, C5, C6, C10	22 μ F	Ceramic Capacitor; 25V;X5R;	1206	muRata	GRM31CR61E226KE15
1	R5	200k	Film Resistor;1%	0603	Yageo	RC0603FR-07200KL
1	R11	200k	Film Resistor;1%	0603	Yageo	RC0603FR-07200KL
8	R3, R4, R6, R7, R8, R9, R10, R12, R13	2k	Film Resistor;1%	0603	LIZ	CR0603JA0202G
6	C3, C7, C8, C11	1 μ F	Ceramic Capacitor; 25V;X7R	0603	TDK	C1608X7R1E105K
2	C1, CTMR	100nF	Ceramic Capacitor; 16V;X7R;0603	0603	TDK	C1608X7R1C104K
1	LEDTC	3020White	LED; White, 3.2-3.4V/30mA,	3020		
4	LED1, LED2, LED3, LED4	BL-HGB35A-TRB	LED; Green;	0805	BRIGHT LED	BL-HGB35A-TRB
1	M2	AM4825P-T1	P-Channel Mosfet; -30V;-9.3;19;25	SO-8	Analog Power	AM4825-T1-PF
1	M1	AM2336N	N-Channel Mosfet;30V;32;6	SOT-23	Analog Power	AM2336N
1	M5	AM2305PE-T1	P-Channel Mosfet; -20V,-4.5A,43,12	SOT-23	Analog Power	AM2305PE-T1
1	L1	2.2 μ H	Inductor;2.2uH; 0.173m;8.2A	SMD	TDK	SPM6530T-2R2M
1	U1	629105136821	629105136821(USB)		Wurth	629105136821
1	U2	MP2690GR	IC	QFN26 4*4	MPS	
1	U3	USB'				
1	SW1	Push Switching button	Button; SM 4x10mm;1.5mm Height			
2	M3, M4	8205A	Dual N-Channel MOSFET (20V, 6A)	TSSOP_8L		
1	U4	FS312F-P	Battery Protection	SOT-23-6		
1	F1	458008	63V/8A Fuse	1206	Little fuse	458008.DR

PRINTED CIRCUIT BOARD LAYOUT

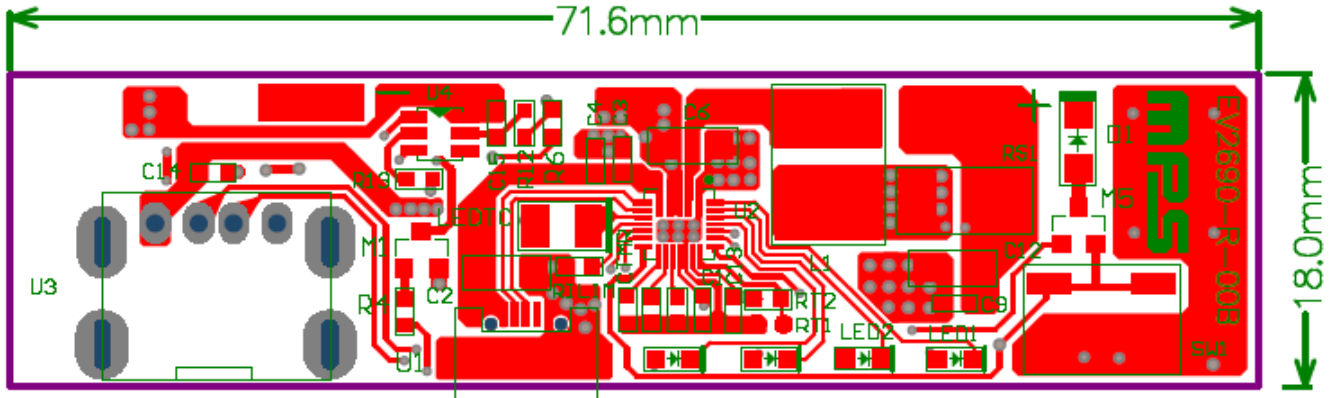

Figure 1: Top Layer

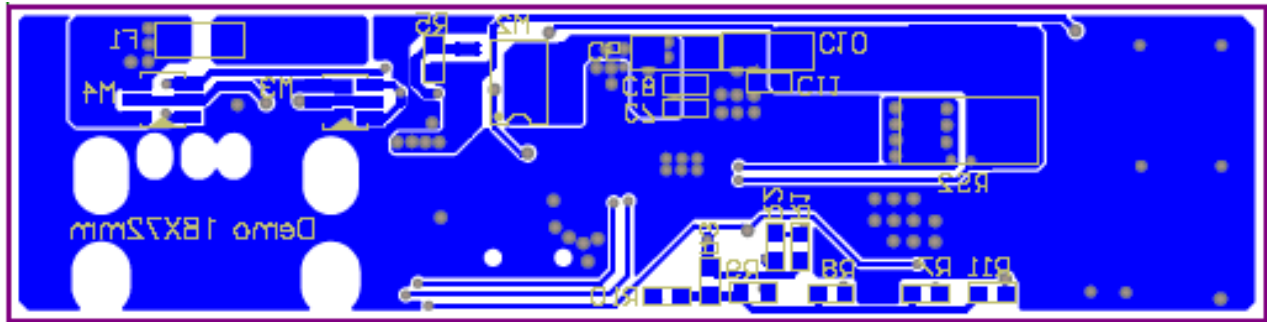

Figure 2: Bottom Layer

QUICK START GUIDE

This board is reference design for MP2690, a stand-alone switch-mode battery charge management and system power path management device with integrated reverse directional boost from BATT to SYS. The board's layout accommodates most commonly-used capacitors. The default function of this board is preset at charge mode, and the charge full voltage is preset to 4.2V for a 1-cell Li-Ion battery.

Charge Mode Setting

1. Input Current Limit

An input current limit can be set slightly below the input source's maximum current rating. When the input current hits this limit, the charge current will decrease to keep the input current constant at the limit value to initially power the system. R_{ILIM} —the resistor connected to the ILIM pin—programs this limit. To set the input current limit at 2.7A, use an R_{ILIM} of 14.7k Ω .

$$I_{ILIM}(A) = \frac{40(k\Omega)}{R_{ILIM}(k\Omega)} \quad (1)$$

2. Charge-Full Voltage

The charge-full voltage on this board is setting at 4.2V as default by keep R1 and R2 float, and the setting can be modified according the following table.

R1	R2	Charge-Full Voltage (V)
Float	Float	4.2
Float	0 Ω	4.35
0 Ω	Float	4.45

3. Charge Current

The charge current can be programmed via both RS1 and R_{ISET} . With given RS1=10m Ω , determine the charge current using the following formula:

$$I_{CHG}(A) = \frac{1500}{R_{ISET}(k\Omega) \times RS1(m\Omega)} \quad (2)$$

For 2.5A charge current, the given R_{ISET} is 60.4k Ω .

Boost Mode

1. System-Output-Current Limit

Set the system-output-current limit in boost mode for the EV2690 to operate like a standard adapter. Set the output current limit as per the following equation:

$$I_{OLIM}(A) = \frac{1500}{R_{OLIM}(k\Omega) \times RS1(m\Omega)} \quad (3)$$

For 2.1A output current limit, the given R_{OLIM} is 71.5k Ω .

For the other detailed description on the operation of the MP2690, please refer to the datasheet.

EQUIPMENT REQUIREMENT

Evaluation requires the following equipments:

1. For the charge input, USB cable with an adaptor or any USB port with load capability can be directly used for the reference design board. In case some operation state can not be tested, external wire can be added to connect a power source with 6V/3A capability.
2. Battery simulator or a single-cell battery pack. The battery simulator's output rating should exceed 4.5V/7.0A. When using a real battery pack, please observe all precautions on the battery manufacturer's data sheet first and ensure the charger's setting doesn't exceed the battery's absolute maximum specifications.
3. E-load or real smart phone. The E-load capability should exceed 5V/2.1A.
4. An oscilloscope. A single voltage probe and a single current probe.
5. Multi-meter.

Charge Function

- 1 Attach the positive and negative ends of the battery to the "+" and "-" terminals, respectively. If it's a battery simulator, please preset the voltage to 3.8V (typical value) first.
- 2 Present the USB cable and adaptor or any USB port with load capability.

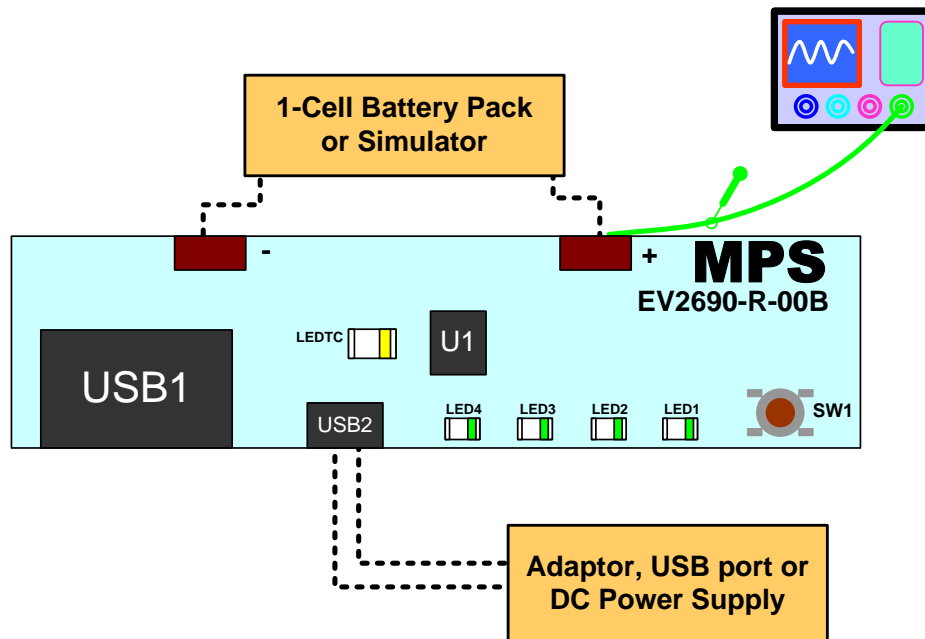

Figure 3: Setup for Charge Mode

- 3 Connect the adaptor or USB port to the demo board through USB2, the charge starts. Use the oscilloscope to verify that the 2.5A charge current is being delivered to the battery, The charge current could be a different value under following conditions:
 - a. The charge current could be limited by input current limit.

The IC features the input source detection to decide the input current limit according to the input source (USB or adaptor). The IC sets the input current limit as following table once the DP1/DM1 detection is done.

DP1/DM 1 Detection	I_{IN_LMT}
Floating	500mA
SDP	500mA
CDP or DCP	Set through R_{ILIM}

- b. The charge current could be limited by the input voltage regulation.

Once the input voltage approaches the input voltage regulation threshold preset at 4.65V internally, charge current is reduced to allow priority of system power and maintain proper regulation of the input voltage. It happens when the input power source does not have enough capability or the voltage loss on USB cable is too big.

- 4 In case some operation state can not be tested, external wire can be added to connect a power source. Short DP1 and DM1 to set the DP1/DM1 detection as SDP, then the input current limit is 500mA.
- 5 Connect USB1 to the E-load or real smart phone, most functions at charge mode can be tested.

- a. Input Current Limit

When the DC power supply has bigger current capability than the input current limit, increase the load current of E-load, when the input current hits this limit, the charge current decreases to keep the input current constant at the limit value.

- b. Input Voltage Regulation

When the DC power supply has smaller current capability than the input current limit, increase the load current of E-load, the input power source may be insufficient to support both the charge current and system load current then the input voltage drops. Once the voltage drops to the V_{IN_REG} , the charge current reduces to allow priority of system power and maintain the input voltage avoid dropping further.

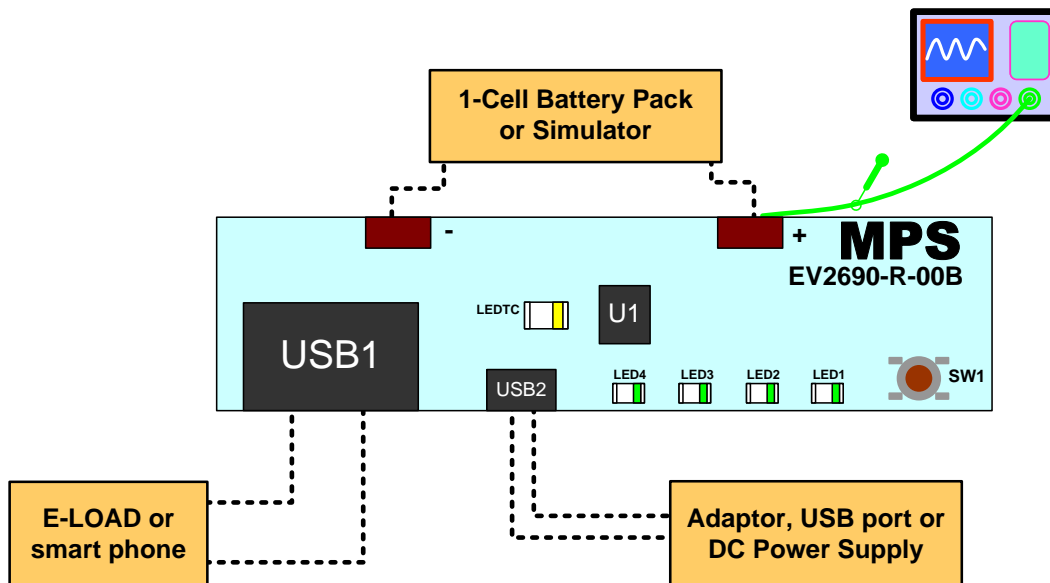

Figure 4: Setup for Charge Mode with System Load