



EV2733-QC-00A

Wide-Input, 4.5A, I²C-Controlled SW Charger with NVDC Power Path Management and USB OTG Evaluation Board

DESCRIPTION

The EV2733-QC-00A is an evaluation board designed to demonstrate the capabilities of the MP2733. The MP2733 is a wide-input, 4.5A, highly integrated switch-mode battery charger IC for single-cell Li-ion or Li-polymer batteries. This device supports narrow voltage DC (NVDC) architecture with power path management. It is well-suited for portable applications, such as tablets, mobile internet devices, and smartphones.

The device's low impedance power path optimizes efficiency, reduces battery charging time, and extends battery life. The I²C serial interface allows the user to flexibly control the device by changing charging and system settings.

The EV2733-QC-00A supports input sources up to 16V, including standard USB host ports and high-voltage wall adapters with fast charge capability. The EV2733-QC-00A supports USB On-the-Go (OTG) operation by supplying 5V with 3.0A.

ELECTRICAL SPECIFICATIONS

Parameter	Symbol	Value	Units
Input voltage	V _{IN}	3.7 to 16	V
Charge full voltage	V _{BATT_REG}	4.2, I ² C-configurable	V
Charge current	I _{CC}	1.84, I ² C-configurable	A
Input voltage regulation	V _{IN_MIN}	4.3, I ² C-configurable	V
Input current limit	I _{IN_LIM}	0.5, I ² C-configurable	A
OTG voltage regulation	V _{IN_DSCHG}	5.0, I ² C-configurable	V
OTG current limit	I _{IN_DSCHG}	0.5, I ² C-configurable	A

FEATURES

- 3.7V to 16V Operating Input Voltage Range
- Up to 22V Sustainable Voltage

- High-Efficiency, 1.35MHz, 4.5A Buck Charger:
 - Configurable D+/D- for Flexible Fast Charge Protocol Support
 - Adjustable Minimum Input Voltage Regulation for MPPT
- USB OTG with 4.8V to 5.5V Adjustable Output, Selectable 1.35MHz Boost Converter, Up to 3.0A Output
- Up to 9A Battery Discharge Current
- Integrated ADC for Monitoring V_{IN}, I_{IN}, V_{BATT}, I_{BATT}, V_{SYS}, and Battery Temperature
- Optional ADC Function for Monitoring V_{BATT} and V_{SYS} under Battery Discharge Mode
- NVDC Power Path Management:
 - Instant Turn-On Works with No Battery or Deeply Discharged Battery
 - Ideal Diode Operation in Battery Supplement Mode
- I²C Port for Flexible System Parameter Setting and Status Reporting
- Full DISC Control to Support Shipping Mode and System Restart
- High Accuracy:
 - ±0.5% Charge Voltage Regulation
 - ±5% Charge Current Regulation
 - ±5% Input Current Regulation
 - ±2% Output Regulation in Boost Mode
- Safety Features:
 - Configurable JEITA for Battery Temp Protection
 - Battery Charging Safety Timer
 - Thermal Regulation and Shutdown
 - Input/System Over-Voltage Protection
- Charging Operation Indicator

APPLICATIONS

- Tablet PCs
- Smartphones
- Mobile Internet Devices

All MPS parts are lead-free, halogen-free, and adhere to the RoHS directive. For MPS green status, please visit the MPS website under Quality Assurance. "MPS", the MPS logo, and "Simple, Easy Solutions" are registered trademarks of Monolithic Power Systems, Inc. or its subsidiaries.

EV2733-QC-00A EVALUATION BOARD



(LxWxH) 6.3cmx6.3cmx1.3cm

Board Number	MPS IC Number
EV2733-QC-00A	MP2733GQC

Efficiency Curve

V_{IN} = 5V, 9V, 12V, or 16V, V_{BATT} = 3.8V,
R_{L_DCR} = 21mΩ

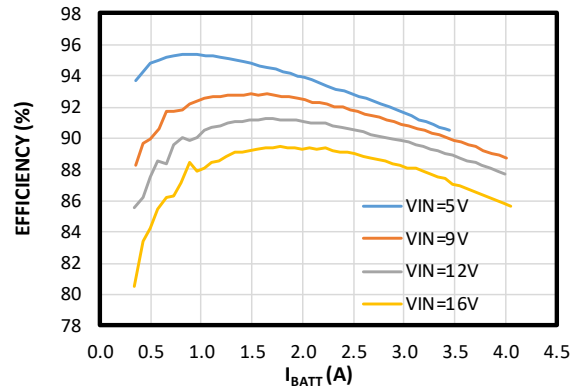

QUICK START GUIDE

The EV2733-QC-00A evaluation board is designed for the MP2733 when the IC is used as a standalone switching charger with integrated USB detection and USB On-the-Go (OTG) functionality. Its layout accommodates most commonly used capacitors. The default function of this board is preset for charger mode, and the charge-full voltage is preset to 4.2V for a single-cell Li-ion battery. Table 1 lists the jumper connections

Table 1: Jumper Connections

Jack	Description	Factory Setting
JP3	OTG pin setting: pull high to enable USB On-the-Go (OTG) mode	Pull low
JP2	CE pin setting: pull low to enable charging mode	Pull low
JP1	NTC pin setting: pull low to set the NTC to a fixed 50% ratio	Pull low
P1	I ² C connector	-

For more details on the MP2733, refer to the MP2733 datasheet.

Evaluation Platform Preparation

1. Use a USB cable and a computer with at least one available USB port. The MP2733 evaluation software must be properly installed.
2. Prepare the USB to I²C communication interface (EVKT-USBI2C-02).



Figure 1: USB to I²C Communication Interface

3. To access the software, double-click on the “MP2733 Evaluation Kit” .exe file to run the MP2733 evaluation software. The software is supported on Windows XP, Windows 7, and later operating systems. The MP2733 evaluation kit .exe file can be downloaded from the MPS website.
4. Configure the test set-up for the MP2733 (see Figure 2).

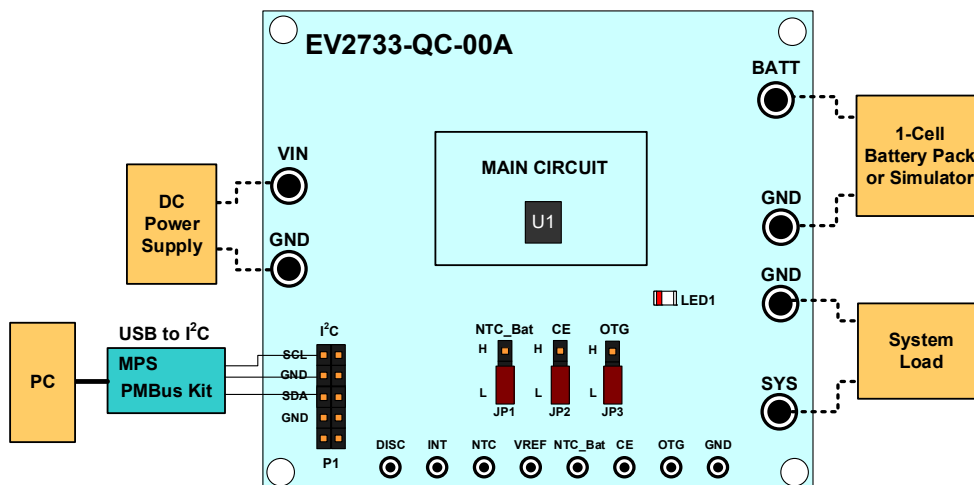

Figure 2: Test Set-Up for the MP2733

- Turn on the computer, and launch the MP2733 evaluation software. Figure 3 shows the GUI software's main window.

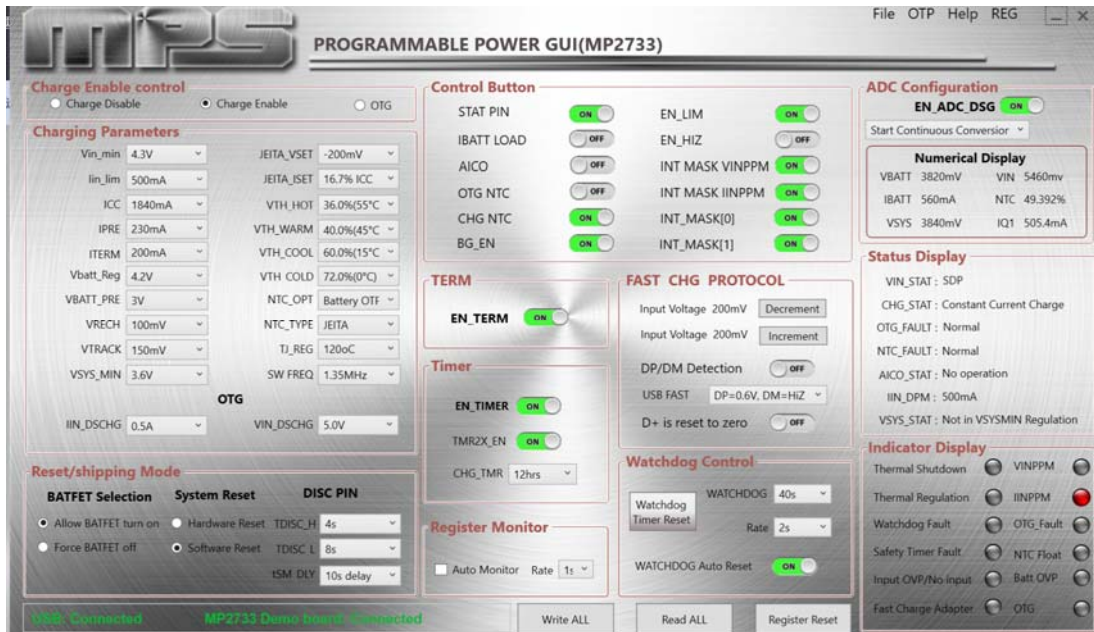

Figure 3: MP2733 Evaluation Software

Procedure

- Ensure that all the connections are successful (the EVKT-USBI2C-02 and the EV2733-QC-00A are connected). Successful connections are indicated in green on the lower-left side of the window (see Figure 3). The program is ready to be run once all of the connections are successful.
- Select the MP2733's operation mode (see Figure 4).

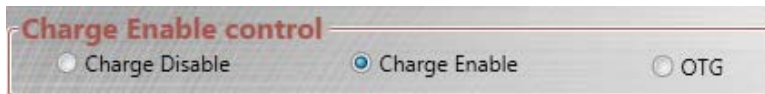

Figure 4: MP2733 GUI Operation Mode

- Set the charging parameters (see Figure 5).

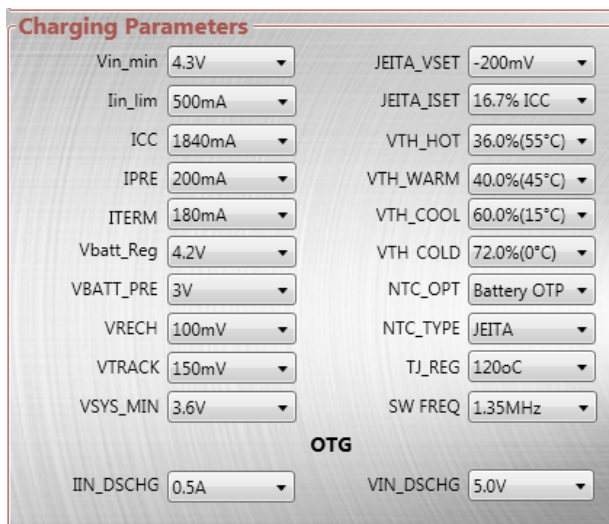

Figure 5: MP2733 GUI Charging Parameters Display

- Set the input voltage regulation threshold (see Figure 6). The input voltage regulation threshold ranges between 3.7V and 15.2V, and the default value is 4.3V. Set this value according to the V_{BATT_REG} setting. For example, if V_{BATT_REG} is set to 4.35V, it is recommended to set the input voltage regulation threshold to 4.6V or higher.

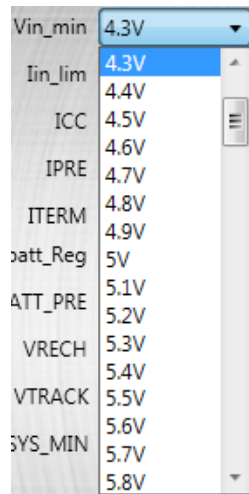

Figure 6: Input Voltage Regulation Threshold Setting

- Set the input current limit (see Figure 7). The input current limit ranges between 100mA and 3250mA, and the default value is 500mA. Set it to the value that meets the input source capacity.

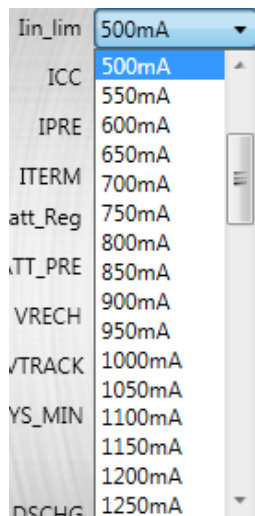

Figure 7: Input Current Limit Setting

The input current limit can be set below the input source’s maximum current rating. When the input current reaches its set limit, the charge current is reduced to keep the input current constant at this limit. This ensures that the system is powered safely.

- Set the constant charge current (see Figure 8). The constant charge current ranges between 320mA and 4520mA, and the default charge current is set to 1840mA. The real charge current is limited to the input current limit setting.

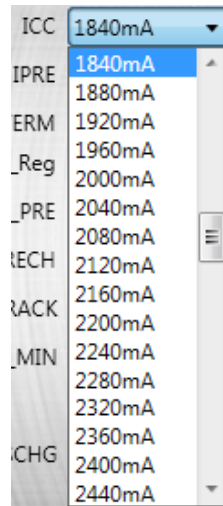

Figure 8: Constant Charge Current Setting

- Set the pre-charge current (see Figure 9). The pre-charge current ranges between 150mA and 750mA, and the default value is 230mA.

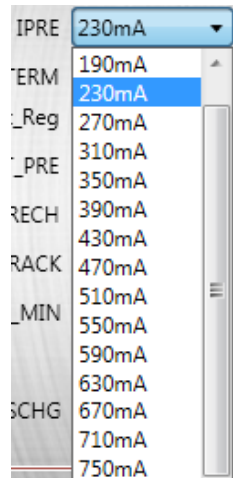

Figure 9: Pre-Charge Current Setting

- Set the terminal charge current (see Figure 10). The terminal charge current ranges between 100mA and 700mA, and the default value is 180mA.

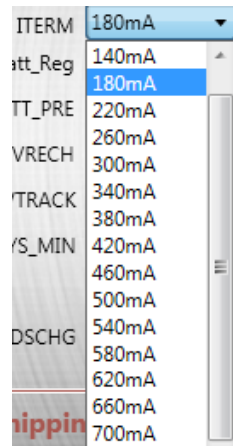

Figure 10: Terminal Charge Current Setting

9. Set the charge-full voltage (see Figure 11). The charge-full voltage ranges between 3.4V and 4.67V, and the default value is 4.2V.

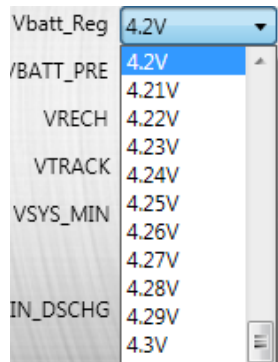

Figure 11: Charge-Full Voltage Setting

10. Set the pre-charge to constant current charge threshold voltage (see Figure 12). This threshold can be set to 2.8V or 3.0V, and the default value is 3.0V.

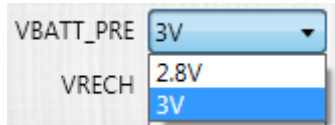

Figure 12: V_{BATT_PRE} Setting

11. Set the battery auto-recharge voltage to V_{BATT_REG} minus the value selected in the drop-down menu (see Figure 13). This voltage can be set to 100mV or 200mV, and the default value is 100mV.

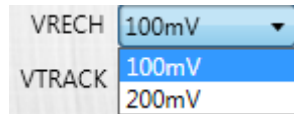

Figure 13: V_{RECH} Setting

12. Set the voltage variation between the SYS regulation voltage and V_{SYN_MIN} (see Figure 14). The variation can be set to 100mV or 150mV, and the default value is 150mV.

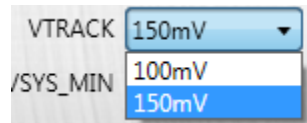

Figure 14: V_{TRACK} Setting

13. Set the V_{SYN_MIN} voltage threshold (see Figure 15). This threshold ranges between 3V and 3.75V, and the default value is 3.6V.

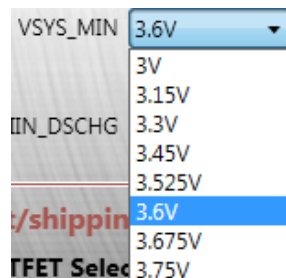

Figure 15: V_{SYN_MIN} Setting

14. Set the switching frequency (see Figure 16). The switching frequency can be set to 1.35MHz or 1MHz, and the default value is 1.35MHz.

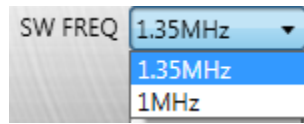

Figure 16: Switching Frequency Setting

15. Set the NTC functions according to the selected NTC thermistor and requirements (see Figure 17). If this function is not included during the evaluation, leave the default settings.

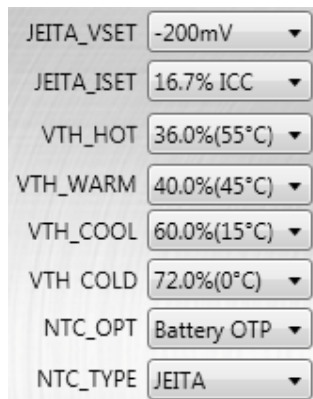

Figure 17: NTC Functions Settings

16. Set the thermal regulation threshold (see Figure 18). The thermal regulation threshold ranges between 60°C and 120°C, and the default value is 120°C.

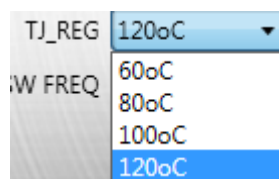

Figure 18: Thermal Regulation Threshold Setting

17. Select the termination setting (see Figure 19).



Figure 19: Termination Setting

18. Set the charge timer (see Figure 20). The charge timer ranges between 5hrs and 20hrs, and the default value is 12hrs.

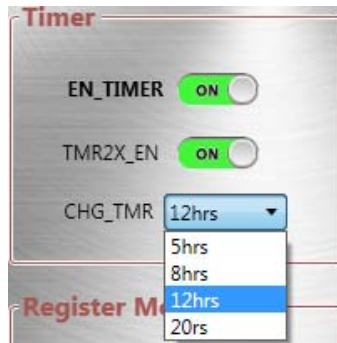

Figure 20: Charge Timer Setting

The integrated charge timer provides backup protection to prevent a damaged battery from being charged after a certain time. The MP2733 can disable the timer function by switching off the EN_TIMER button (see Figure 20).

Boost Function

When the MP2733 is configured to USB On-the-Go (OTG) mode, the output voltage and current limit can be controlled via the I²C.

1. Turn off and remove the power source connected from VIN to PGND.
2. If the constant voltage load connected from BATT+ to GND is not a four-quadrant supply (source current), remove the load and use the power source that was disconnected in step 1. Then establish a connection between the positive port of the BATT output (BATT+) and PGND, with a 4.0V voltage limit and 3.5A current limit.
3. Apply a resistor ($R = 3\Omega$ to 10Ω for 5W or greater) across the positive VIN terminal (VIN+) and negative PGND terminal (PGND-).
4. Pull JP3 high, and select OTG from the Charge Enable Control menu (see Figure 21).

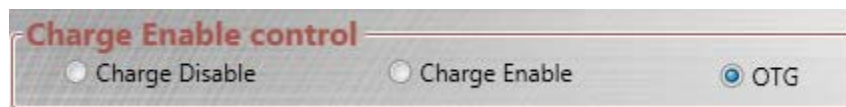

Figure 21: Charge Enable Control Menu

5. Set the OTG output voltage regulation threshold (see Figure 22). It ranges between 4.8V and 5.5V, and the default value is 5.0V.

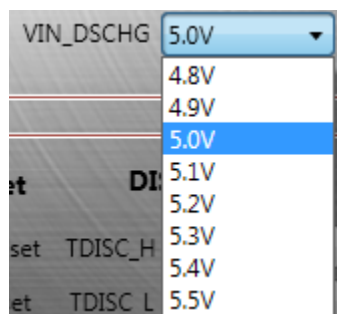

Figure 22: OTG Output Voltage Regulation Setting

- Set the OTG current limit (see Figure 23). The OTG current limit ranges between 0.5A and 3.0A, and the default value is 0.5A.

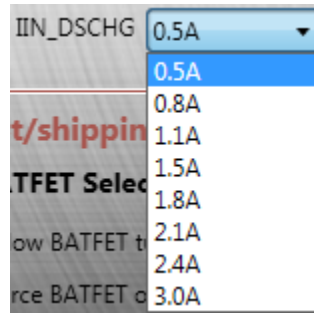

Figure 23: OTG Current Limit Setting

Other Controls

The MP2733 evaluation software offers other controls as well. These controls include:

- Shipping mode control (see Figure 24).

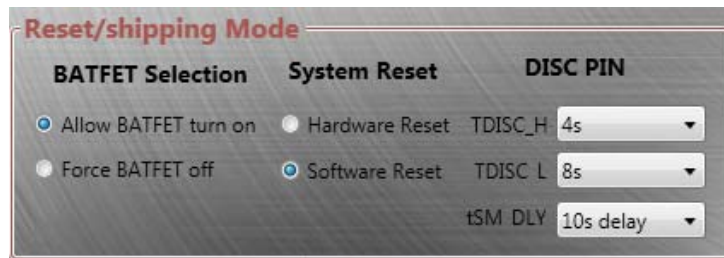

Figure 24: Shipping Mode Control

- Watchdog control (see Figure 25).



Figure 25: Watchdog Control

- A register auto-monitor function (see Figure 26).



Figure 26: Register Auto-Monitor

- ADC configuration (see Figure 27).

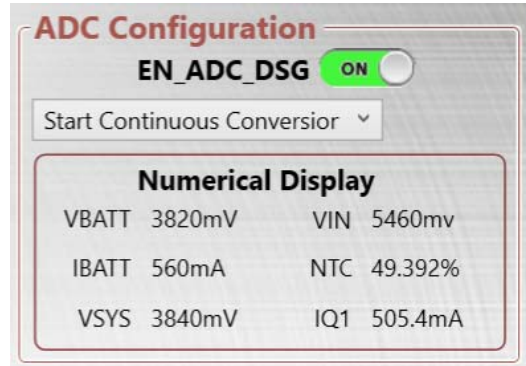

Figure 27: ADC Configuration

The ADC function in discharge mode can be enabled by the EN_ADC_DSG bit. VBATT can be monitored by the ADC during discharge mode.

- Fast charge protocol control (see Figure 28).

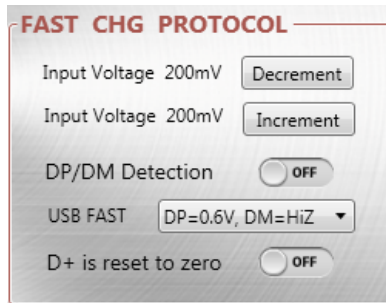

Figure 28: Fast Charge Protocol Setting

- MP2733 operation status monitoring (see Figure 29).

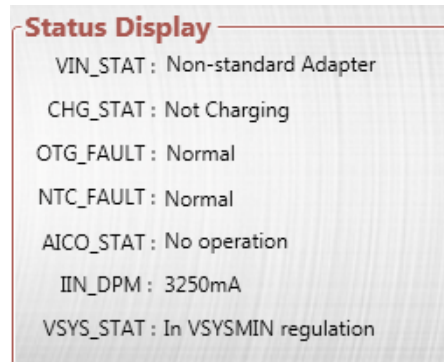

Figure 29: Operation Status Display

- MP2733 fault monitoring (see Figure 30)

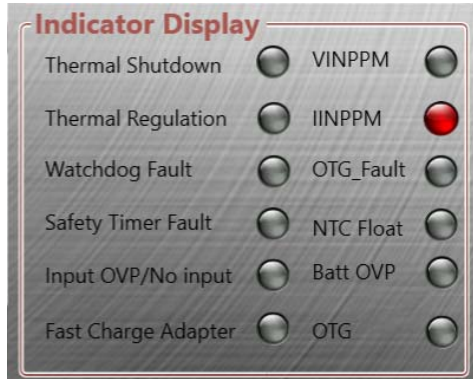

Figure 30: Fault Monitoring Indicator Display

- Additional control settings (see Figure 31)

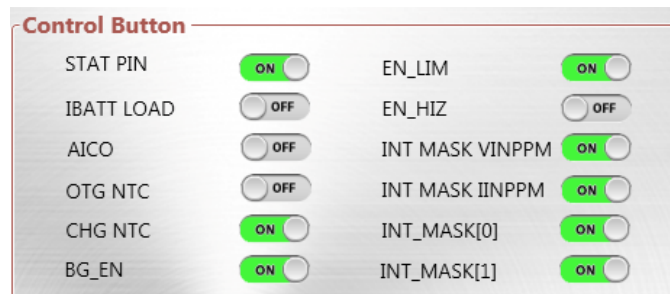
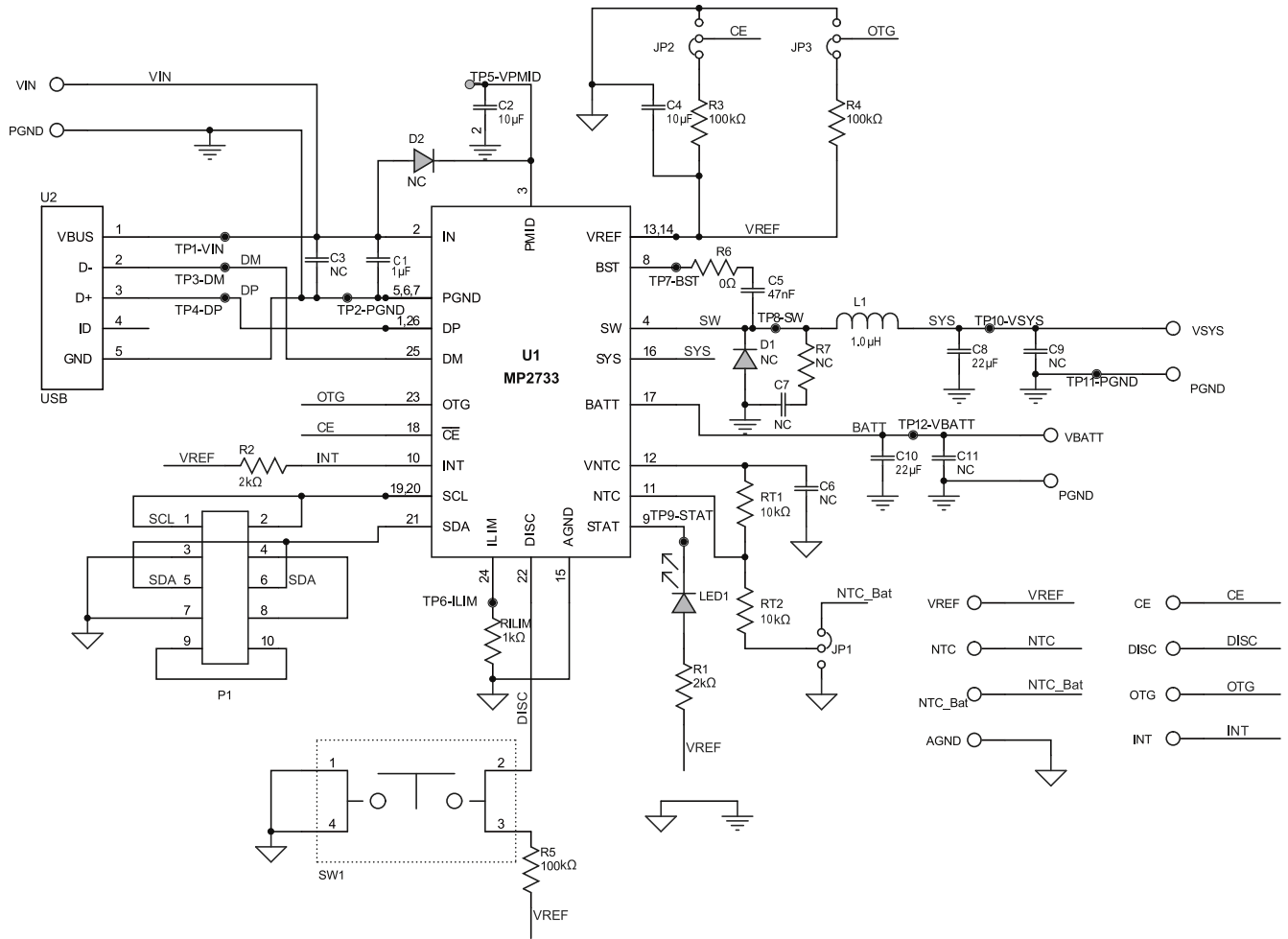

Figure 31: Additional Controls

EVALUATION BOARD SCHEMATIC (1)

Figure 32: Evaluation Board Schematic
Note:

- 1) For the SYS capacitor (C8), it is recommended to use a 22µF X5R/X7R capacitor with a 1206 package for better performance.

EV2733-QC-00A BILL OF MATERIALS

Qty	Ref	Value	Description	Package	Manufacturer	Manufacturer P/N
1	C1	1 μ F	Ceramic capacitor, 25V, X7R, 0603	0603	Murata	GRM188R71E105KA12D
1	C2	10 μ F	Ceramic capacitor, 50V, X5R, 1206	1206	Murata	GRM31CR61H106KA12L
1	C3	NC	Ceramic capacitor, 50V, X5R, 1206	1206	Murata	
1	C4	10 μ F	Ceramic capacitor, 16V, X5R, 0603	0603	Murata	GRM188R61C106KAALD
1	C5	47nF	Ceramic capacitor, 50V, X7R, 0603	0603	Murata	GRM188R71H473KA61D
2	C6, C7	NC	Ceramic capacitor, 16V, X5R, 0603	0603	Murata	
2	C8, C10	22 μ F	Ceramic capacitor, 16V, X5R, 1206	1206	Murata	GRM31CR61C226KE15L
2	C9, C11	NC	Ceramic capacitor, 16V, X5R, 0805	0805	Murata	
2	D1, D2	NC	Diode, 50V, 3A	SMA	HQ	
1	L1	1.0 μ H	Inductor, 1.0 μ H	SMD	Cyntec	HTEP32251B-1R0MIR-89
1	LED1	Red	Red LED	0805	Bright LED	BL-HUF35A-TRB
2	R1, R2	2k Ω	Film resistor, 1%	0603	Yageo	RC0603FR-072KL
3	R3, R4, R5	100k Ω	Film resistor, 5%	0603	Yageo	RC0603JR-07100KL
1	R6	0 Ω	Film resistor, 1%	0603	Yageo	RC0603FR-070RL
1	R7	NC	Film resistor, 1%	0603	Yageo	
1	RILIM	1k Ω	Film resistor, 1%	0603	Yageo	RC0603FR-071KL
2	RT1, RT2	10k Ω	Film resistor, 1%	0603	Yageo	RC0603FR-0710KL
1	SW1	SM	Button	SM, 4mmx10mm x1.5mm	Any	
3	JP1, JP2, JP3	DIP	2.54mm connector	DIP	Any	
1	P1	DIP	Header, 5-pin, dual row	DIP	Any	

EV2733-QC-00A BILL OF MATERIALS (continued)

Qty	Ref	Value	Description	Package	Manufacturer	Manufacturer P/N
8	DISC, VREF, AGND, OTG, CE, INT, NTC, NTC BATT	DIP	2.54mm connector	DIP	Any	
12	DM, DP, VBATT, GND, VSYS, BST, STAT, SW VPMID, GND, VIN, ILIM	DIP	Test point (yellow)	DIP	Any	
6	VIN, PGND, VBATT, PGND, PGND, VSYS	DIP	2mm port	DIP	Any	
1	U1	MP2733	Switch-mode battery charger	QFN-26 (3.5mmx3.5mm)	MPS	MP2733GQC-0000
1	U2	Micro- USB	Micro-USB	DIP	Würth	629105150521

EVB TEST RESULTS

$V_{IN} = 5.0V$, $V_{BATT} = \text{full range}$, I²C-controlled, $I_{CC} = 0A \text{ to } 3A$, $I_{IN_LIM} = 3250mA$, $V_{IN_MIN} = 4.3V$, $T_A = 25^\circ C$, $L1 = 1.0\mu H$, $C_{BATT} = 22\mu F$, $C_{SYS} = 22\mu F$, $C_{IN} = 1\mu F$, $C_{PMID} = 10\mu F$, unless otherwise noted.

Battery Charge Curve

$V_{IN} = 5V$, $V_{BATT_REG} = 4.2V$, $I_{SYS} = 0A$

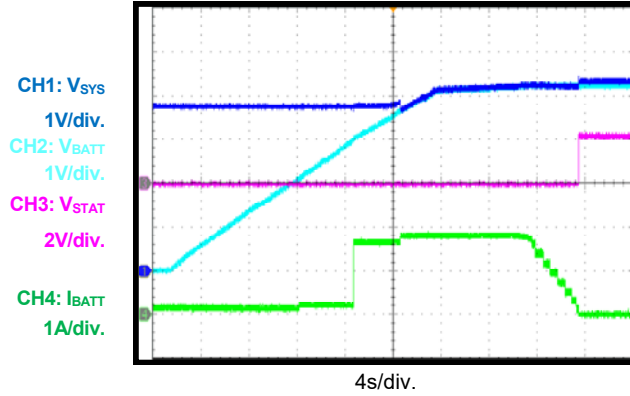

Auto-Recharge

$V_{IN} = 5V$, $V_{BATT_REG} = 4.2V$, $I_{SYS} = 0A$

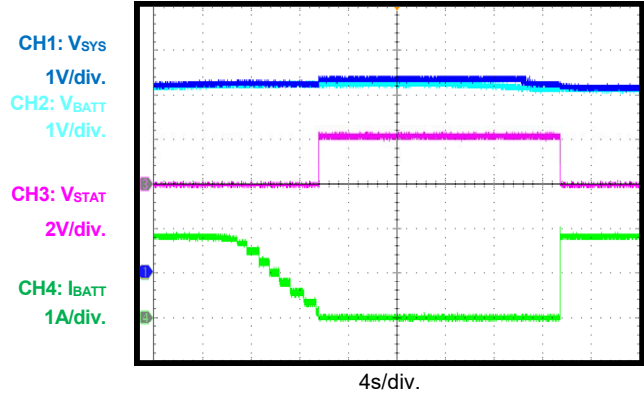

Trickle Charge

$V_{IN} = 5V$, $V_{BATT} = 1.0V$, $I_{SYS} = 500mA$

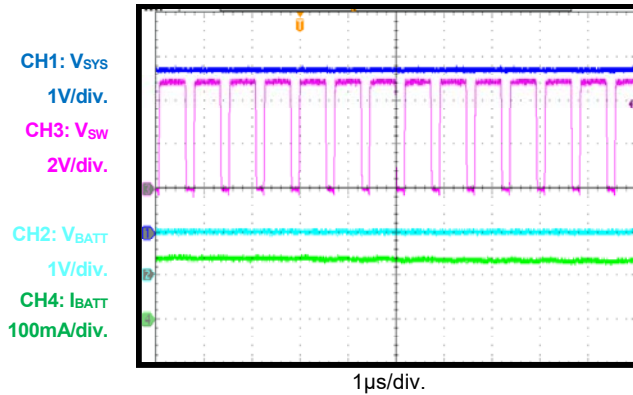

Pre-Charge

$V_{IN} = 5V$, $V_{BATT} = 2.5V$, $I_{PRE} = 680mA$

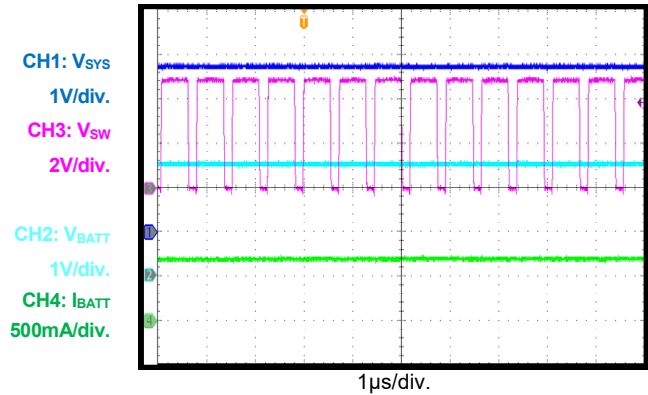

Constant Current Charge

$V_{IN} = 5V$, $V_{BATT} = 3.3V$, $I_{CC} = 1840mA$

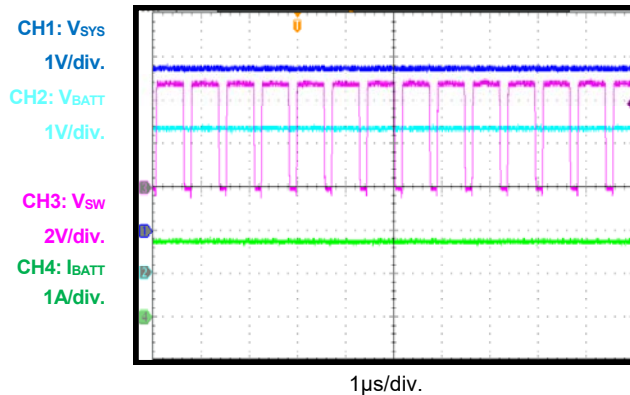

Constant Current Charge

$V_{IN} = 5V$, $V_{BATT} = 3.8V$, $I_{CC} = 1840mA$

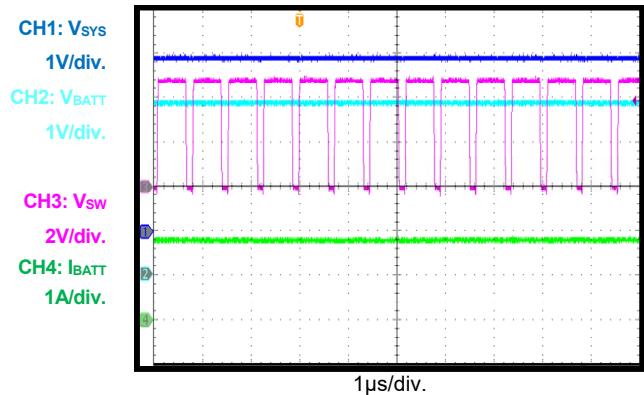

EVB TEST RESULTS (continued)

V_{IN} = 5.0V, V_{BATT} = full range, I²C-controlled, I_{CC} = 0A to 3A, I_{IN_LIM} = 3250mA, V_{IN_MIN} = 4.3V, T_A = 25°C, L₁ = 1.0μH, C_{BATT} = 22μF, C_{SYS} = 22μF, C_{IN} = 1μF, C_{PMID} = 10μF, unless otherwise noted.

Constant Current Charge

V_{IN} = 9V, V_{BATT} = 3.3V, I_{CC} = 1840mA

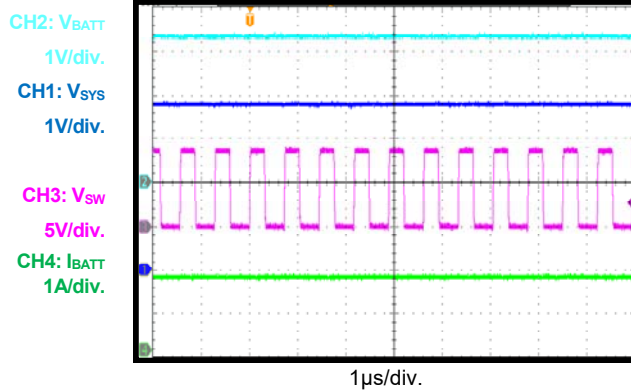

Constant Current Charge

V_{IN} = 9V, V_{BATT} = 3.8V, I_{CC} = 1840mA

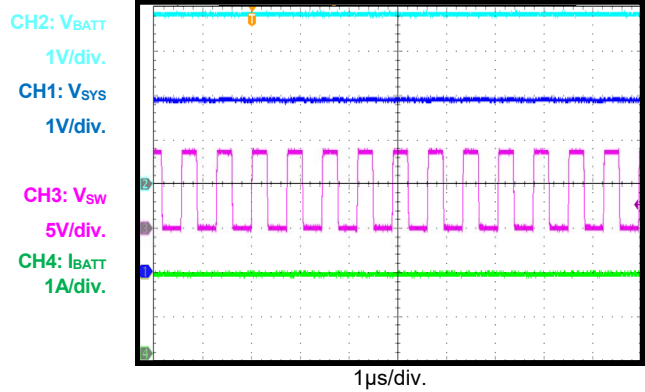

Constant Current Charge

V_{IN} = 12V, V_{BATT} = 3.3V, I_{CC} = 1840mA

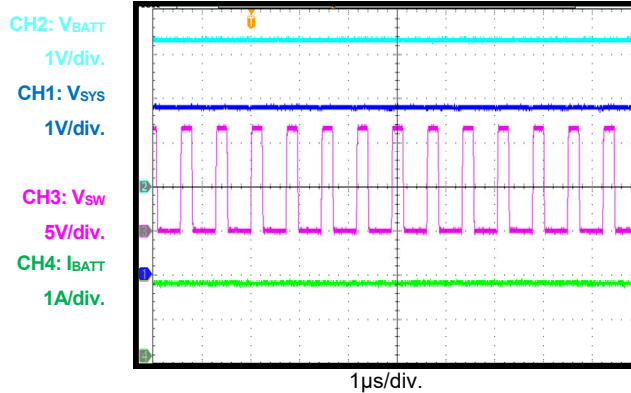

Constant Current Charge

V_{IN} = 12V, V_{BATT} = 3.8V, I_{CC} = 1840mA

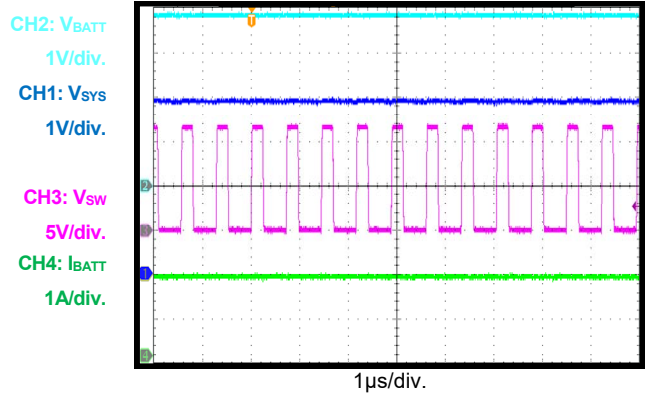

Constant Current Charge

V_{IN} = 16V, V_{BATT} = 3.3V, I_{CC} = 1840mA

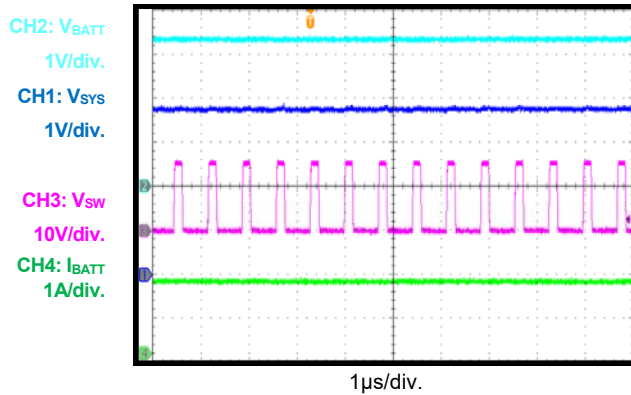

Constant Current Charge

V_{IN} = 16V, V_{BATT} = 3.8V, I_{CC} = 1840mA

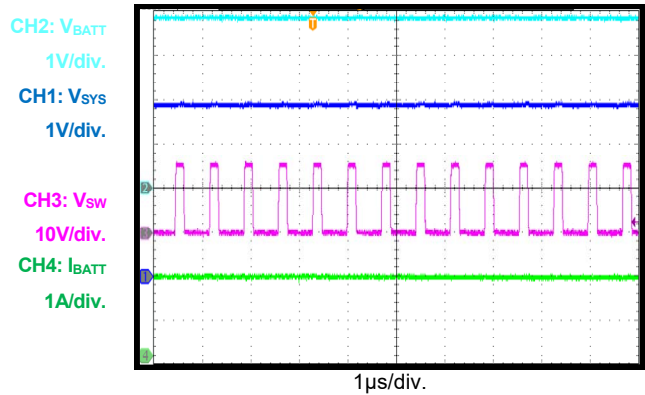

EVB TEST RESULTS (continued)

$V_{IN} = 5.0V$, $V_{BATT} = \text{full range}$, I²C-controlled, $I_{CC} = 0A$ to $3A$, $I_{IN_LIM} = 3250mA$, $V_{IN_MIN} = 4.3V$, $T_A = 25^\circ C$, $L1 = 1.0\mu H$, $C_{BATT} = 22\mu F$, $C_{SYS} = 22\mu F$, $C_{IN} = 1\mu F$, $C_{PMID} = 10\mu F$, unless otherwise noted.

Battery Supplement Mode

$V_{IN} = 5V$, $V_{BATT} = 3.8V$, $I_{SYS} = 4.5A$

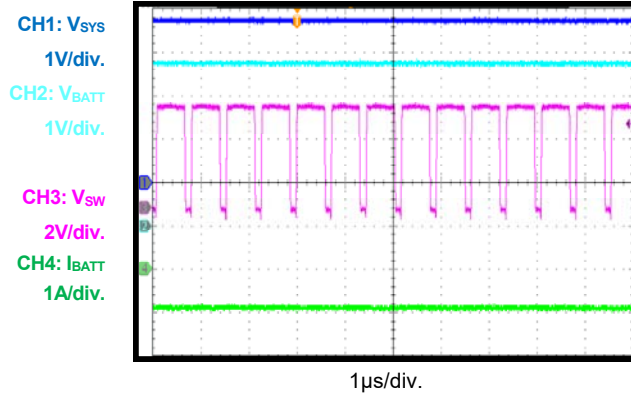
Constant Voltage Charge

$V_{IN} = 5V$, $V_{BATT} = 4.19V$, $I_{SYS} = 0A$

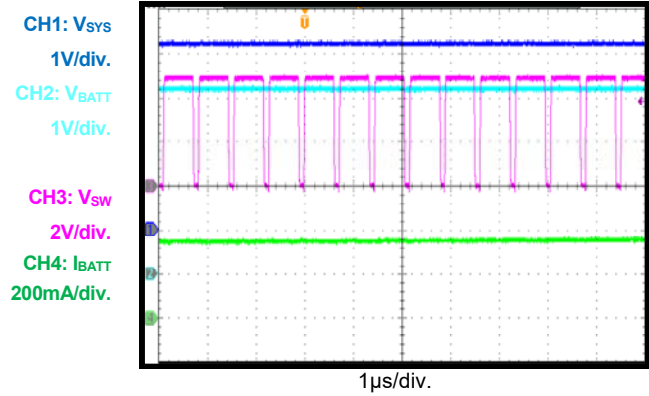
Input Current Limit

$V_{IN} = 5V$, $V_{BATT} = 3.8V$, $I_{IN_LIM} = 1800mA$

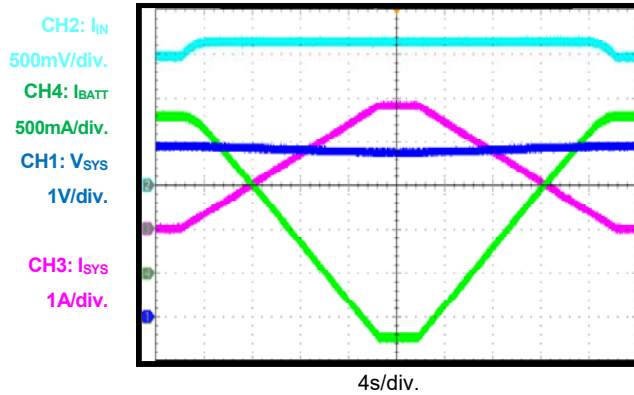
Input Voltage Limit

$V_{IN} = 5V$ (2A), $V_{BATT} = 3.3V$, $V_{IN_MIN} = 4.6V$

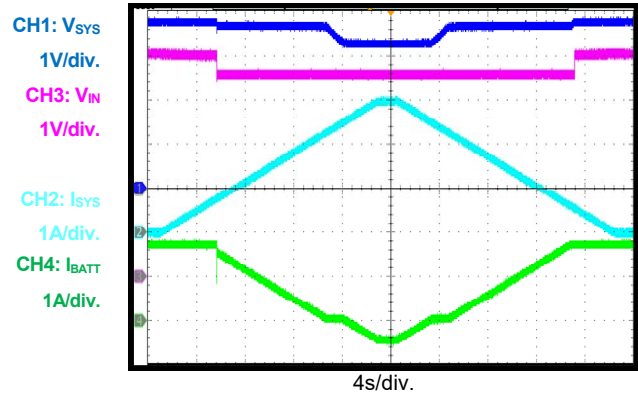
Start-Up/Shutdown Waveform

$V_{IN} = 5V$, $I_{IN_LIM} = 500mA$, $V_{BATT} = 3.8V$, $I_{SYS} = 2.5A$

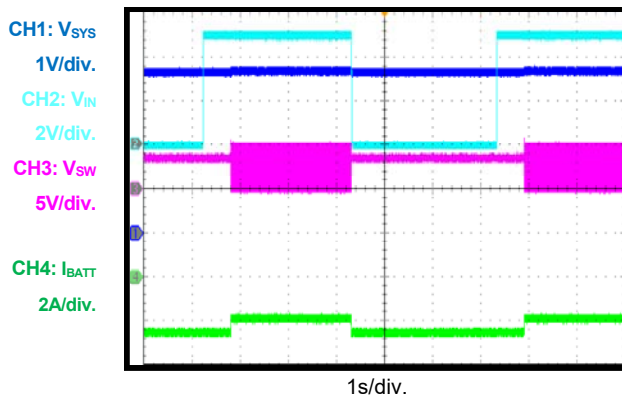
Start-Up/Shutdown Waveform

$V_{IN} = 5V$, $I_{IN_LIM} = 500mA$, $V_{BATT} = 3.3V$, $I_{SYS} = 0.5A$

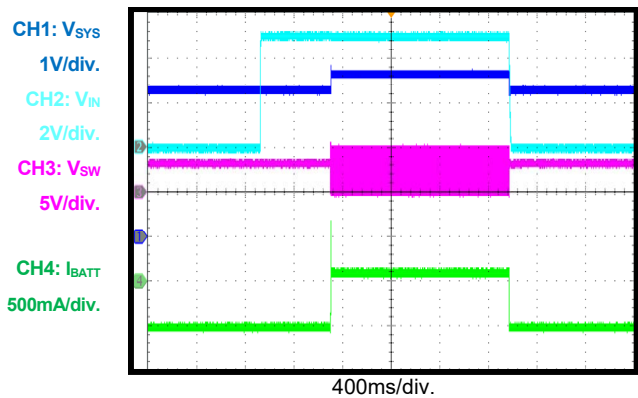

EVB TEST RESULTS (continued)

$V_{IN} = 5.0V$, $V_{BATT} = \text{full range}$, I²C-controlled, $I_{CC} = 0A$ to $3A$, $I_{IN_LIM} = 3250mA$, $V_{IN_MIN} = 4.3V$, $T_A = 25^\circ C$, $L1 = 1.0\mu H$, $C_{BATT} = 22\mu F$, $C_{SYS} = 22\mu F$, $C_{IN} = 1\mu F$, $C_{PMID} = 10\mu F$, unless otherwise noted.

Suspend Mode On/Off

$V_{IN} = 5V$, $I_{IN_LIM} = 500mA$, $V_{BATT} = 4.0V$,
 $I_{SYS} = 0.5A$

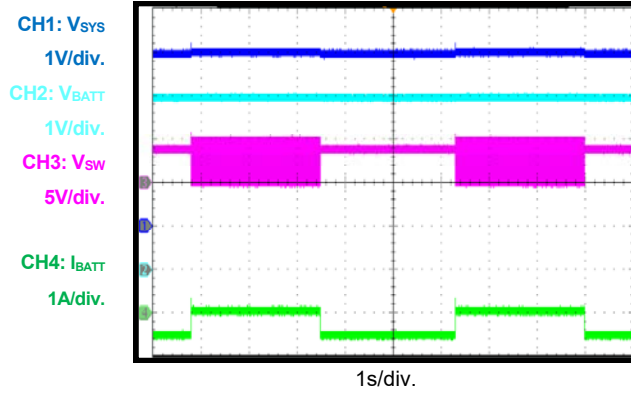
Charge On/Off

$V_{IN} = 5V$, $V_{BATT} = 4.0V$, $I_{SYS} = 0A$

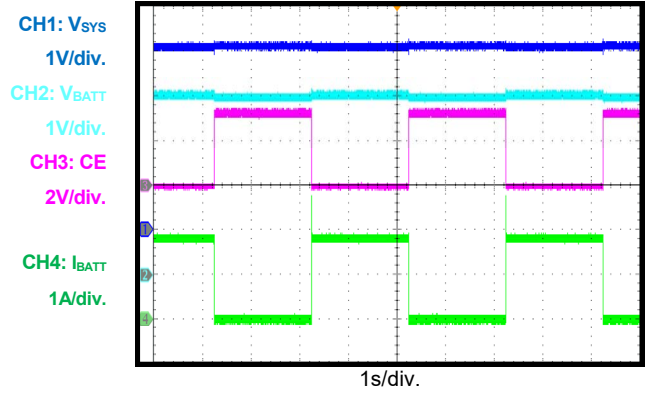
BATFET On/Off

$V_{IN} = 5V$, $V_{BATT} = 4.0V$, $I_{SYS} = 4A$

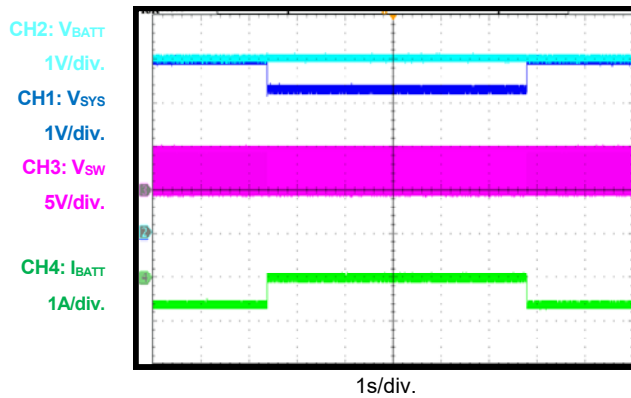
VIN Hot Insertion/Removal

$V_{IN} = 5V$, $I_{IN_LIM} = 500mA$, $V_{BATT} = 3.8V$

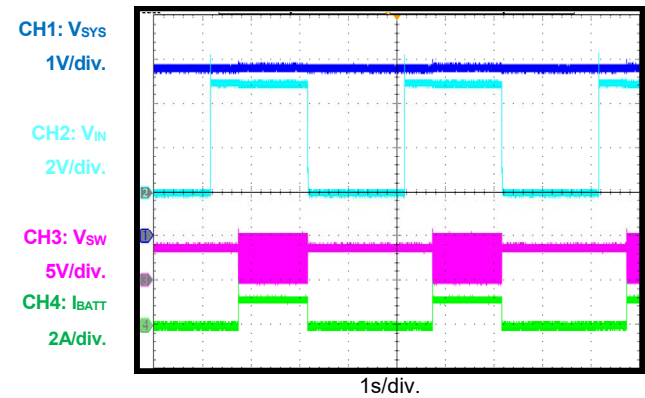
SYS Load Transient

$V_{IN} = 5V$, $V_{BATT} = 3.3V$, charge disable,
 $I_{SYS} = 1A$ to $3A$

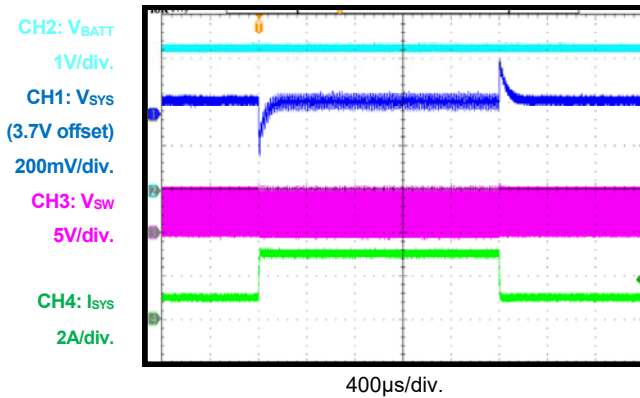
VIN OVP Test

$V_{IN} = 5V$ to $17V$, $V_{BATT} = 3.8V$, $I_{SYS} = 1A$

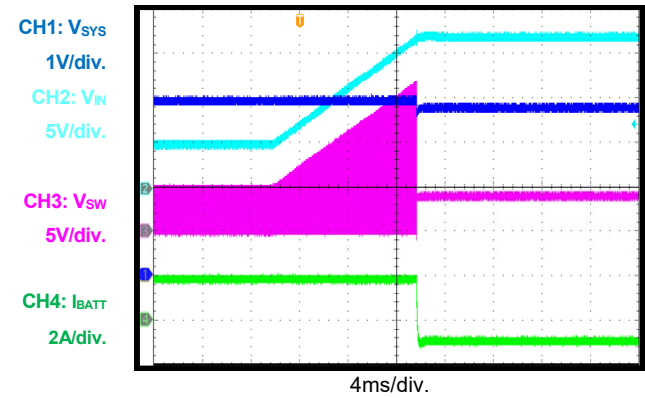

EVB TEST RESULTS (continued)

$V_{IN} = 5.0V$, $V_{BATT} = \text{full range}$, I²C-controlled, $I_{CC} = 0A \text{ to } 3A$, $I_{IN_LIM} = 3250mA$, $V_{IN_MIN} = 4.3V$, $T_A = 25^\circ C$, $L1 = 1.0\mu H$, $C_{BATT} = 22\mu F$, $C_{SYS} = 22\mu F$, $C_{IN} = 1\mu F$, $C_{PMID} = 10\mu F$, unless otherwise noted.

System Reset Mode

$V_{IN} = \text{float}$, $V_{BATT} = 3.8V$, $I_{SYS} = 2A$

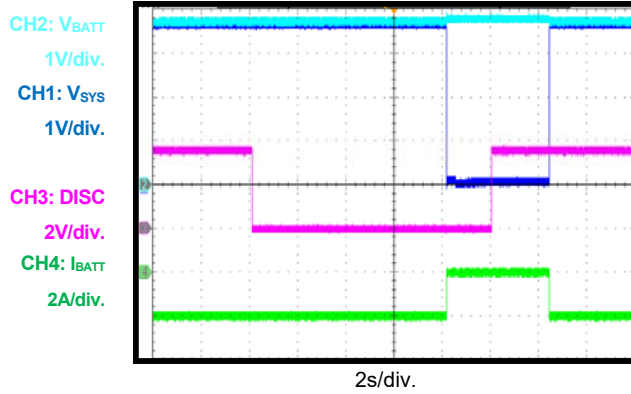
Battery Discharge Current

$V_{IN} = \text{float}$, $V_{BATT} = 4.0V$, $I_{SYS} = \text{up to } 10A$

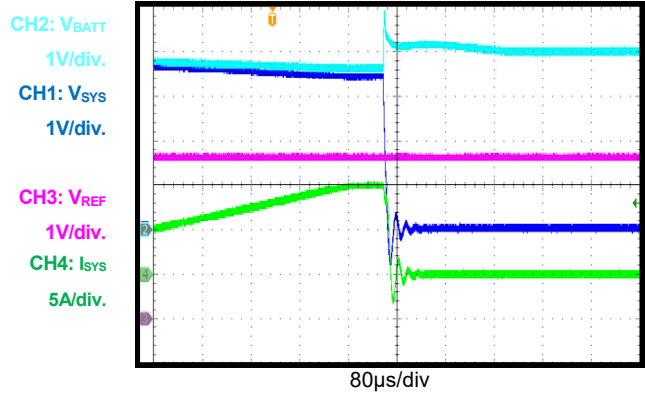
OTG Mode On

$V_{IN} = \text{float}$, OTG mode, $V_{BATT} = 3.3V$, $I_{IN_DSCHG} = 0.5A$, $I_{OTG} = 0.5A$

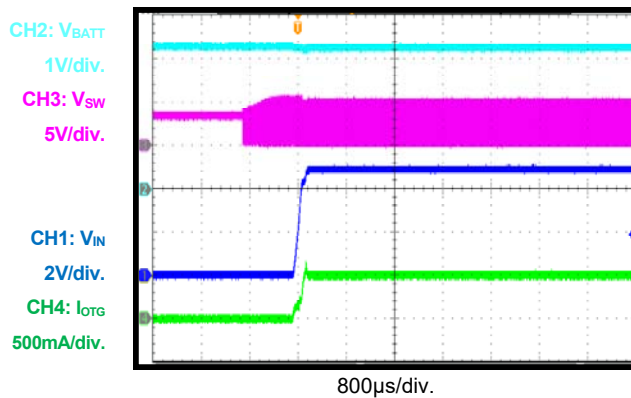
OTG Steady State Operation

$V_{IN} = \text{float}$, OTG mode, $V_{BATT} = 4.0V$, $I_{IN_DSCHG} = 3.0A$, $I_{OTG} = 1.5A$

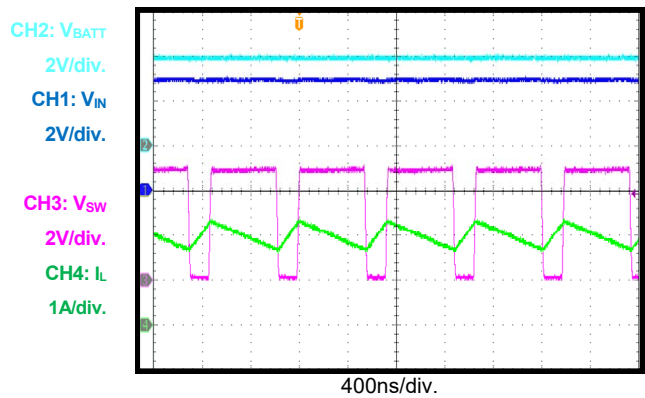
OTG Voltage Regulation

$V_{IN} = \text{float}$, OTG mode, $V_{BATT} = 4.0V$, $I_{IN_DSCHG} = 1.5A$, $I_{OTG} = 0A \text{ to } 1.5A$

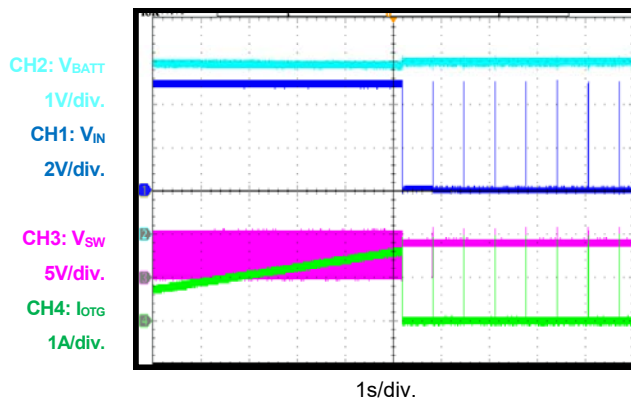
NTC JEITA Operation

$V_{IN} = 5V$, $V_{BATT} = 4.07V$, $I_{SYS} = 0A$, JEITA_ISET = 50%, JEITA_VSET = -100mV

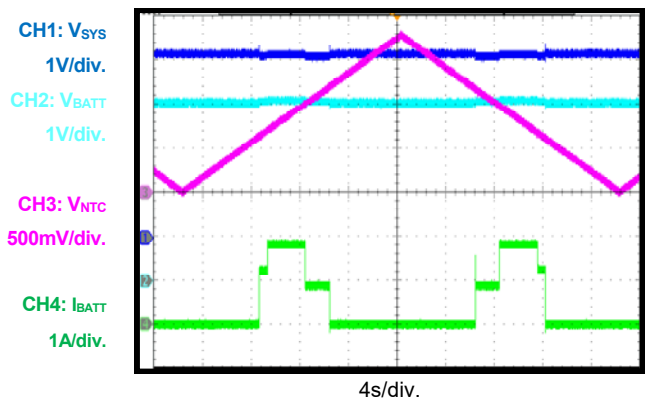

PCB LAYOUT

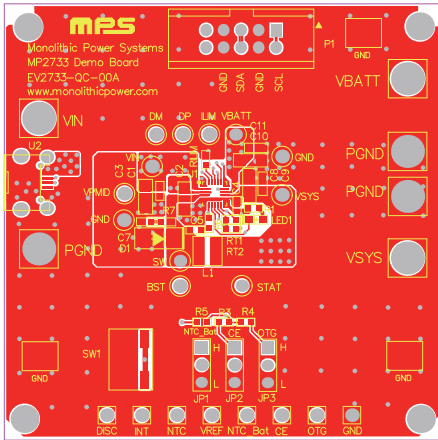

Figure 33: Top Layer

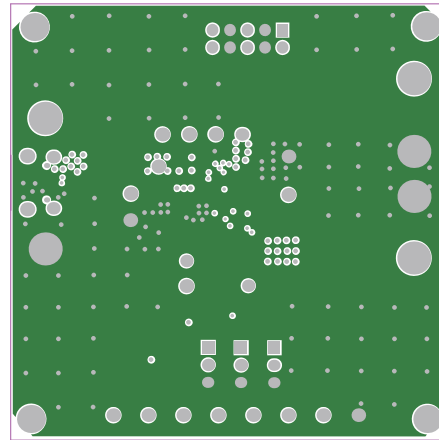

Figure 34: Mid-Layer 1

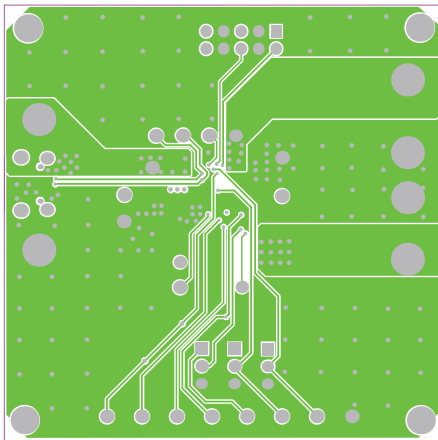

Figure 35: Mid-Layer 2

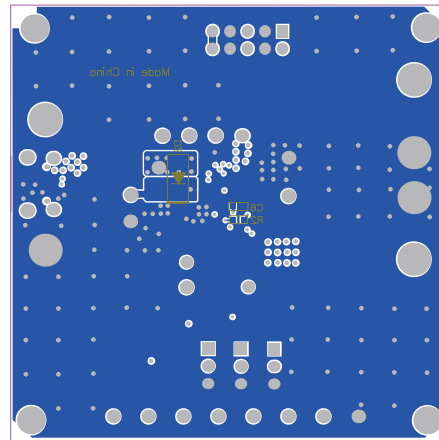

Figure 36: Bottom Layer