



# EV3370-N-00A

## Single-String, 38V V<sub>OUT</sub>, Boost LED Driver with Current Source Evaluation Board

### DESCRIPTION

The EV3370-N-00A is an evaluation board for the MP3370, a fixed-frequency boost converter with current source. It is ideal for medium to high current boost LED driver applications.

The MP3370 regulates the output voltage up to 38V to drive more LEDs with an integrated 100mΩ/50V low-side MOSFET. The peak current mode regulation and external compensation components allow the MP3370 control loop to be optimized across a wide range of input voltage, output voltage, and load current applications. The internal soft start, cycle-by-cycle current limiting, and input under-voltage lockout features prevent overstressing or damage to sensitive external circuitry during start-up or if there is a fault.

The MP3370 supports PWM dimming and analog dimming for flexible dimming applications. It is available in a thermally enhanced SOIC-8EP package with an exposed pad.

### FEATURES

- 3.5V to 36V Input Range
- More than 3A Peak Current Limit
- Internal 100mΩ 50V Power Switch
- Analog/PWM Dimming
- High Efficiency
- Under-Voltage Lockout Protection
- LED Open/Short Protection
- Inductor/Diode Short Protection
- 43.5V Over-Voltage Protection
- Soft-Start Operation
- Thermal Shutdown
- Available in an SOIC-8EP Package

### APPLICATIONS

- Medium-Sized LCD Backlighting
- General Lighting

All MPS parts are lead-free, halogen free, and adhere to the RoHS directive. For MPS green status, please visit MPS website under Quality Assurance. "MPS", the MPS logo, and "Simple, Easy Solutions" are Registered Trademarks of Monolithic Power Systems, Inc. or its subsidiaries.

### ELECTRICAL SPECIFICATIONS

Parameter	Symbol	Value	Units
Input voltage	V <sub>IN</sub>	12	V
Output voltage	V <sub>LED</sub>	<38	V
LED current/string	I <sub>LED</sub>	300	mA

### EV3370-N-00A EVALUATION BOARD

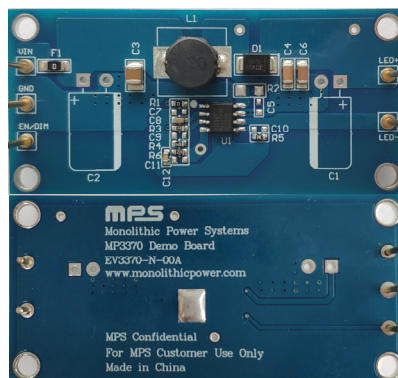

(LxWxH) 6.35cmx3.0cm

Board Number	MPS IC Number
EV3370-R-00A	MP3370GN



## QUICK START GUIDE

1. Provide a 3.5V to 36V voltage source between the VIN terminal and GND on the board.
2. Connect the LED string terminals to:
  - a. Positive (+): LED+
  - b. Negative (-): LED-
3. Drive the EN/DIM pin high to enable the MP3370. If EN/DIM remains low for 20ms, the IC is disabled.
4. Add a dimming signal on the EN/DIM pin.
  - a. For PWM dimming, supply a PWM signal with a frequency below 1kHz.
  - b. For analog dimming, supply a PWM signal with a frequency above 5kHz.

### EVALUATION BOARD SCHEMATIC

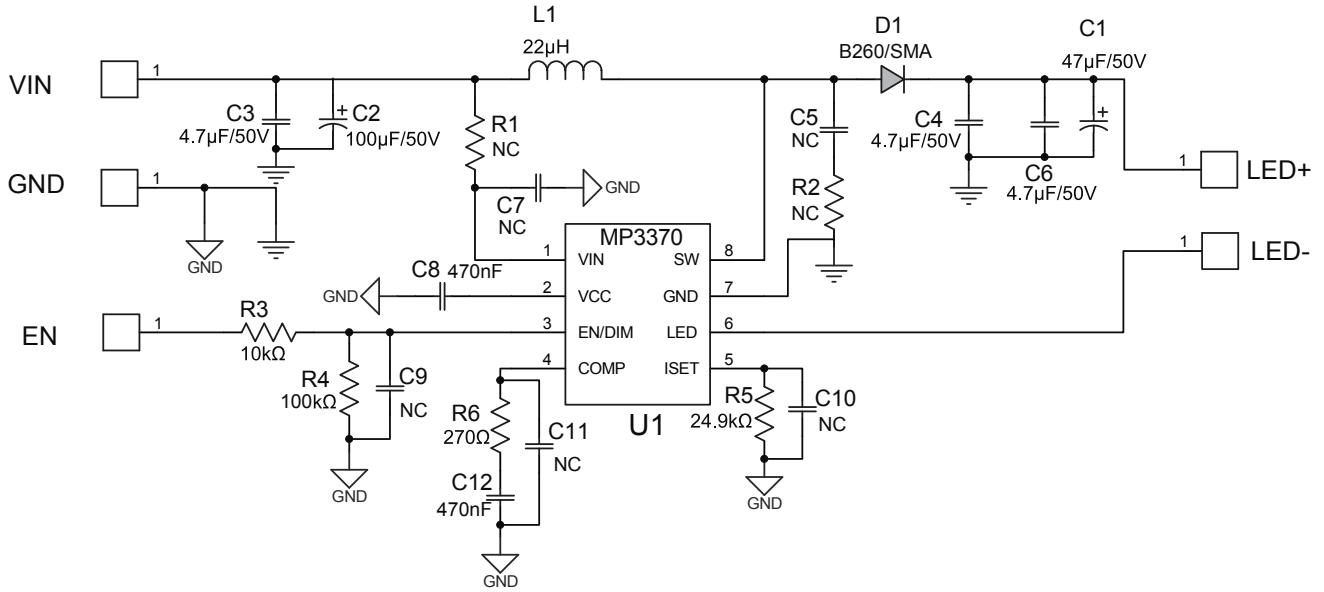

Figure 1: Evaluation Board Schematic

**EV3370-N-00A BILL OF MATERIALS**

Qty	Ref	Value	Description	Package	Manufacturer	Manufacturer P/N
1	C1	NC	Electrolytic capacitor, 22 $\mu$ F/50V	DIP		
1	C2	NC	Electrolytic capacitor, 100 $\mu$ F/50V	DIP		
1	C3	4.7 $\mu$ F/ 50V	Ceramic capacitor, 50V, X7R, 1210	CAP/1210	Murata	GRM32ER71H475KA88L
2	C4, C6	4.7 $\mu$ F/ 50V	Ceramic capacitor, 50V, X7R, 1206	CAP/1206	TDK	C3216X7R1H475K
5	C5, C7, C9, C10, C11	NC		CAP/0603		
1	C8,C12	470nF/ 10V	Ceramic capacitor, 16V, X7R	CAP/0603	TDK	C1608X7R1C474K
1	D1		Schottky diode, 60V, 2A	DIODES/ SMB	Diodes	B260
1	F1	0 $\Omega$	Film resistor, 1%	RES/1206	Yageo	RC1206FR-070RL
1	L1	22 $\mu$ H	Inductor, 22 $\mu$ H, 77.6m, I <sub>SAT</sub> = 3A	D104C-919AS -220M	Toko	D104C-919AS-220M
1	R1	0 $\Omega$	Film resistor, 1%	RES/0603	Yageo	RC0603FR-070RL
1	R2	NC	Film resistor, 1%	RES/1206		
1	R3	10k $\Omega$	Film resistor, 1%	RES/0603	Yageo	RC0603FR-0710KL
1	R4	100k $\Omega$	Film resistor, 5%	RES/0603	Yageo	RC0603JR-07100KL
1	R5	24.9k $\Omega$	Film resistor, 1%	RES/0603	Yageo	RC0603FR-0724K9L
1	R6	270 $\Omega$	Film resistor, 1%	RES/0603	Yageo	RC0603FR-07270RL
1	U1	MP3370	Boost converter with current source	SOIC8-EP	MPS	MP3370GN

